



OPERATION MANUAL

PRODUCT NAME : Parallel Type Air Gripper

MODEL : MHSL Series

- Read this operation manual carefully to understand before installation and operation.
- Pay extra attention on the clause concerning the safety.
- Keep this operation manual available whenever necessary.

SMC CORPORATION

Contents

1. Product specifications

1 - 1. Specifications

2. Usage and handling

2 - 1. Precautions on design

2 - 2. Selection

2 - 3. Mounting

2 - 4. Supply air

2 - 5. Piping

2 - 6. Operating environment

2 - 7. Lubrication

3. Maintenance

3 - 1. Precautions

3 - 2. Exploded view



3 - 3. Packing replacement procedure

3 - 4. Structural drawing / Parts list, Packing list

Notes to users

Safety Instructions

These safety instructions are intended to prevent a hazardous situation and/or equipment damage. These instructions indicate the level of potential hazard by label of “Caution” , “Warning” , or “Danger” . To ensure safety, be sure to observe ISO 4414 ^{*1)} , JIS B 8370 ^{*2)} and other safety practices.

- | |
|--|
|  Caution : Operator error could result in injury or equipment damage. |
|  Warning : Operator error could result in serious injury or loss of life. |
|  Danger : In extreme conditions, there is a possible result of serious injury or loss of life. |

(*1) ISO 4414 : Pneumatic fluid power—Recommendations for the application of equipment to transmission and control systems.

(*2) JIS B 8370 : Pneumatic systems axiom.



WARNING

- ① The compatibility of pneumatic equipment is the responsibility of the person who designs the pneumatic system or decides its specifications.

Since the products specified here are used in various operating conditions, their compatibility for the specific pneumatic system must be based on specifications or after analysis and/or tests to meet your specific requirements.

- ② Only trained personnel should operate pneumatically operated machinery and equipment.

compressed air can be dangerous if an operator is unfamiliar it. Assembly, handling or repair of pneumatic systems should be performed by trained and experienced operators.

- ③ Do not service machinery/equipment or attempt to remove components until safety is confirmed.

1. Inspection and maintenance of machinery/equipment should only be performed after confirmation of safe locked-out control positions.
2. When equipment is to be removed, confirm the safety process as mentioned above. Cut the supply pressure for this equipment and exhaust all residual compressed air in the system.
3. Before machinery/equipment is restarted, take measures to prevent shooting-out of cylinder piston rod, etc.(Bleed air into the system gradually to create back-pressure.)

- ④ Contact SMC if the product is to be used in any of the following conditions:

1. Conditions and environments beyond the given specifications, or if product is used outdoors.
2. Installation on equipment in conjunction with atomic energy, railway, air navigation, vehicles, medical equipment, food and beverages, recreation equipment, emergency stop circuits, press applications, or safety equipment.
3. An application which has the possibility of having negative effects on people, property, or animals, requiring special safety analysis.

1. Product Specifications

1-1. Specifications

MHSL3 Series												
Model	MHSL3 ·16D	MHSL3 ·20D	MHSL3 ·25D	MHSL3 ·32D	MHSL3 ·40D	MHSL3 ·50D	MHSL3 ·63D	MHSL3 ·80D	MHSL3 ·100D	MHSL3 ·125D		
Cylinder bore (mm)	16	20	25	32	40	50	63	80	100	125		
Fluid	Air											
Operating pressure MPa	0.2~0.6			0.1~0.6								
Ambient and fluid temperature °C	-10~60											
Repeatability mm	±0.01											
Maximum operating frequency c.p.m	120			60				30				
Lubrication	Not required											
Action	Double acting											
Effective gripping force *1) N	External gripping force		14	25	42	74	118	187	335	500	750	1,270
	Internal gripping force		16	28	47	82	130	204	359	525	780	1,320
Opening/Closing stroke(diameter) mm	10	10	12	16	20	28	32	40	48	64		
Weight g	80	135	180	370	550	930	1,550	2,850	5,500	11,300		

*1) Values for $\phi 16$ to $\phi 25$ are with gripping point $L=20$ mm, for $\phi 32$ to $\phi 63$ with gripping point $L=30$ mm and for $\phi 80$ to $\phi 125$ with gripping point $L=50$ mm.

Supply air pressure is 0.5 MPa.

2. Usage and Handling

2-1 Precautions on Design

⚠ Warning

1. Provide a protective cover to minimize the risk of personal injury due to accidental contact with moving parts of the gripper or with moving work pieces.
2. Take measures to prevent an unexpected dropping of work pieces due to a loss of air pressure caused by service interruption or air supply failure.
3. Consult SMC when this product is used for applications other than carrying of works, such as positioning and clamping.

2-2 Selection

⚠ Warning

1. Keep the gripping point within the limits of the specified gripping range.
With gripping a point out of the range, excessive moment load may act on the sliding part of fingers, which may shorten life span of the product. Refer to its catalog for further details.

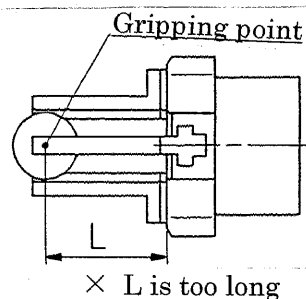
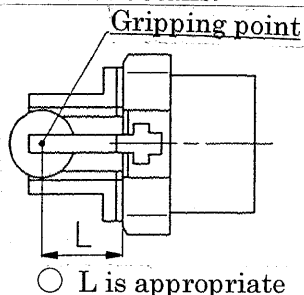

2. Design attachments to be the lightest and shortest possible.

- ① Long and heavy attachments increase the inertial force when opening and closing fingers. This may cause unsteady movement of the fingers and have an adverse effect on life span of the product.
- ② Even with the gripping point within the limits of the range, make the attachments as light and short as possible. Refer to catalog for details.

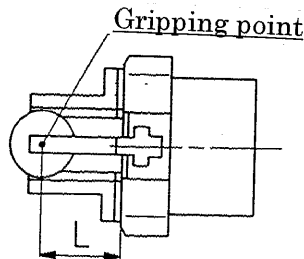

- ③ Select a larger size gripper or use multiple grippers for handling long and large work pieces.
3. Provide run off space in the attachments when handling small or thin work pieces.
If run off space is not provided, gripping becomes unstable, and it may fail to grip or the position may slip, etc.

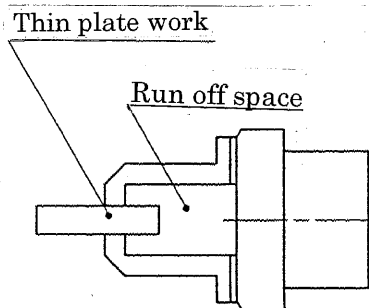

4. Select model which has sufficient gripping force for the work piece weight.
Incorrect selection may lead to dropping of work pieces, etc. Refer to the catalog for effective gripping force of each series and work piece weight.
5. Avoid applications where excessive external force or impact acts.
Such applications may cause failure. Consult SMC If necessary.
6. Select a model having a sufficient finger opening width for a work piece.
<In case of insufficient width>
 - ① Gripping becomes unstable due to variations in opening width or work piece diameter.
 - ② Detection failure occurs when using an auto-switch. by referring to the information on auto-switch hysteresis of each series, secure a sufficient stroke for hysteresis. When Water Resistance Improved Two Color Auto-Switch is used, stroke may be limited depending on the lamp colors setting at detecting.

2-3 Mounting

Warning

1. Do not drop or dent the gripper when mounting it.
Even a slight deformation will cause inaccuracy or malfunction.
2. Tighten screws within the specified torque range when mounting attachments.
Tightening with a higher torque than specified one may cause malfunction, while tightening with a lower torque may allow slipping of the gripping position or dropping of work pieces.

Mounting of Attachments on Fingers

Use tightening torque in the table below and mount attachments by inserting bolts in female mounting thread of fingers.

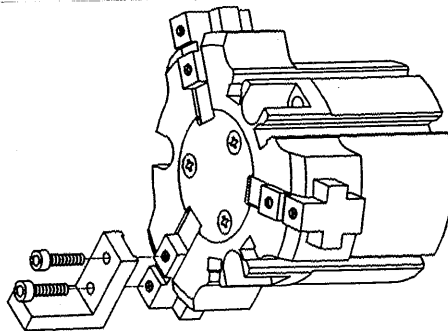

Model	Bolt	Max. tightening torque N · m	Max. screw-in depth (mm)
MHSL3-16D	M3×0.5	0.59	5
MHSL3-20D			6
MHSL3-25D			6
MHSL3-32D	M4×0.7	1.4	8
MHSL3-40D			8
MHSL3-50D	M5×0.8	2.8	10
MHSL3-63D			10
MHSL3-80D	M6×1	4.8	12
MHSL3-100D	M8×1.25	12	16
MHSL3-125D	M10×1.5	24	20

3. Tighten Air Gripper with a proper torque within the specified range.
Tightening with a higher torque than the specified one may cause malfunction, while tightening with a lower torque may allow slipping of the gripping position or dropping of work pieces. Refer to pages 7 for tightening torque.

Mounting of Air Gripper
Tapped holes

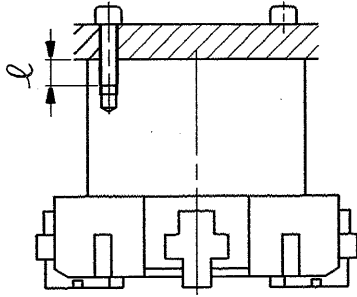

Holes on the end face of the body can be used for positioning

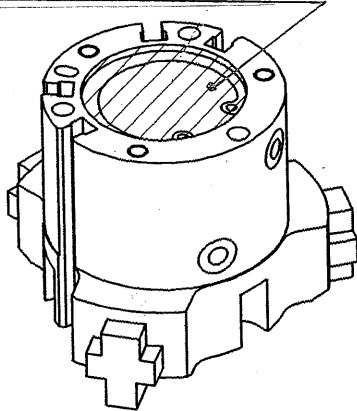

Through holes

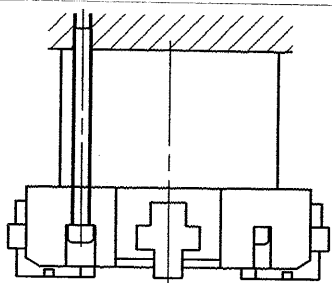

Model	Bolt	Max. tightening torque N · m	Max. screw-in depth (l mm)
MHSL3-16D	M3 × 0.5	0.88	6
20D	M3 × 0.5	0.88	6
25D	M4 × 0.7	1.6	6
32D	M4 × 0.7	1.6	6
40D	M5 × 0.8	4.3	10
50D	M5 × 0.8	4.3	10
63D	M6 × 1	7.3	12
80D	M6 × 1	7.3	12
100D	M8 × 1.25	18	16
125D	M10 × 1.5	36	20

Model	Bolt	Max. tightening torque N · m
MHSL3-16D	M3 × 0.5	0.88
20D	M3 × 0.5	0.88
25D	M4 × 0.7	2.1
32D	M4 × 0.7	2.1
40D	M5 × 0.8	4.3
50D	M5 × 0.8	4.3
63D	M6 × 1	7.3
80D	M6 × 1	7.3
100D	M8 × 1.25	18
125D	M10 × 1.5	36

⚠ Caution

1. Avoid twisting of the fingers when mounting the attachments.

Any deformation of fingers may cause malfunction and loss of accuracy.

2. Avoid external force on the fingers.

Fingers may be damaged by continual lateral or impact loads.

Provide clearance to prevent the work piece or attachments from striking against any objects at the stroke end.

① Stroke end with fingers open

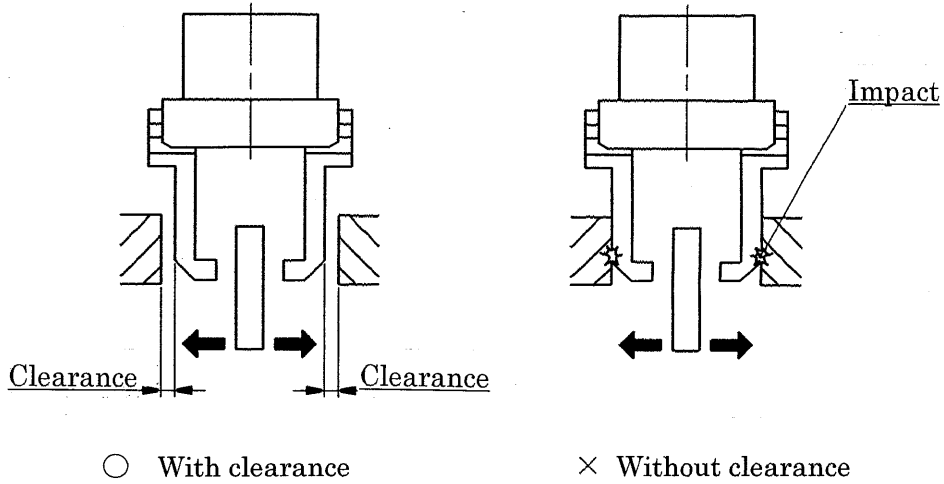

② Stroke end with air gripper moving

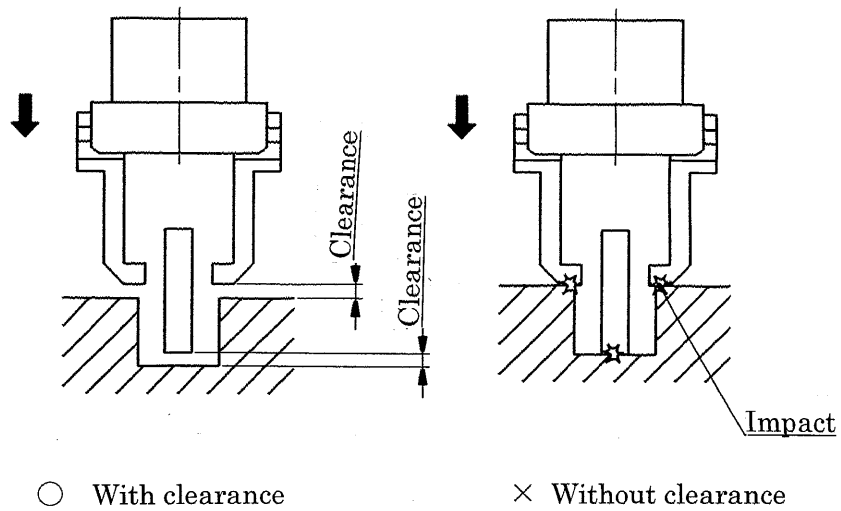

3. Perform thorough alignment and assure that excessive force is not applied to the fingers during the work piece gripping operation.

Particularly when performing a trial run, operation should be done manually or with low cylinder pressure and speed, while confirming that there is no impact or other unsafe conditions.

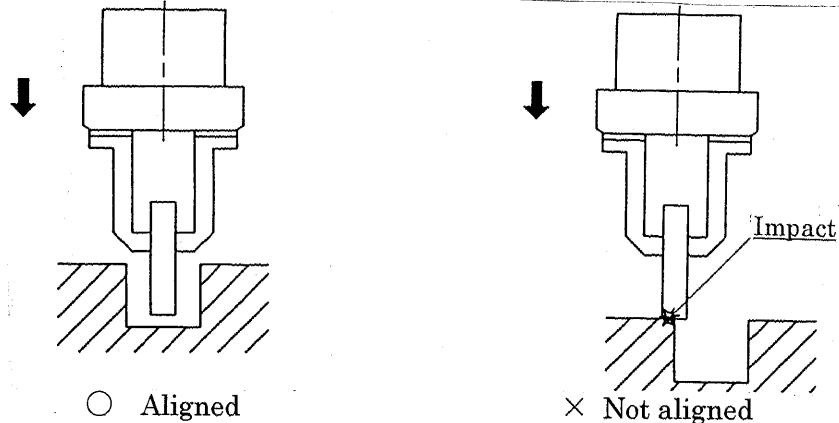

4. Use a device such as a speed controller for adjustment so that the finger Closing speed and the pushrod extension/retraction are no faster than necessary. If the finger closing speed and the push rod extension/retraction speed are greater than necessary, the impact force acting on the fingers and other parts will increase, causing a danger of reduced work piece gripping repeatability and an adverse effect on service life.

Applicable speed controllers

Air gripper direct

Coupling type: AS1200, M3, M5
AS2200-01, etc.

In-line type: AS1000 Series
AS1001F, AS2051F, etc.

2-4. Supply Air

Warning

1. Use clean air

If the compressed air supply includes chemicals, synthetic materials (including organic solvents), salinity, corrosive gas, etc., it can lead to damage or malfunction.

Caution

1. Install an air filter.

Install an air filter at the upper stream side of the valve. Nominal filtration rating should be $5\ \mu\text{m}$ or less.

2. Install an air dryer, after cooler, drain catch, etc.

Air including excessive condensate may cause malfunction of valve and other pneumatic equipment. To prevent this, install an air dryer, after cooler, drain catch, etc.

3. Fluid and ambient temperature should be within the specifications.

When it is below 5°C , water in the circuit will freeze, which will cause breakage of packing and malfunction. Therefore, take measures to prevent freezing.

Refer to "Air Cleaning Equipment" catalog for compressed air quality.

2-5 Piping

Caution

1.Preparation before piping.

Before piping is connected, it should be thoroughly blown out with air (flushing) or washed to remove cutting chips, cutting oil and other debris from inside the pipe.

2.Wrapping of pipe tape.

When screwing together pipes and fittings,etc., be certain that cutting chips from the pipe threads and sealing material do not get inside the piping.

Also, when pipe tape is used, leave 1.5 to 2 thread ridges exposed at the end of the pipe.

2-6 Operating Environment

Warning

1.Do not operate in locations having an atmosphere of corrosive gases, chemicals sea vapor, water or water vapor,or where contact with any of thses may occur.

2.Provide shading in locations which receive direct sunlight.

3.Do not use in locations where vibration or impact occurs.

4.Do not use in locations near heat sources or where radiated heat will be received.

5.Attach a cover or other protection in locations where there will be exposure to excessive amounts of dust or cutting oil.

6.Contact SMC before using in an environment where adverse effects appear particularly likely.

2-7 Lubrication

Caution

1.The air gripper is lubricated at the factory, and can be used without any further lubrication.

In the event that lubrication will be applied, use Class 1 turbine oil(without additives) ISO VG32.Moreover, once lubrication is applied, it must be continued.

If lubrication is later stopped, malfunction can occur due to loss of the original lubricant.

3. Maintenance

3-1 Precautions

Warning

1.Do not allow people to enter or place objects, etc. into the carrying path of the air gripper.

this can cause injury or accidents,etc.

2.Do not put hands, etc. between the air gripper fingers or attachments.

This can cause injury or accidents, etc.

3.When removing the air gripper, first confirm that no work pieces are being held and then release the compressed air before removing the air gripper.

If a work piece is still being held , there is a danger of it being dropped.

3-3 Packing Replacement Procedure

1. Remove C-shape snap ring with a specified tool, then remove cap.

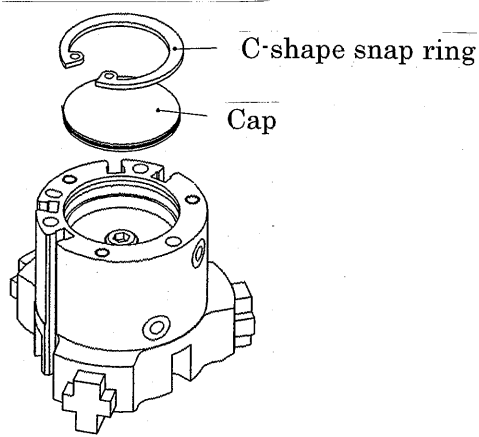

2. Remove piston bolt.

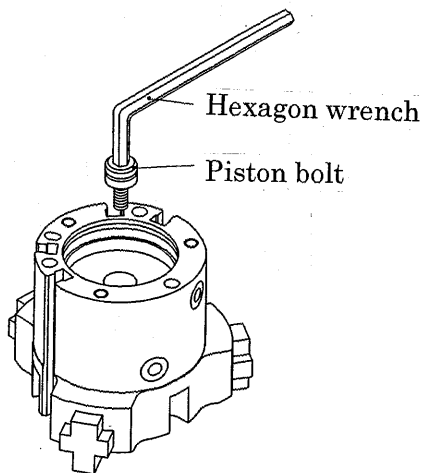

Cylinder bore	Bolt	Across flat
φ 16	M3×0.5	2.5
φ 20	M3×0.5	2.5
φ 25	M4×0.7	3
φ 32	M5×0.8	4
φ 40	M5×0.8	4
φ 50	M6×1	5
φ 63	M8×1.25	6
φ 80	M10×1.5	8
φ 100	M12×1.75	10
φ 125	M14×2	12

3. Remove piston with a specified tool, and replace packing.

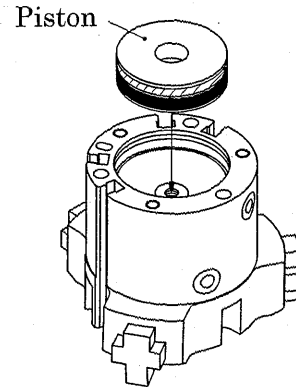

4. Unscrew cross recessed countersunk head screws and remove end plate.

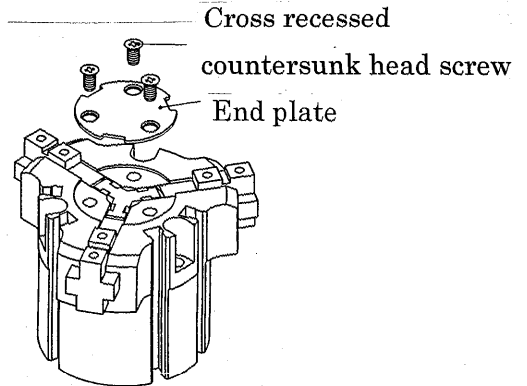

5. Open fingers and remove cam, and then replace packing.

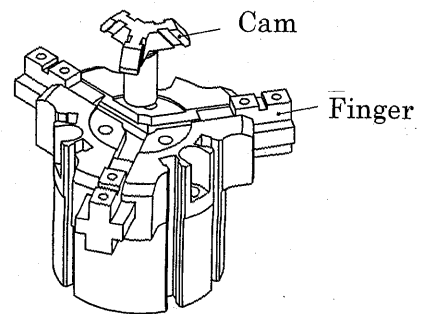

- Assemble the parts in the reverse order of disassembling.
- Dedicated grease is available. Consult SMC.

3-2 Exploded view

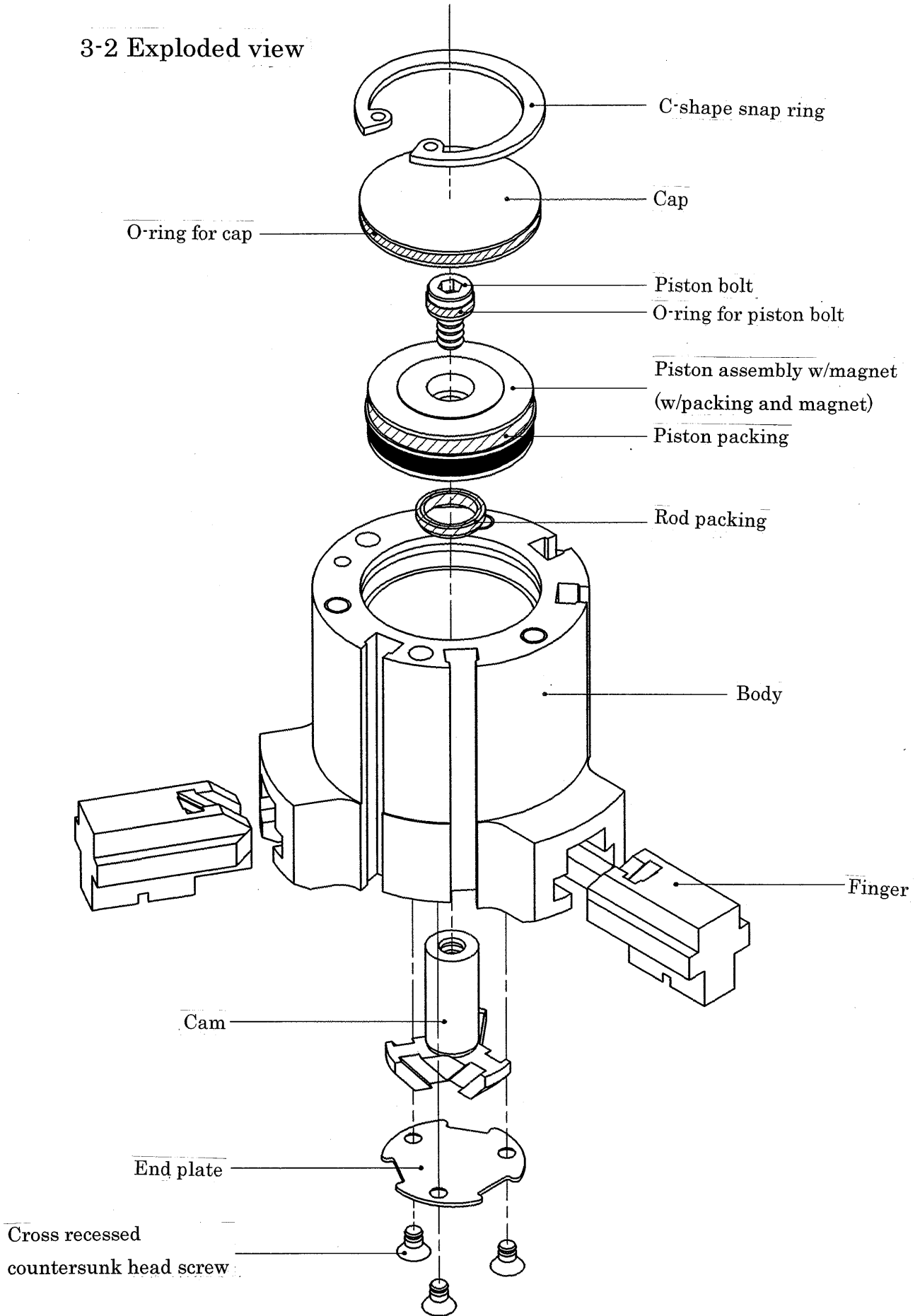

3-4 Structural drawing / Packing List

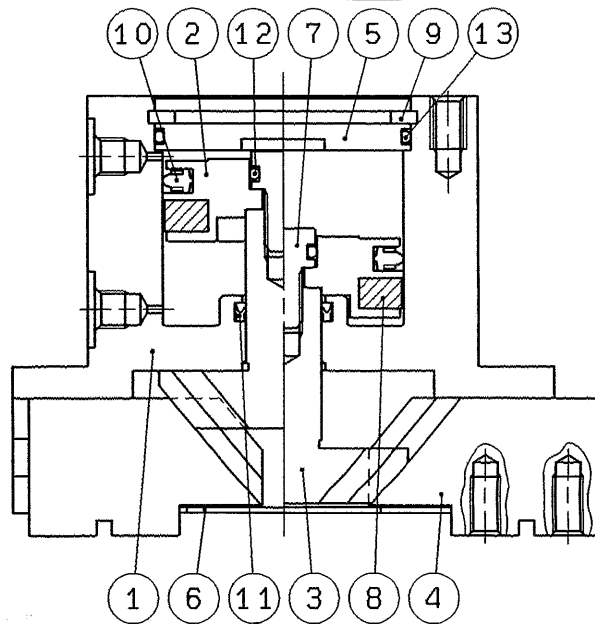

Component parts

No.	Description	Material	Remarks
1	Body	Aluminum alloy	Hard alumite treatment
2	Piston	Aluminum alloy	Hard alumite treatment
3	Cam	Carbon steel	Heat and special treatment
4	Finger	Carbon steel	Heat and special treatment
5	Cap	Aluminum alloy	Hard alumite treatment
6	End plate	Stainless steel	
7	Piston bolt	Stainless steel	
8	Rubber magnet	Synthetic rubber	
9	C-shape snap ring	Carbon steel	Nickel plating
10	Piston packing	NBR	
11	Rod packing	NBR	
12	Gasket	NBR	
13	Gasket	NBR	

Replacement part/Packing set

Part Number

Model	Packing set No.	Contents
MHSL3-16D	MHSL16-PS	Set containing The above numbers 10, 11, 12 and 13.
20D	MHSL20-PS	
25D	MHSL25-PS	
32D	MHSL32-PS	
40D	MHSL40-PS	
50D	MHSL50-PS	
63D	MHSL63-PS	
80D	MHSL80-PS	
100D	MHSL100-PS	
125D	MHSL125-PS	

*Since individual parts of 10,11,12 and 13 cannot be supplied, order them as a set by using the above part numbers of packing set.

Grease Pack for maintenance ; MH-G01 (NET. 30g)