



# Operation Manual

PRODUCT NAME

## Refrigerated Air Dryer

MODEL / Series

IDFB3E-11□-A,S  
IDFB4E-11□-A,R,T,S,V  
IDFB6E-11□-A,K,R,T,S,V  
IDFB8E-11□-A,K,R,T,S,V  
IDFB11E-11□-A,K,R,T,S,V  
IDFB15E-11□-K,R,T,S,V

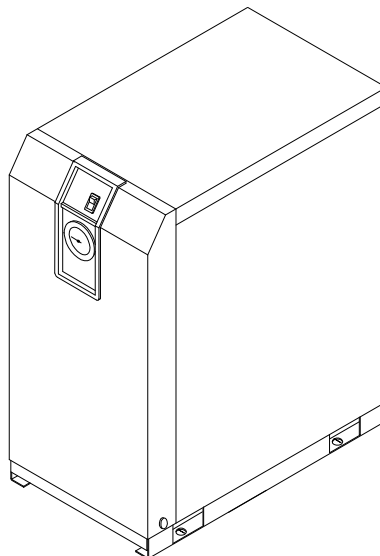

This manual is intended to explain the installation and operation of the product. Only those who have thorough understanding of the fundamental operating procedure or have basic knowledge and skills of handling industrial products are qualified to perform installation and operation.

Please read this manual prior of using the air dryer.  
Keep the manual readily available for reference.

## SMC Corporation

## Dear Customers

Thank you for selecting SMC Refrigerated Air Dryer.

This operation manual must be read and understood thoroughly before using the equipment. It provides all essential information pertaining to safety, as well as, maximizing equipment efficiency in order to extend the life of the equipment.

For safe operation of SMC Thermo-dryer, thoroughly read and follow the safety instructions, as well as regulations stated within ISO 4414<sup>\*1</sup> & JIS B 8370<sup>\*2</sup>.

- \*1) ISO 4414: Pneumatic fluid power – General rules and safety requirements for systems and their components
- \*2) JIS B 8370: Pneumatic fluid power – General rules relating to systems

In addition, it is strongly recommended that you follow all the safety guidelines and regulations set forth by the local government agency for proper installation and usage.

This manual explains about installation and trial operation of the equipment. These tasks should be performed only by individuals with the proper training and have a good understanding of the air dryer.

There is no production amends or financial compensation due to dryers trouble.

This manual contains confidential information proprietary to SMC. It must not be reproduced or disclosed to others, or used in any other way, in part or in whole, except as authorized in writing by SMC.

<p>Caution: Please understand that the contents of this operation manual are subjected to change without prior notice.</p>
--



# Table of Contents

## To Customers

### Chapter i Safety Instructions

<b>i - 1</b>	<b>Warning: Before Using Air Dryer</b> .....	i - 1
i - 1 - 1	Hazard, Warning, and Caution Used in This Manual .....	i - 1
<b>i - 2</b>	<b>Danger Classifications/Position of Hazard warning Label</b> .....	i - 2
i - 2 - 1	Danger Classifications.....	i - 2
i - 2 - 2	Hazard of Electricity .....	i - 3
i - 2 - 3	Hazard of Hot Surface.....	i - 3
i - 2 - 4	Hazard of Rotating Fan Motor.....	i - 3
i - 2 - 5	Danger of Compressed Air Circuit.....	i - 3
i - 2 - 6	Positions of Hazard Warning Label.....	i - 4
i - 2 - 7	Hazard of Refrigerant.....	i - 5
i - 2 - 8	Cautions about Usage.....	i - 6
i - 2 - 9	Other Label.....	i - 6
<b>i - 3</b>	<b>Disposal</b> .....	i - 7
<b>i - 4</b>	<b>Limited warranty and Disclaimer</b> <b>/ Compliance Requirements</b> .....	i - 8

### Chapter 1 Parts Name and Functions

<b>1 - 1</b>	<b>Parts Names and Functions</b> .....	1 - 1
--------------	--	-------

### Chapter 2 Transportation / Installation

<b>2 - 1</b>	<b>Transportation</b> .....	2 - 1
<b>2 - 2</b>	<b>Installation</b> .....	2 - 2
2 - 2 - 1	Location.....	2 - 2
2 - 2 - 2	Tie Down .....	2 - 3
2 - 2 - 3	Air piping .....	2 - 3
2 - 2 - 4	Drain Tube.....	2 - 3
2 - 2 - 5	Electric Wiring diagram .....	2 - 4
<b>2 - 3</b>	<b>Cautions about reinstallation</b> .....	2 - 6

### Chapter 3 Operation / Shutdown

<b>3 - 1</b>	<b>Check points before operation</b> .....	3 - 1
<b>3 - 2</b>	<b>Operation</b> .....	3 - 1
<b>3 - 3</b>	<b>Shutdown</b> .....	3 - 2
<b>3 - 4</b>	<b>Cautions about restart</b> .....	3 - 2
<b>3 - 5</b>	<b>Check points before restart</b> .....	3 - 2
<b>3 - 6</b>	<b>Precautions for long-term non-operation</b> .....	3 - 2

### Chapter 4 Maintenance

<b>4 - 1</b>	<b>Daily inspection</b> .....	4 - 1
<b>4 - 2</b>	<b>Periodical maintenance</b> .....	4 - 1

### Chapter 5 Troubleshooting..... 5 - 1

### Chapter 6 References

<b>6 - 1</b>	<b>Specifications</b> .....	6 - 1
<b>6 - 2</b>	<b>Specifications</b> .....	6 - 1
<b>6 - 3</b>	<b>Dimensions</b> .....	6 - 2
<b>6 - 4</b>	<b>Electric wining diagram</b> .....	6 - 4

---

6 - 5	Compressed Air and Refrigerant Circuit / Operation Principles .....	6 - 6
<b>Chapter 7 Specification for Option A</b>		
7 - 1	Safety instructions .....	7 - 1
7 - 2	Specification .....	7 - 1
7 - 3	Air piping .....	7 - 1
7 - 4	Dryer specifications .....	7 - 1
<b>Chapter 8 Specification for Option K</b>		
8 - 1	Safety instructions .....	8 - 1
8 - 2	Specifications .....	8 - 1
<b>Chapter 9 Specification for Option R</b>		
9 - 1	Safety instructions .....	9 - 1
9 - 2	Specifications of GFCI .....	9 - 1
9 - 3	Cautions for handling the GFCI .....	9 - 1
<b>Chapter 10 Specification for Option S</b>		
10 - 1	Safety instructions .....	10 - 1
10 - 2	Specifications .....	10 - 1
<b>Chapter 11 Specification for Option T</b>		
11 - 1	Safety instructions .....	11 - 1
11 - 2	Specifications .....	11 - 1
11 - 3	Remote operation .....	11 - 2
11 - 4	How to connect the power supply and signal cable .....	11 - 2
11 - 5	Electric wiring diagram .....	11 - 3
<b>Chapter 12 Specification for Option V</b>		
12 - 1	Safety instructions .....	12 - 1
12 - 2	Specifications .....	12 - 1
12 - 3	How to perform maintenance .....	12 - 2
<b>Chapter 13 Service Record</b>		
13 - 1	Service Record .....	13 - 1



## Safety Instructions



Before use, read and comprehend important cautionary notification well on this operation manual.

### i-1 Warning: Before Using Air Dryer

In this chapter, the stated contents are especially about safety.

This Air Dryer is installed downstream of the air compressor to remove moisture. The manufacturer is not responsible for any misuses or misapplications.

This air dryer operates with high voltage and hot surfaces during operation. In addition, this air dryer has high speed rotating fan and motor, which can cause serious injury upon accidental contact. It is advised that you contact the factory or SMC authorized dealer for spare parts or other servicing needs.

We strongly recommend that any one who is working with this air dryer need to read and understand the instructions in this manual beforehand. Often, it's necessary for the people involved, to receive training in order to address the issues of safety and proper application.

When short period power shortage (including instantly recovered shortage) is recovered, it may take a longer starting period than usual starting or may not start due to the protective devices.

In this case, turn off the ON-OFF switch on dryer panel and wait 3 minutes. After this step, turn on the switch to restart. Whenever open the cover panel of this unit, do not miss to turn off the ON-OFF switch, because dryer may start itself when the power supply is recovered.

Connections to a power source where the equipment is exposed to transient stresses exceeding overvoltage category II (as defined in IEC60664-1).

Only connect to TN-S power distribution systems with N conductively connected to PE.

#### **i-1-1 Hazard, Warning, and Caution Used in This Manual**

This equipment is designed with the first priority on safety. However, there are some inherent risks that cannot be eliminated. This manual classifies these risks into the following three categories according to the severity: **DANGER**, **WARNING** and **CAUTION**. Read the warning statements carefully and thoroughly understand them before operating or performing maintenance on the unit.



#### **DANGER**

“DANGER” indicates that there is an imminence hazard that will cause serious injury or death if not avoided.



#### **WARNING**

“WARNING” indicates that there is a hazard that may cause serious injury or death if not avoided.



#### **CAUTION**

“CAUTION” indicates that there is a hazard that may cause minor injury.

**i-2 Danger Classifications & Position of Hazard warning Labels**

To help you recognize the hazards, the unit utilizes special graphics to indicate different hazards. Confirm the contents of the hazards and the location of the labels before operation.

 <b>Warning</b>
<ul style="list-style-type: none"> <li>• <b>Only properly trained, qualified personnel are allowed to perform tasks such as: Operation, installation, relocation of equipment and maintenance works.</b></li> <li>• <b>Should any problem occurs, address it according to instruction in this manual.</b></li> <li>• <b>Identify problems following the guidelines in Chapter 5 for Troubleshooting before proceed with maintenance works.</b></li> <li>• <b>The equipment should not be turn on in the event of any problems. When the equipment gets out of order, shutdown immediately, and contact for service</b></li> </ul>

**i-2-1 Danger Classifications**

Specific danger classification of this equipment is as follows.

**Hazard of Electricity**

Since this equipment operates with high voltage, there is the danger of electric shock. This special symbol is used, along with key words: “CAUTION”, “WARNING” or “DANGER”, on the equipment and in this manual.

**Hazard of Hot Surface**

Since this equipment becomes hot while running, there is the danger of burn injury. This special symbol is used, along with key words: “CAUTION”, “WARNING” or “DANGER”, on the equipment and in this manual.

**Hazard of Rotor**

Since this equipment has parts that rotate at high speed while running, there is the danger of bodily injury. This special symbol is used, along with key words: “CAUTION”, “WARNING” or “DANGER”, on the equipment and in this manual.



## i-2-2 Hazard of Electricity

**Warning**

Inside of this equipment, there is a power-supplying section with high voltage separated by the cover panel. Do not operate the equipment with the cover panel off.

## i-2-3 Hazard of Hot Surface

**Warning**

Since this equipment has parts that become hot during operation, there is the danger of burn-associated injuries. These parts remain hot even after power is off. Wait until the unit has cooled down before touching.

## i-2-4 Hazard of Rotating Fan Motor

**Warning**

Since this equipment has parts that rotate during operation, there is the danger of injury resulting from direct contact. The fan and rotor will start/stop automatically. Thus, do not work on them when power is on.

## i-2-5 Danger of Compressed Air Circuit

**Warning**

Before replacing or cleaning parts, be sure to relief the pressure remained inside of the equipment until the gauge indicates "0". High pressure can propel object at high velocity and cause injury.

## i-2-6 Positions of Danger Warning Label

	<b>Warning</b>
<ul style="list-style-type: none"> <li>▪ Read with caution and pay attention to the notations of danger warning labels.</li> <li>▪ Do not remove or rub danger warning labels.</li> <li>▪ Confirm the positions of danger warning labels.</li> </ul>	

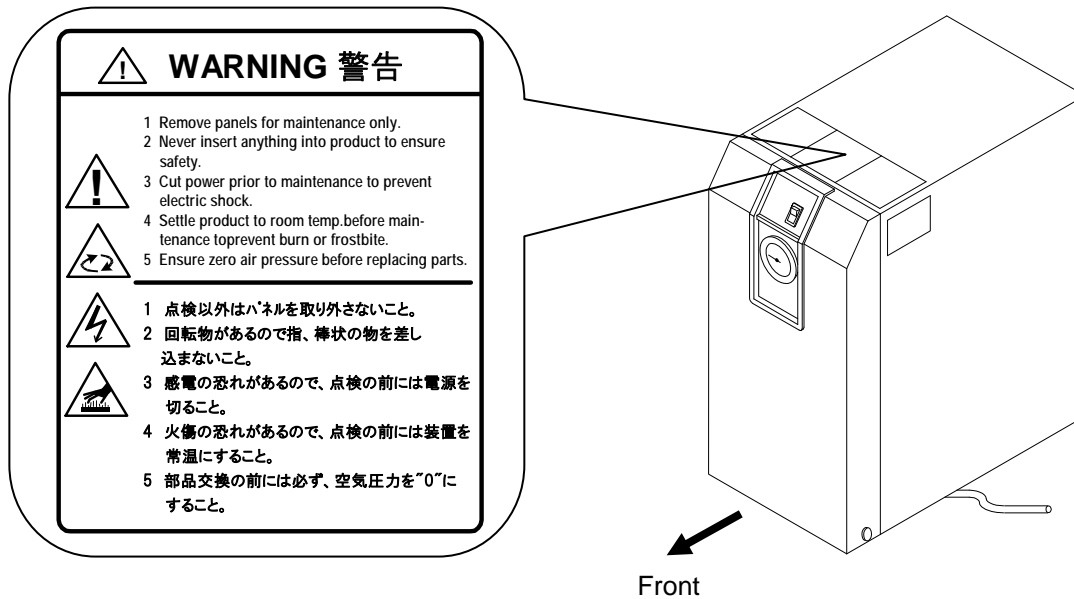



## i-2-7 Hazard of Refrigerant



## Caution

- This equipment uses Fluorocarbon (HFC) as a refrigerant.
- It is strictly forbidden to emit Fluorocarbon into the atmosphere. Before you repair the refrigerant circuit, you should collect the refrigerant with proper evacuation system. The collected refrigerant should be properly recycled by qualified agency. Only personnel with proper credential are allowed to handle refrigerant.
- Only properly trained qualified personnel are allowed to remove the cover panel of the equipment.
- The quantity and the type of Fluorocarbon are mentioned on the specification label. See Page i - 6, i - 7.

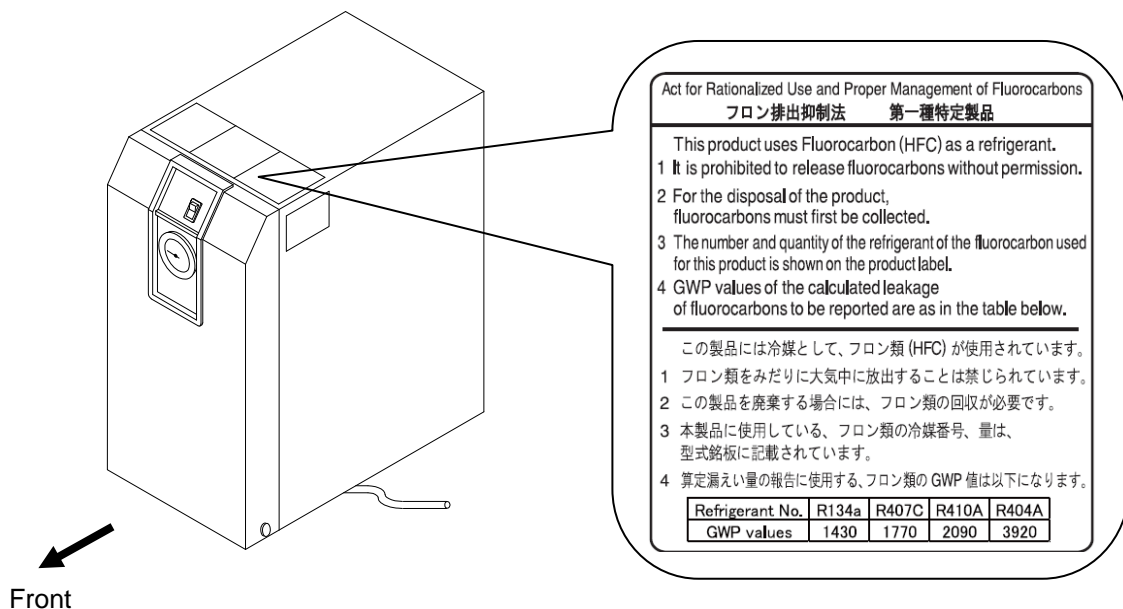

i-2-8 Cautions about Usage

	<b>Warning</b>
<p>Please follow the instructions on all warning labels. Do not remove or deface warning labels, and confirm the location of warning labels.</p>	

**CAUTION 注意**

---

- 1 Read manual before operation.
- 2 Ensure ventilation and maintenance space.
- 3 Keep water away from the product.
- 4 Secure In / Out connector with spanner during piping.
- 5 Wait 3 minutes before restart.
- 6 Ensure Running Condition / Evaporating Temp. in green zone.

---

- 1 ご使用前に必ず取扱説明書を読んでください。
- 2 通風、メンテナンススペースを確保してください。
- 3 雨や水滴がかからないようにしてください。
- 4 IN/OUTポートをスパナで固定して配管してください。
- 5 再起動は運転停止3分後に行ってください。
- 6 RUNNING CONDITION・蒸発温度計はグリーン帯で使用してください。

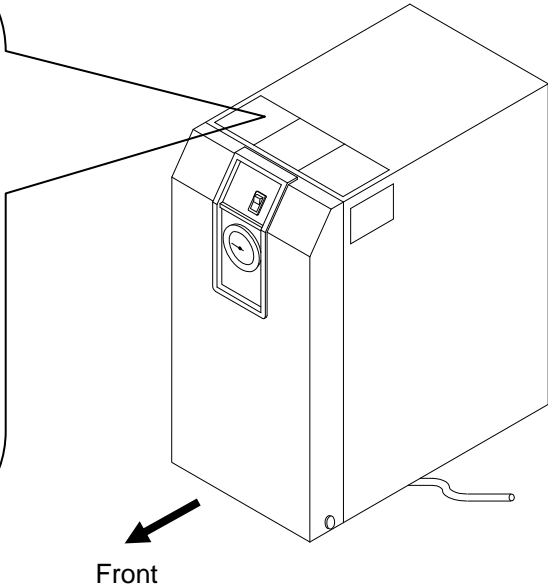

i-2-9 Other Label

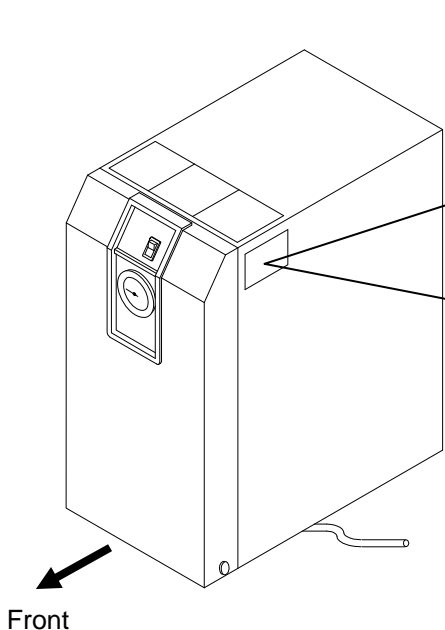

**SMC AIR DRYER**

---

MODEL  
VOLTAGE  
MCA  
MOPD  
COMPRESSOR RLA/LRA  
FAN MOTOR HP/FLA  
AIR FLOW RATE  
MAX. INLET PRESS.  
MAX. INLET TEMP.  
MAX. AMBIENT TEMP.  
MIN. AMBIENT TEMP.  
REFRIGERANT R407C  
LO. SIDE PRESS.  
HI. SIDE PRESS.  
WEIGHT  
SERIAL No.  
MAKER

Akihabara UDX 15F,4-14-1  
Sotokanda, Chiyodaku,  
Tokyo 101-0021, Japan

LISTED

AIR DRYER  
26WZ

MADE IN JAPAN      \*123456789\*

**i-3 Disposal**

When you dispose of the equipment, you should collect the refrigerant and the refrigerant oil inside the refrigerant circuit.

 <b>Caution</b>
<p><b>This equipment contains Fluorocarbon HFC.</b></p> <p><b>It is strictly forbidden to emit Fluorocarbon into the atmosphere. Before you repair the refrigerant circuit, you should collect the refrigerant with proper evacuation system. The collected refrigerant should be properly recycled by qualified agency. Only personnel with proper credential are allowed to handle refrigerant.</b></p> <p><b>Only properly trained and qualified personnel are allowed to remove the cover panel of the equipment.</b></p> <p><b>The quantity and the type of Fluorocarbon are mentioned on the specification label. See Page i - 6, i - 7.</b></p>

 <b>Caution</b>
<p><b>Dispose of the refrigerant and refrigerant oil according to the regulation of local government.</b></p> <p><b>Only personnel with proper credential are allowed to collect refrigerant and refrigerant oil.</b></p> <p><b>Only properly trained and qualified personnel are allowed to remove the cover panel of the equipment.</b></p> <p><b>For any questions, please contact our factory or SMC authorized dealers.</b></p>

## **i-4 Limited warranty and Disclaimer / Compliance Requirements**

The product used subject to the following "Limited warranty and Disclaimer" and "Compliance Requirements. Read and accept them before using the product.

### **Limited warranty and Disclaimer**

1. The warranty period of the product is 1 year in service or 1.5 years after the product is delivered. Also, the product may have specified durability, running distance or replacement parts. Please consult your nearest sales branch.
2. For any failure or damage reported within the warranty period which is clearly our responsibility, a replacement product or necessary parts will be provided.  
This limited warranty applies only to our product independently, and not to any other damage incurred due to the failure of the product.
3. Prior to using SMC products, please read and understand the warranty terms and disclaimers noted in the specified catalog for the particular products.

### **Compliance Requirements**

1. The use of SMC products with production equipment for the manufacture of weapons of mass destruction (WMD) or other weapon is strictly prohibited.
2. The exports of SMC products or technology from one country to another are governed by the relevant security laws and regulation of the countries involved in the transaction. Prior to the shipment of a SMC product of a SMC product to another country, assure that all local rules governing that export are known and followed.

### **Caution**

**The Product is provided use in manufacturing industries.**  
**The product herein described is basically provided for peaceful use in manufacturing industries.**  
**If considering using the product in other industries, consult SMC beforehand and exchange specifications or a contact if necessary. If anything is unclear, contact your nearest sales branch.**

### **Caution**

**SMC products are not intended for use as instruments for legal metrology.**  
**Measurement instruments that SMC manufactures or sells have not been qualified by type approval tests relevant to the metrology (measurement) laws of each country. Therefore, SMC products cannot be used for business or certification ordained by the metrology (measurement) laws of each country.**

# 1 Parts Name and Functions

## 1-1 Parts Name and Functions

- IDFB3E

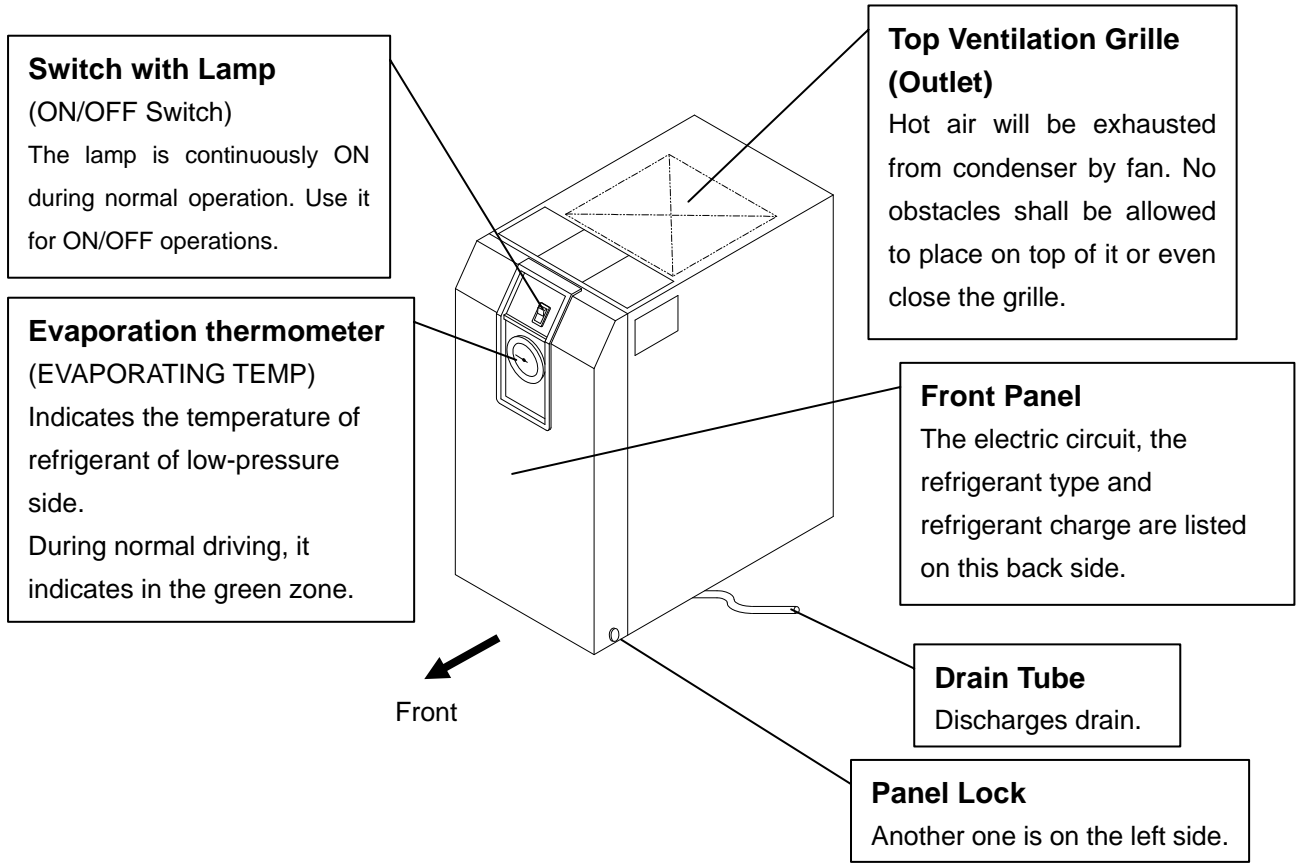

No Front Panel

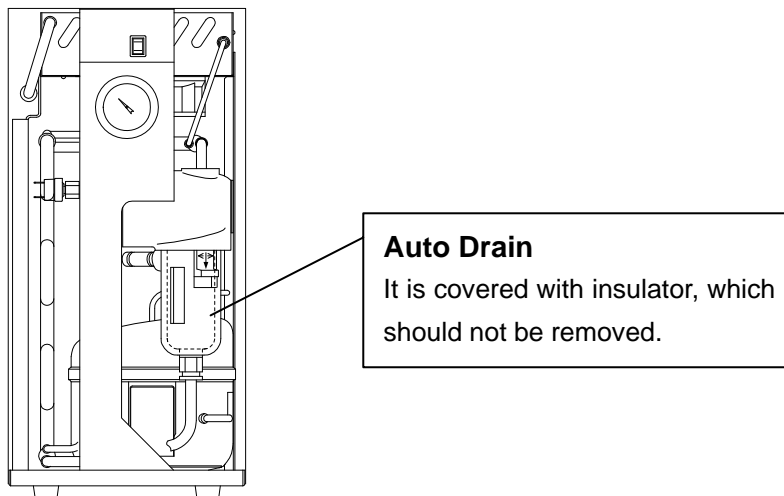

• IDFB3E

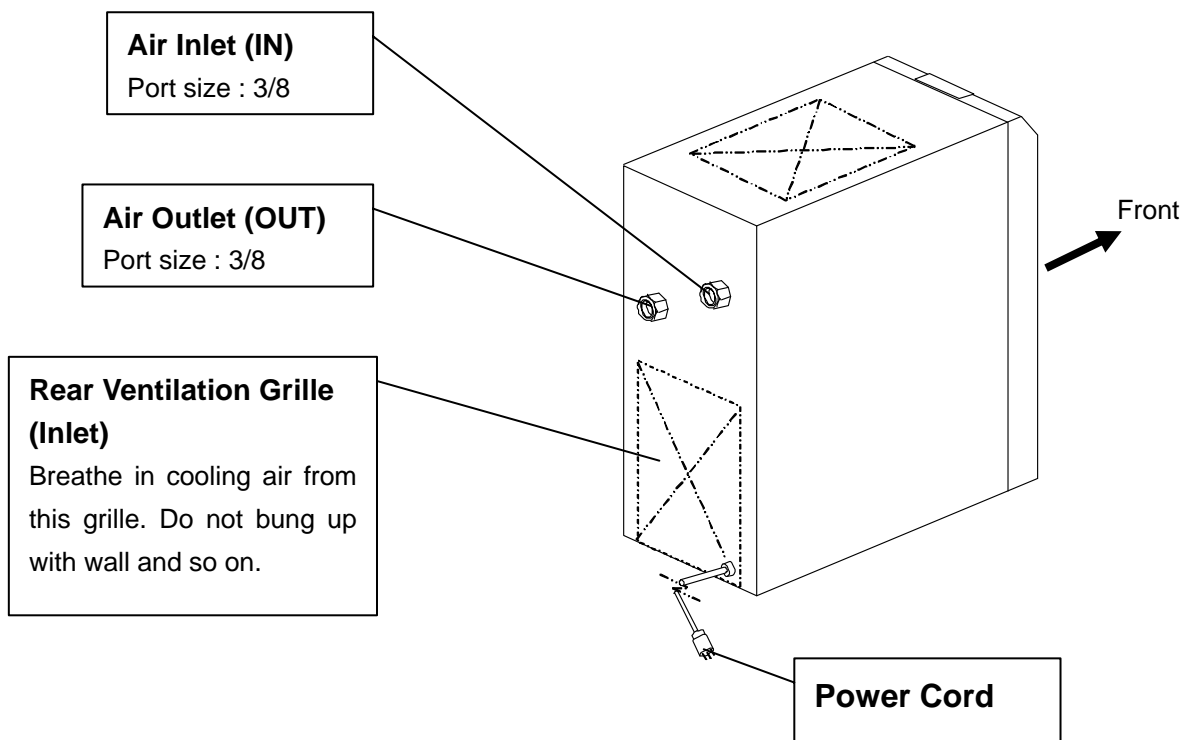

• IDFB4E to 15E

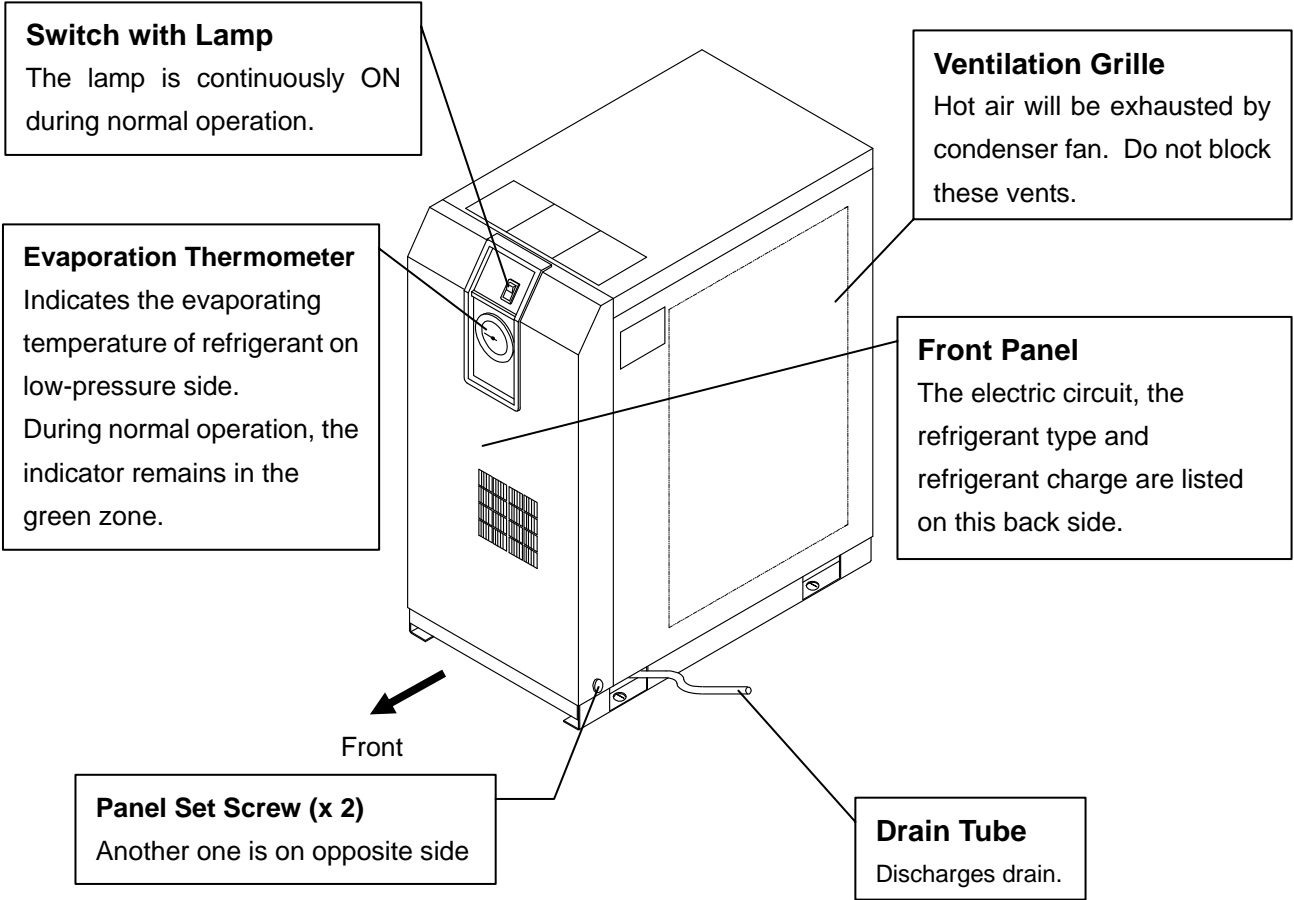

View with Front Panel removed

IDFB4E to 11E

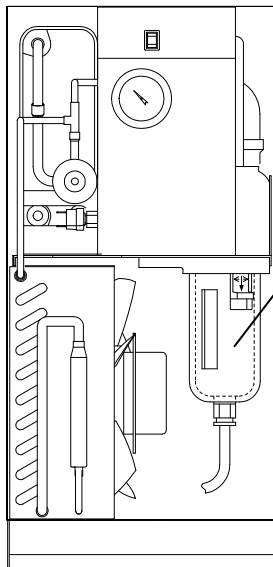

**Auto Drain**  
Do not remove the insulation on the auto drain.

IDFB15E

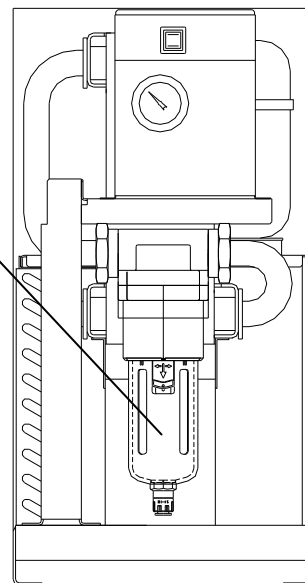

- IDFB4E to 15E

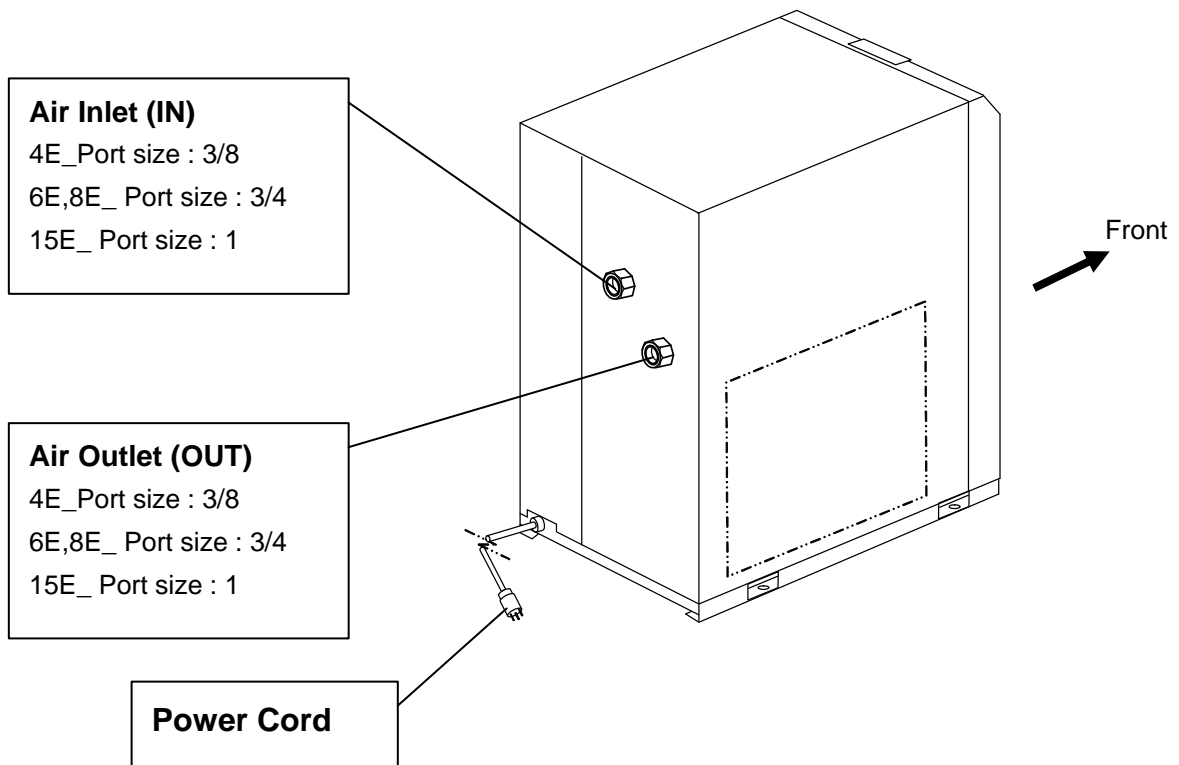



**2****Transportation / Installation****Warning**

- **Only properly trained, qualified personnel are allowed to perform tasks such as: Operation, installation, relocation of equipment and maintenance works.**
- **Strongly recommend to prepare the spare dryer when applying the dryer for important equipment or system.**

**2-1 Transportation**

When you transport the equipment, you should follow the instructions below:

- You should lift the equipment from the base surface with careful attention to prevent tipping over.
- Do not lay the equipment sideways, or you will damage the equipment.
- Do not suspend the equipment from the ceiling or hang from the wall.
- Do not transport the product with any part such as an air filter mounted on the fittings at the air inlet or outlet port of the product. If it is unavoidable to transport the product with such a part mounted, support the mounted part with a bracket to prevent the product from being affected by vibration during transportation.

**Warning**

This equipment is heavy.

Each model IDFB3E to15E weights about 45lbs (20kg) or more. It must be transported by more than one person, a forklift is necessary.

## **2-2 Installation**

### **2-2-1 Location**

The equipment should not be used or stored in the following conditions: Those conditions will cause not only malfunction but also failures.

- Environment where the equipment is exposed to rainwater, moisture, salt water or oil.
- Locations where the equipment is exposed to dust or particles
- Locations where the equipment is exposed to flammable, combustible or explosive fumes.
- Locations where the equipment is exposed to corrosive gas or solvent.
- Locations where the equipment is exposed to direct sunlight or radiated heat.
- Locations where ambient temperature is beyond following range:
  - On-stream: 36 to 104° F (2 to 40°C)
  - Storage: 32 to 122° F (0 to 50°C)
  - (when there is no drain water inside of the piping)
- Locations where temperature changes rapidly.
- Locations where strong electromagnetic noise is generated.
- Circumstances where static electricity is produced or discharged through the body of the equipment
- Locations where strong high frequency shock wave is generated
- Locations where danger of thunder is apparent.
- Locations where loading on vehicles, marine vessels, and so on
- Locations where altitude is higher than 2,000 meters
- Circumstances where strong vibration or impact are transmitted.
- Circumstances where too much force and weight are put on the body of the equipment that causes it to deform.

#### ***IDFB Series***

- Circumstances where not enough clearance spaces to do maintenance
  - Spaces needed for maintenance
  - Front : 2feet (0.6m)
  - Rear : 2feet (0.6m)
  - Top : 2feet (0.6m)
  - Right : 2feet (0.6m)
  - Left : 2feet (0.6m)
- Locations where ventilation grille of the equipment can be blocked.
- Place where rejection style air of air compressor or other driers (hot wind) is inhaled.
- Place where rapid pressure fluctuation and fluid velocity variation happen

### 2-2-2 Tie Down

- The air dryer should be installed on a vibration-free, stable, horizontal, flat surface.
- Refer to “Chapter6 6-3 Dimensions” for the dimensions.
- This model should be installed using anchor bolts (not included) to prevent shifting during a potential earthquake.

### 2-2-3 Air piping

- Connection to the inlet and outlet of compressed air should be made removable by using union or similar connection.
- Support the IN/OUT ports with a wrench during tightening or loosening of fittings.
- Do not allow the equipment to support the weight of the piping.
- Isolate the vibration generated by the compressor.
- If the temperature of compressed air on the inlet side is higher than 122° F (50°C), place an aftercooler unit after the air compressor.
- If the air supply makes high pressure fluctuation (pulsation), take any countermeasures such as installing air tank.
- Clean pipes and fittings before use and select a suitable filter to prevent dust, oil or chips from entering the air dryer, which can cause failure to the equipment.
- Use pipes and fittings that can withstand the operating pressure and temperature of the compressed air. Make sure all connections are leak-free.
- Provide bypass piping to make it possible to do maintenance without stopping the air compressor.
- Please set up the filter in the drier secondary for the drain dispersion prevention when a rapid pressure fluctuation and the fluid velocity variation happen..

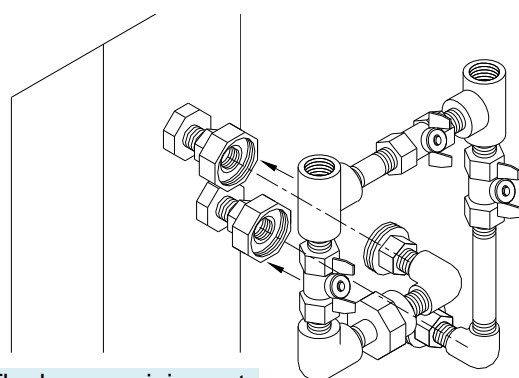

The bypass piping sets

We recommend the bypass piping sets available separately as accessories.

### 2-2-4 Drain Tube

- A polyurethane tube (3/8inch) O.D. is attached to the auto drain. The end of the tube is open to atmosphere to let drain flow through the tube into a collector or drain pipe.
- The compressed air is used to push out the drain periodically. Fix the outlet end of the tube in order to prevent whipping action during discharge.
- Install the drain tube in such a way so that no drain is trapped.
- During installation, make sure the dryer does not sit on the drain tube which is at the bottom of the unit. Be careful to avoid the dryer from crushing the tube during installation.

**Warning**

- To handle drain discharge, follow the safety guidelines such as wearing protective goggles, apron, and gloves.
- In cases where oil is mixed in the wastewater discharged from the auto drain, the liquid would be considered as toxic waste and treatment is necessary in accordance with local regulations.

**2-2-5 Electric Wiring****Warning**

- Only properly trained and qualified personnel are allowed to perform wiring work.
- Before wiring, you must disconnect the power. Do not work under any energized conditions.
- Supply power from a stable source that is free from the effect of surge.
- Referring to “6-1 Specifications,” make sure to install a GFCI breaker that has the right short circuit capacity and load capacity.
- Supply power of the equipment should meet the specifications on page 6-1.
- The equipment must be grounded for safety.
- Do not connect ground wire to a water pipe, a gas pipe, or a lightning rod.
- Do not plug too many leads into a single socket.
- The customer must prepare for countermeasures of the power failure. The dryer may not start normally at the moment of power failure.
- Circuit breaker must be properly selected to meet safety standard of local regulations.
- Always be sure to connect the protective conductor first, disconnect it last in respect to the other connections.
- Be sure that the protective conductor has some additional length in respect to the live conductors, so that it is not subject to mechanical stresses.
- Be sure to install the circuit breaker correctly so that it disconnects all live conductors and so that the operating handle can be easily accessible.

**Specification of power cable**

Prepare following power cable.

Power cable: 16AWG (1.25~1.5mm<sup>2</sup>) , Three-cores (including the ground cable)

Additional length of about 4inch (0.1m) is needed to wire inside of the equipment.

### Length of the power cable

The maximum length of the power cable should be no more than 98feet (30m).

### Connecting to the power supply

- Connect the power cable and the ground to the terminal block

### Wiring procedure

- 1.Remove the terminal block cover or the rear panel.
- 2.Insert the cable through the rubber grommet and connect it to the terminal block (refer to the label on the terminal block).

During wiring work, do not touch other sections except terminal block.

- 3.Insert the screwdriver into terminal block and open spring of terminal.

(The cable insulator must be stripped at 3/8inch (10mm).)

- 4.Insert the cable and remove the screwdriver.
- 5.Re-attach the cover or rear panel after wiring is done.

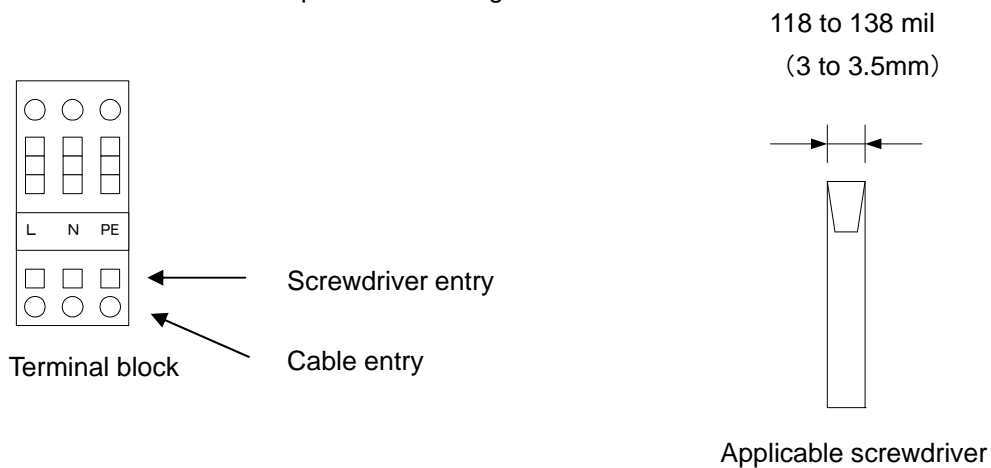

## **2-3Cautions for Reinstallation**

	<b>Caution</b>
<b>Only properly trained, qualified personnel are allowed to perform reinstallation.</b>	

If the equipment is moved and reinstalled in another place after some trial operations, the following instructions must be followed as well as procedures in Chapter 2.

### **Removing the power cable**

**Disconnect the power source before removing the power cable.**

	<b>Warning</b>
<b>Only properly trained, qualified personnel are allowed to perform wiring. Disconnect the power source before wiring. Do not work under energized condition</b>	

### **Disconnecting air pipes**

	<b>Warning</b>
<b>Only properly trained, qualified personnel are allowed to perform piping works. Separate the compressor from the equipment before disconnecting the air pipe. Do not disconnect any piping when there is residual air pressure inside of the pipe.</b>	

Remove the seal tape completely after removing the piping. Loose seal tape can clog up the system.

### **Releasing residual pressure**

Bypass valve should open even after the dryer has been removed.

Close the compressed air inlet and outlet valve.

Unscrew the front panel screws (in 2 places) and remove the front panel.

Open the auto drain residual pressure release valve to release air pressure inside the equipment. Refer to the method of cleaning the auto drain strainer in "Chapter 4 Maintenance" for detail.

# 3 Operation / Shutdown



## Caution

**Only properly trained and qualified personnel are allowed to perform operation/shutdown of the equipment.**

### **3-1 Check points before operation**

Before trial run, check the following points:

- **Installed Conditions:**  
By visual inspection check that the equipment is level.  
Make sure the equipment is tied down with anchor bolts.  
Do not place heavy objects on the top of the equipment. Make sure piping does not add weight to the equipment.
- Power cord, and the ground should be connected firmly.
- Drain tube should be connected correctly.
- Make sure the piping for compressed air is connected correctly.
- Make sure the ball valve located next to the auto drain opened.

### **3-2 Operation**

Start operation according to the procedure below.

- Turn on the breaker of the main power supply. Then, turn ON the ON/OFF switch.
- The lamp will light up. Few minutes later, the cooling fan will rotate and hot air will be exhausted from the ventilation grille.  
Location of the ventilation grille: Right Side
- Open the IN/Out side valve slowly. Make sure the bypass valve is completely closed. Confirm there are no air leaks.
- Depending on the condition of compressed air or ambient temperature, the cooling fan sometimes alternates between start/stop at the beginning. Then, the refrigerant compressor will start and the pointer of the evaporating temperature will indicate in the green zone. If the pointer indicates higher than the green zone, refer to "Chapter 5 Troubleshooting."
- After running for a while, moisture will be discharging from the drain tube automatically.



## Caution

- **Avoid frequent On/Off operation, which may cause problems.**
- **The auto drain used for the equipment has a structure that closes the valve with air pressure higher than 22psi (0.15MPa) .**  
**Therefore, until the pressure increase, air will be emitted form the drain outlet at the begining of opening the IN side valve. Keep in mind that sometime the pressure cannot increase enough with air compressor that has low discharge flow rate.**
- **Avoid using this product under the condition which has sudden pressure/flow rate changes. Otherwise, drain (condensed water) may flow out to the secondary piping.**

### **3-3 Shutdown**

- ① Turn off the ON/OFF switch.
- ② The lamp will go out and then, the operation will stop. Depending on the condition of operation, hot air continues to be emitted from the ventilation grille by the cooling fan for a while after turning off the switch.

### **3-4 Cautions about restart**

- Wait at least 3 minutes before restarting the air dryer after it has been shut down. Failure to do this may cause safety devices to trip due to over load. If it is not possible to restart, refer to “Chapter 5 Troubleshooting.”

### **3-5 Check points before restart**

Check following points before you start operation. If any abnormalities occur, immediately stop the operation. Turn off the ON/OFF switch follow by the breaker of the main power supply.

- There are no air leaks.
- Air pressure, temperature, flow rate, and ambient temperature meet the specifications.
- Moisture is being discharged from the drain tube.
- The pointer of evaporating temperature indicates in the green zone.
- Drainage should not be exhausted from the outlet of the air dryer.
- There are no abnormal sound, vibration, or odor.

### **3-6 Precautions for long-term non-operation**

- If the product will not be operated for more than 24 hours, for example at the weekend, turn off the ILS (Switch with lamp) or power supply, for energy saving and safety. It is also recommended to release the pressure and residual drainage inside the compressed air piping and this air dryer.
- The residual drainage in the air dryer may splash over the outlet when the operation is re-started, so it is recommended to install a filter on the outlet of the air dryer.



4

## Checks and Maintenance

### 4.1 Daily Check Points

Check the following points during normal operation. If you find any problems, immediately stop the operation and refer to “Chapter 5 Troubleshooting”.

- There is no air leakage.
- The running lamp is on during operation.
- Moisture (condensate fluid) is being discharged from the drain tube.
- The pointer of the evaporation thermometer indicates in the green zone when it is running with pressurized air supply.
- The pointer of the evaporation thermometer indicates about 3 to 10°C lower than the ambient temperature when the equipment is suspended with no pressurized air supply.
- There is no abnormal sound or vibration coming from the equipment.
- There are no abnormal smell or smoke coming from the equipment.

### 4.2 Daily Check Points

#### 4-2-1 **Cleaning of ventilation grille(suction grille)**

Clean dust and other foreign particles from the ventilation area with vacuum cleaner or air blow nozzle once a month.

**Caution**

**During air blowing, put on protective glass and mask to prevent dusts from coming into throat or eyes.**

#### 4-2-2 **Service parts**

It is recommended to replace the following parts regularly. The interval values shown in this operation manual depend on the operating conditions (ambient temperature, installation environment, etc.), so that they are for reference.

• Table 1. List of parts to be replaced regularly

Description	Recommended replacement period *Note}
Pressure switch	One Million times.
Fan motor	20,000 hours
Magnetic Contactor, Magnetic Switch	One Million times.

\*Note) If it is mounted by option “T” (With terminal block for power supply , run , alarm signal and remote operation) or special order.

#### 4-2-3 **Auto drain strainer**

Remove the dust deposited in the auto drain bowl assembly every month. Use neutral detergent for cleaning. If the degree of dirt is heavy and operating failure still continues even after cleaning, replace the product. Also, shorten cleaning interval from next time.



## Warning

- Maintenance of the air dryer should only be carried out by someone with sufficient knowledge and experience of air dryers and related equipment.
- Before carrying out maintenance, the important warnings in this manual must be thoroughly read and understood.



## Danger

- When replacing or cleaning parts of the air dryer, be sure to remove the compressed air pressure inside the air dryer to "0". Never remove the case assembly when the air dryer is operated or air pressure remains inside. It is extremely dangerous if compressed air pressure remains inside the air dryer, as parts may come flying off at speed when loosened, or other unexpected accidents.
- This product has parts that become hot during operation and a power supply with high voltage applied. There is a risk of burns due to heat or electrification by high voltage. Even when operation is shut down after switching off the air dryer's illuminated light, there are also charging lines. When working on the charged sections, be sure to switch off the earth leakage breaker installed before starting work.
- As some parts of the air dryer will remain hot, there is a risk of burns due to residual heat after the power is switched off. Do not carry out replacement work until the temperature of these parts has fallen to 50°C or less. Wait approximately 10 to 15 minutes as a guide.
- When carrying out maintenance work on the auto drain strainer and auto drain, there is a risk of touching the drain fluid during work. Please follow the safety procedure for operators specified by customer. (Example: carry out work wearing safety glasses, apron and gloves to prevent discharged fluid from touching the human body.)
- Use neutral detergent solution to clean parts such as the auto drain strainer and auto drain. Never use solvent such as thinner.
- When removing the outer casing panel or case assembly of the auto drain, wear gloves to prevent injuries.

### [How to clean and replace the auto drain/strainer]

When carrying out maintenance work on the auto drain and auto drain strainer, please follow the steps below.

#### (1) Removal of the bowl assembly

- 1) Turn off the illuminated ON/OFF switch.
- 2) Disconnect the earth leakage breaker at the power supply or unplug the power plug from the socket.
- 3) Fully close the inlet and outlet valves. Only open the bypass when compressed air is required during work.
- 4) Only remove the outer panels when necessary for work.
- 5) Open the residual pressure release cock at the drain tube connection port to release air and drain fluid left in the product. (Leave the drain tube connected and hold it so that it does not get twisted.)
- 6) Take care because condensate fluid may spurt out due to residual air pressure in the product.
- 7) Remove the drain tube.
- 8) Pull out the tube while pushing up the drain tube release bush.

- 9) Loosen the vinyl tie fixing the bowl insulation and remove the bowl insulation.
- 10) Hold the bowl assembly lightly and pull down the lock button with thumb.  
Then, turn the bowl assembly to the left (or right) to 30° to align the marks.  
Release your thumb from the lock button and slowly pull down the bowl assembly (vertically) to remove it.
- 11) Remove the auto drain strainer and clean it.  
Take care not to cut your hand with the sharp edges of the strainer.
- 12) Pour solution of neutral detergent into the assembly and shake it well to clean.

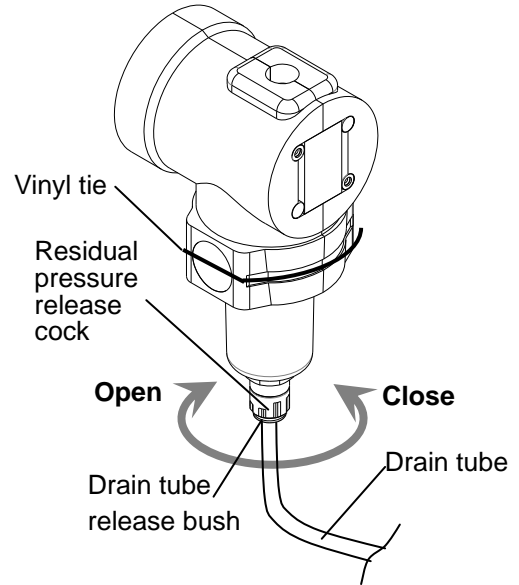

(2) Mounting of the bowl assembly

- 1) Check the bowl packing for damage such as scratches, twisting or foreign particles attached to it.  
Then, apply grease thinly and fit it in the groove in the bowl assembly.
- 2) Fit the auto drain strainer to the case assembly and fit it into the drain separator body.  
Turn it until the lock button clicks.
- 3) Try to turn the bowl assembly gently and check that it does not turn.  
If it turns, start again from fitting the bowl assembly to the body.
- 4) Attach the bowl insulation to the bowl assembly and fix the bowl assembly with the vinyl tie.
- 5) Close the residual pressure release cock and mount the drain tube and front panel as they were.
- 6) When reapplying compressed air to the air dryer, first open the valve on the inlet side slowly.  
Check for compressed air leakage and if everything is all right, open the valve on the outlet side.
- 7) If the auto drain strainer or case assembly is damaged or very dirty, replace it with a new one.

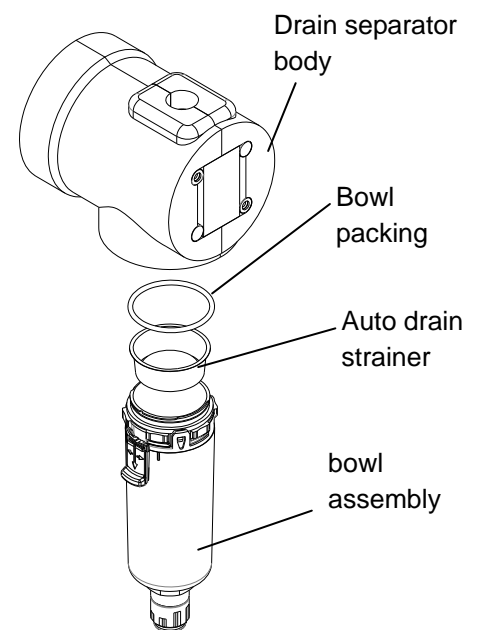
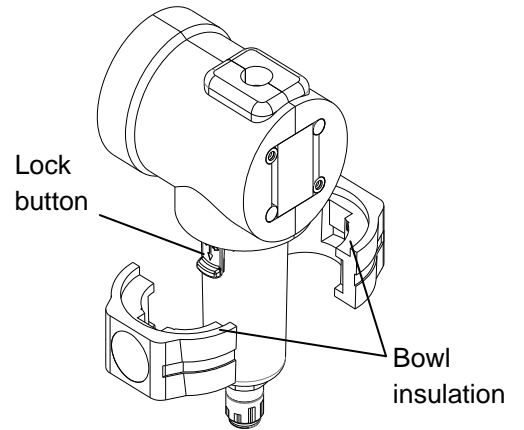

**Replacement part of Auto drain**

Part no.	Description	Qty.	Applicable model	Remarks
AD38-A	Bowl assembly	1	IDFB3E/4E-**	With bowl packing
AD38N-Z-A		1	IDFB3E/4E-**N	
AD48-A		1	IDFB6E~15E-**	
AD48N-Z-A		1	IDFB6E~15E-**N	

Note) The drain separator body can not replaced.

**Replacement part of Auto drain strainer and Bowl packing**

Part no.	Description	Qty.	Applicable model
IDF-S0001	Auto drain strainer	1	IDFB3E/4E
IDF-S0002		1	IDFB6E~15E
C32FP-260S	Bowl packing	1	IDFB3E/4E
C42FP-260S		1	IDFB6E~15E

**Bowl insulation**

Part no.	Description	Qty.	Applicable model	Remarks
IDF-S1932	Bowl insulation	1	IDFB3E/4E	2 pieces per model
IDF-S1933		1	IDFB6E~15E	

## 5

## Troubleshooting

**5-1 Cause and countermeasure of errors**

Should any problem occur, inspect the following table, and if the problem cannot be solved, shut off the power supply and then contact one of our sales offices for further instructions.

Problem	Probable Causes	Remedy
Although the switch with lamp is turned on, the lamp does not light up and the product does not start operating.	The power supply cable has been loosened or disconnected.	Perform proper connection on the power cord and plug.
	The ground fault circuit interrupter is not turned ON.	Check the capacity of the ground fault circuit interrupter. - Check the product was not restarted within 3 minutes after being stopped. - Turn on the ground fault circuit interrupter and try to operate. If the ground fault circuit interrupter turns back off, the insulation failure of the product is suspected. Turn off the power supply and contact SMC.
Running lamp extinguishes and compressor stops during operation but resumes normal operation illuminating the lamp after a period of time.	The product is installed in an inappropriate location. Ambient temperature is excessive.	- Improve ventilation condition and reduce the ambient temperature as much as possible..
	The ventilation port is obstructed by a wall or clogged with dust.	- Keep the product 600mm or more away from the surrounding walls. - Clean the ventilation ports once every month.
	The compressed air temperature is too high.	- Improve the ventilation in the location where the air compressor is installed, or decrease the ambient temperature to allow the discharge air temperature of the air compressor to go down. - Install an aftercooler after the air compressor to reduce the temperature.
	The fluctuation of the power supply voltage is too large.	- Install a power supply transformer or use a different power supply to provide appropriate voltage. - The fluctuation of the power supply voltage should be kept within +/-10% of the rated voltage.

Problem	Probable Causes	Remedy
The evaporation thermometer is over the green area without hot air coming from the ventilation port (exhaust port). (The compressor for refrigeration has stopped with the lamp lit up.	The product is installed in an inappropriate location. Ambient temperature is excessive.	- Improve ventilation condition and reduce the ambient temperature as much as possible.
	The ventilation port is obstructed by a wall or clogged with dust.	- Keep the product 600mm or more away from the surrounding walls. - Clean the ventilation ports once every month.
	The compressed air temperature is excessive.	- Improve the ventilation in the location where the air compressor is installed, or decrease the ambient temperature to allow the discharge air temperature of the air compressor to go down. - Install an aftercooler after the air compressor to reduce the temperature.
	The fluctuation of the power supply voltage is too large.	- Install a power supply transformer or use a different power supply to provide appropriate voltage. - The fluctuation of the power supply voltage should be kept within +/-10% of the rated voltage.
	The built-in overload relay of the compressor for refrigeration has started.	- Check the product was not restarted within 3 minutes after being stopped.
The evaporation thermometer is over the green area with hot air coming from the ventilation port (exhaust port).	The product is installed in an inappropriate location. Ambient temperature is excessive.	- Improve ventilation condition and reduce the ambient temperature as much as possible.
	The ventilation port is obstructed by a wall or clogged with dust.	- Keep the product 600mm or more away from the surrounding walls. - Clean the ventilation ports once every month.
	The compressed air temperature is excessive.	- Improve the ventilation in the location where the air compressor is installed, or decrease the ambient temperature to allow the discharge air temperature of the air compressor to go down. - Install an aftercooler after the air compressor to reduce the temperature.
Moisture is generated at the downstream of the compressed air line.	The bypass valve is open.	- Be sure to fully close the bypass valve.
	Condensate is not drained from the auto drain.	- Check the draining piping is not used in an upward direction nor bent. - Check the auto drain. - Check the auto drain strainer.
	The pressure fluctuation (pulsation) of the compressed air is too high.	- Install an air tank on the primary side of the dryer. - Avoid intermittent compressed air flow.
	Residual drainage in the air dryer splashes over when the unit is re-started.	- Install a filter on the outlet of the air dryer. - Blow the unit by air to eliminate the residual drainage after stopping or re-starting the operation.
	The piping of a different system without an air dryer joins the piping after the product.	- Install another air dryer (this product) in that system. - Keep the two systems separate.
The compressed air pressure is too large.	The valves at the inlet and outlet of the piping of the product are not fully opened.	- Be sure to fully open the valves at the inlet and outlet of the product.
	The air filter, etc. installed in the compressed air piping has got clogged.	- Replace the element of the air filter. (Follow the Operation Manual of the equipment.)

## 6

## References

## 6-1 Specifications

Specification		Model	IDFB3E	IDFB4E	IDFB6E	IDFB8E	IDFB11E	IDFB15E
Air Flow Rate (ANR) (Note1)	At Expected Outlet Press.Dew Point of 37° F (2.8°C)		10 SCFM (17 m <sup>3</sup> /h)	15 SCFM (25 m <sup>3</sup> /h)	25 SCFM (43 m <sup>3</sup> /h)	41 SCFM (70 m <sup>3</sup> /h)	59 SCFM (100 m <sup>3</sup> /h)	71 SCFM (120 m <sup>3</sup> /h)
	At Expected Outlet Press.Dew Point of 45° F (7.2°C)		11 SCFM (19 m <sup>3</sup> /h)	16 SCFM (27 m <sup>3</sup> /h)	26 SCFM (45 m <sup>3</sup> /h)	43 SCFM (74 m <sup>3</sup> /h)	62 SCFM (106 m <sup>3</sup> /h)	80 SCFM (136 m <sup>3</sup> /h)
	At Expected Outlet Press.Dew Point of 50° F (10°C)		12 SCFM (20 m <sup>3</sup> /h)	17 SCFM (28 m <sup>3</sup> /h)	28 SCFM (47 m <sup>3</sup> /h)	45 SCFM (77 m <sup>3</sup> /h)	65 SCFM (110 m <sup>3</sup> /h)	86 SCFM (147 m <sup>3</sup> /h)
Rated Condition	Operating Pressure	100psig (0.7MPa)						
	Inlet Air Temperature	100° F (37.8°C)						
	Ambient Temperature	100° F (37.8°C)						
	Voltage	115V 60Hz						
Operating Range	Working Fluid	Compressed Air						
	Inlet Air Temperature	41-122° F (5-50°C)						
	MIN. Inlet Air Pressure	22psig (0.15MPa)						
	MAX. Inlet Air Pressure	150psig (1.0MPa)						
	Ambient Temperature	36-104° F (2-40°C) Relative Humidity of 85% or less						
Electrical Specification	Power source	1 φ AC115V±10% 60Hz (Note3)						
	Operating current (Note2)	2.7A	3.0A	3.5A	6.5A	8.5A		
	Power consumption (Note2)	240W	260W	310W	550W	800W		
	GFCI Breaker	Reted Current 15A:Sensivity 30mA						
Condenser	forced air cooling							
Refrigerant	R134a (HFC)							
Refrigerant Charge Quantity		6.3±0.2oz (180±5g)	7.1±0.2oz (200±5g)	8.1±0.2oz (230±5g)	9.5±0.2oz (270±5g)	10.2±0.2oz (290±5g)	12.0±0.2oz (340±5g)	
Thread Type and Size	Thread Symbol "N" (female)	NPT3/8	NPT1/2	NPT3/4			NPT1	
	Thread Symbol "None" With Adapter	Rc3/8	Rc1/2	Rc3/4			Rc1	
Drain Tube	Thread Symbol "N"	3/8inch						
	Thread Symbol "None"	10mm						
Painting Finish	baking finish							
Color	Panel:Urbanwhite1							
Weight		40lbs (18kg)	55lbs (25kg)	57lbs (26kg)	64lbs (29kg)	73lbs (33kg)	110lbs (50kg)	

Note1: The data for SCFM (ANR) is referring to the conditions of 68° F (20°C), 1atm . pressure & relative humidity of 65%.

Note 2: The value is that of under specified condition.

Note 3: When short period power shortage (including instantly recovered shortage) is recovered, it may take a longer starting period than usual starting or may not start due to the protective devices.

## 6-2 Refrigerant with GWP reference

Refrigerant	Global Warming Potential (GWP)	
	Regulation (EU) No 517/2014 (Based on the IPCC AR4)	Revised Fluorocarbons Recovery and Destruction Law (Japanese law)
R134a	1,430	1,430
R404A	3,922	3,920
R407C	1,774	1,770
R410A	2,088	2,090

Note:

1. This product is hermetically sealed and contains fluorinated greenhouse gases.
2. See specification table for refrigerant used in the product.

### 6-3 Dimensions

• IDFB3E-11

Table1. Thread symbol

SYMBOL	DRAIN TUBE SIZE
NONE	10mm
N	3/8

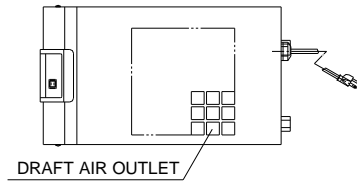
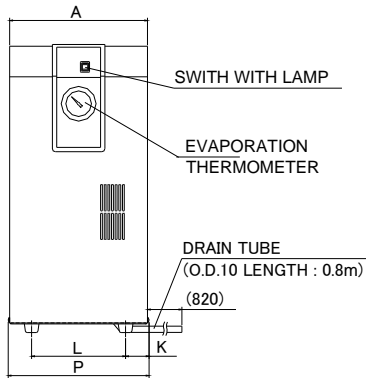

UNIT : inch (mm)

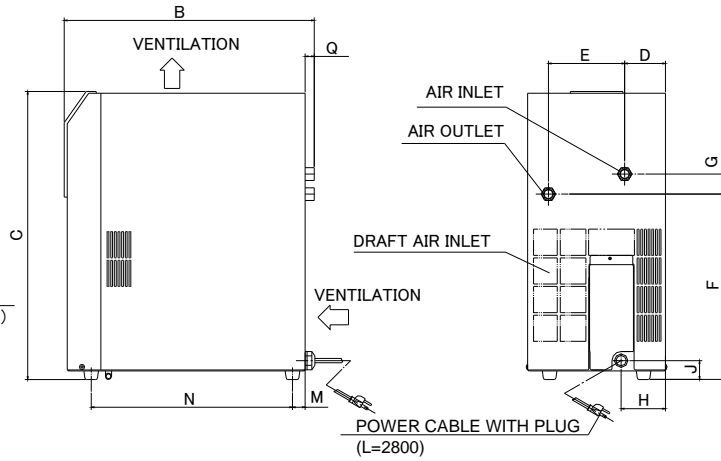

• IDFB4E/6E/8E/11E-11

Table1. Thread symbol

SYMBOL	DRAIN TUBE SIZE
NONE	10mm
N	3/8

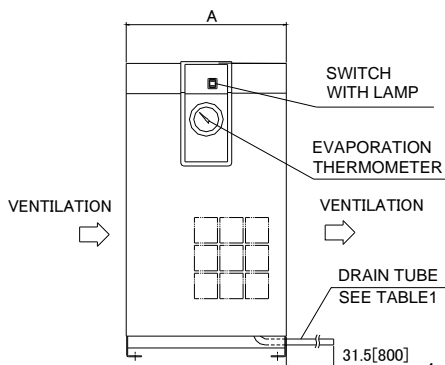

UNIT : inch (mm)

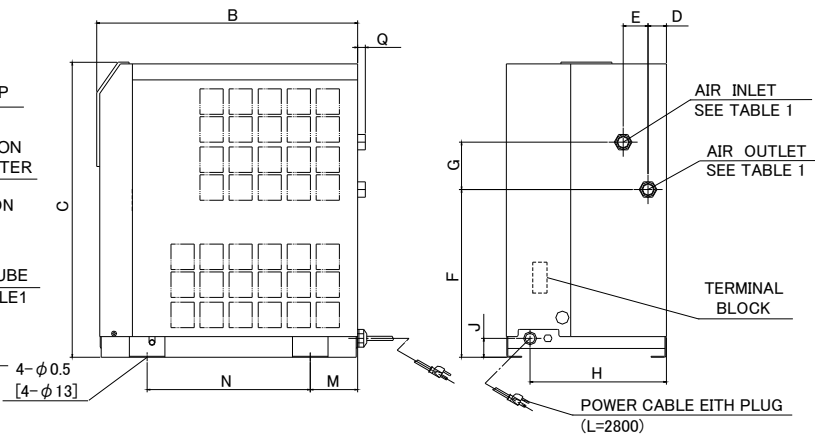



• IDFB15E-11

Table1. Thread symbol

SYMBOL	DRAIN TUBE SIZE
NONE	10mm
N	3/8



UNIT : inch (mm)

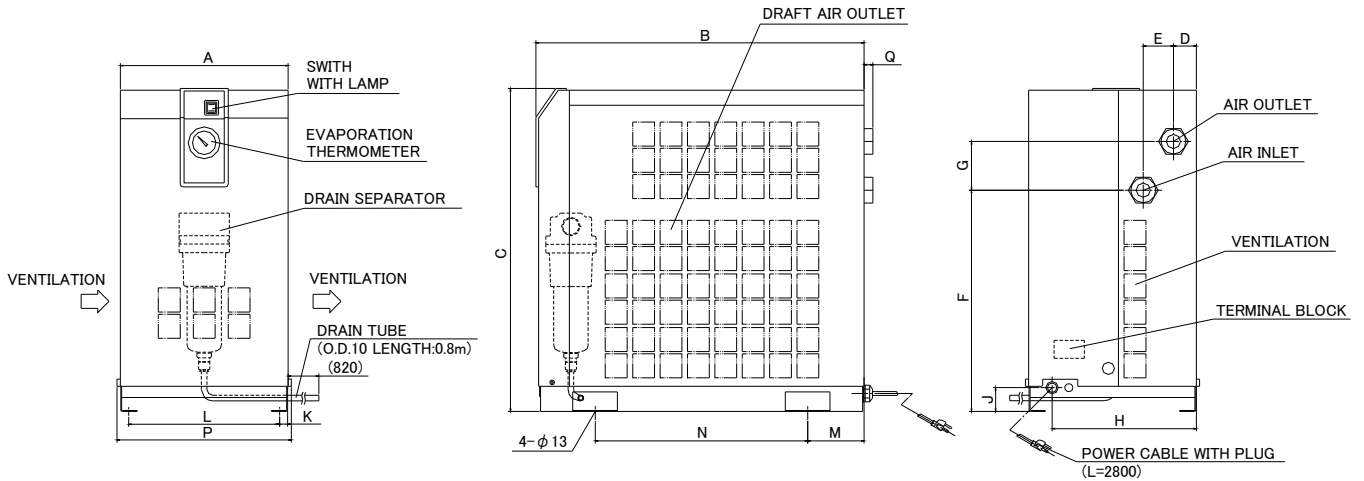

Model	Thread Size	Dimensions (inch [mm])																					
		A	B	C	D	E	F	G	H	J	K	L	M	N	P	Q							
IDFB3E	3/8	8.9 [226]	16.1 [410]	18.6 [473]	26 [67]	4.9 [125]	120 [304]	1.3 [33]	2.9 [73]	1.2 [31]	1.4 [36]	6.1 [154]	0.8 [21]	13.0 [330]	9.1 [231]	0.6 [15]							
IDFB4E	1/2	10.6 [270]	17.8 [453]	17.8 [453]	1.2 [31]	1.7 [42]	11.1 [283]	3.1 [80]	9.1 [230]	1.3 [32]	0.6 [15]	9.4 [240]	3.1 [80]	10.8 [275]	10.8 [275]	0.5 [13]							
IDFB6E	3/4		17.9 [455]													14.0 [355]	0.6 [15]	9.4 [240]	3.1 [80]	10.8 [275]	10.8 [275]	0.6 [15]	
IDFB8E			19.1 [485]	11.8 [300]																			0.6 [15]
IDFB11E			22.4 [568]																				
IDFB15E	1	11.8 [300]	23.7 [603]	22.8 [578]	1.6 [41]	2.1 [54]	16.6 [396]	3.4 [87]	10.2 [258]	1.7 [43]	0.6 [15]	10.6 [270]	4.0 [101]	15 [380]	12.4 [314]	0.6 [16]							

### 6-4 Electrical wiring diagram

#### IDFB3E

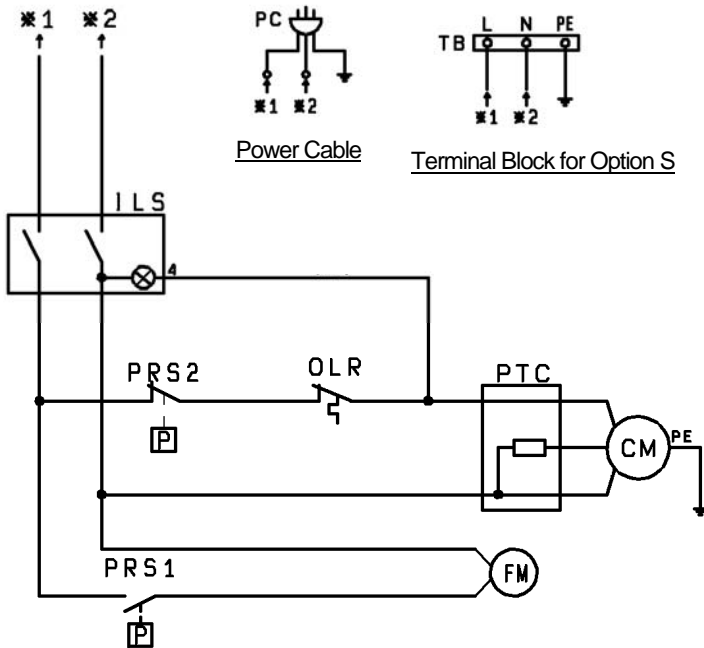

SYMBOL	DESCRIPTION
CM	Compressor Motor
FM	Fan Motor
OLR	Overload Relay (Inside of compressor terminal cover)
PTC	PTC starter
ILS	Switch with Lamp
TB	Terminal Block
MC	Magnetic Contactor

#### IDFB4E / 6E / 8E

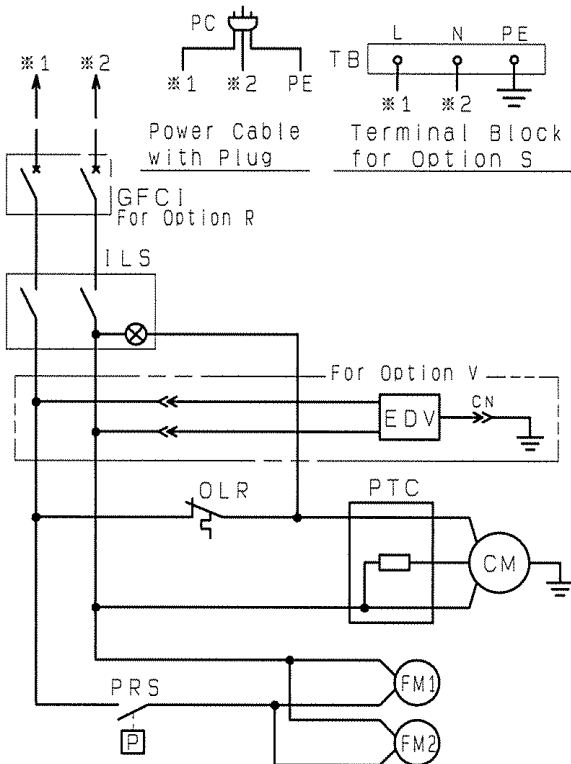

SYMBOL	DESCRIPTION
CM	Compressor Motor
FM1~2	Fan Motor
OLR	Overload Relay (Inside of compressor terminal cover)
PTC	PTC Starter
ILS	Switch with Lamp
PRS	Pressure Switch
TB	Terminal Block
GFCI	Ground Fault Circuit Interrupter
EDV	Electronic Drain Valve

IDFB11E

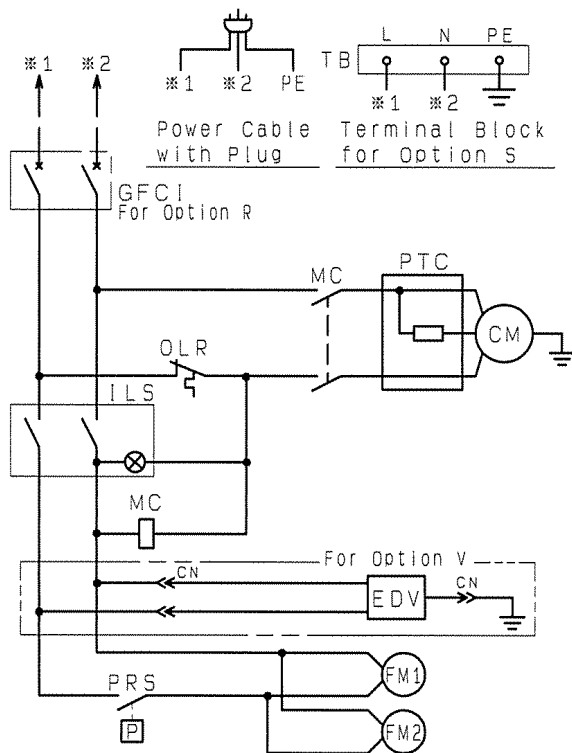

SYMBOL	DESCRIPTION
CM	Compressor Motor
FM1~2	Fan Motor
OLR	Overload Relay (Inside of compressor terminal cover)
ILS	Switch with Lamp
PRS	Pressure Switch
TB	Terminal Block
MC	Magnetic Contactor
GFCI	Ground Fault Circuit Interrupter
EDV	Electronic Drain Valve
PC	Power Cable

IDFB15E

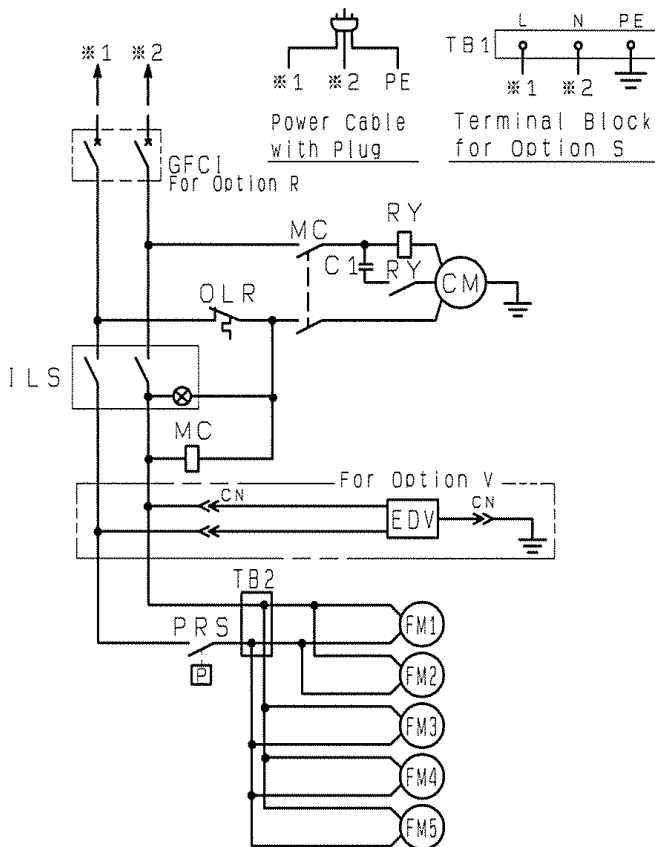

SYMBOL	DESCRIPTION
CM	Compressor Motor
FM1~5	Fan Motor
OLR	Overload Relay (Inside of compressor terminal cover)
C1	Capacitor For Compressor Motor
ILS	Switch with Lamp
PRS	Pressure Switch
TB1~2	Terminal Block
RY	Starting Relay
MC	Magnetic Contactor
GFCI	Ground Fault Circuit Interrupter
EDV	Electronic Drain Valve
PC	Power Cable

**6-5 Compressed Air and Refrigerant Circuit/Operation Principles (BASIC MODEL)**

**IDFB3E-11**

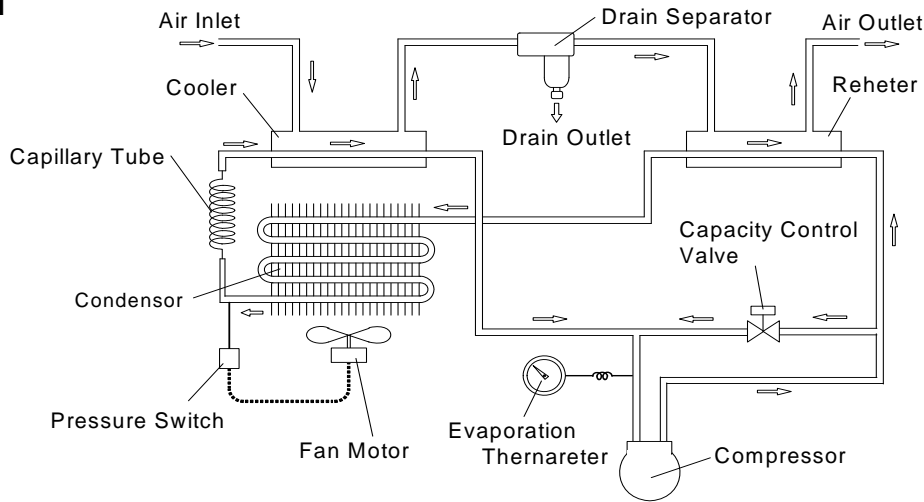

**IDFB4E to 15E-11**

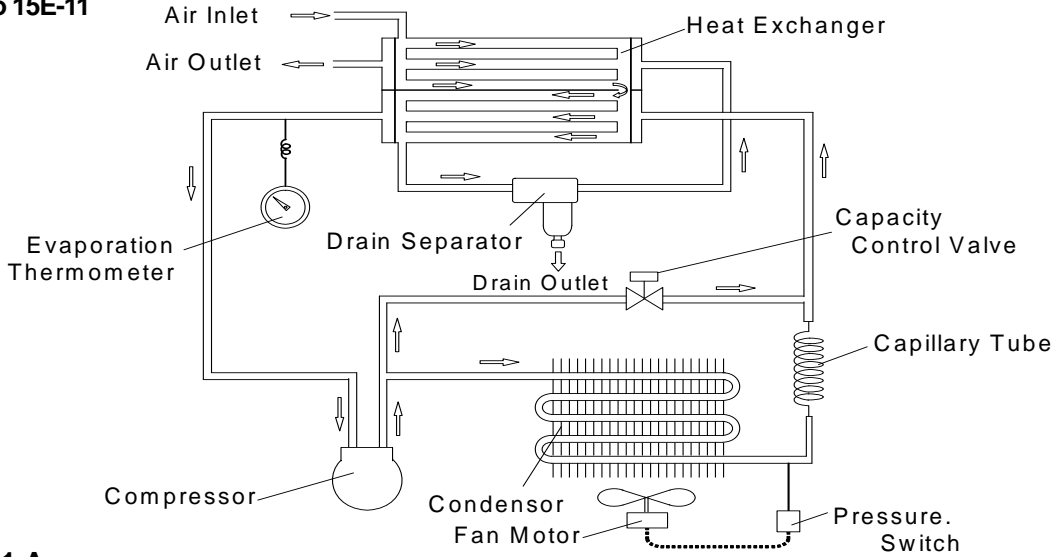

**IDFB3E-11-A**

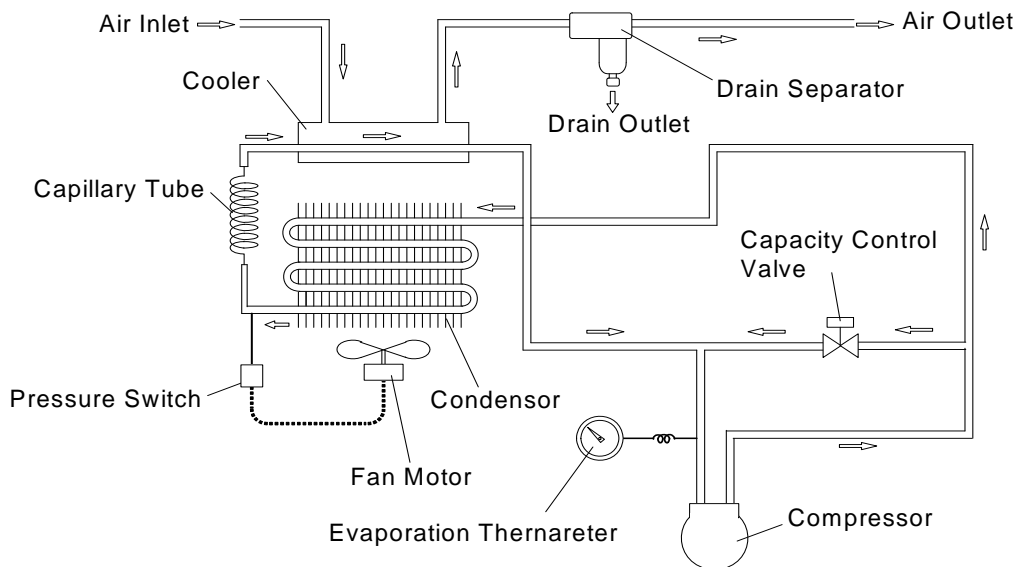

## IDFB4E to 11E-11-A

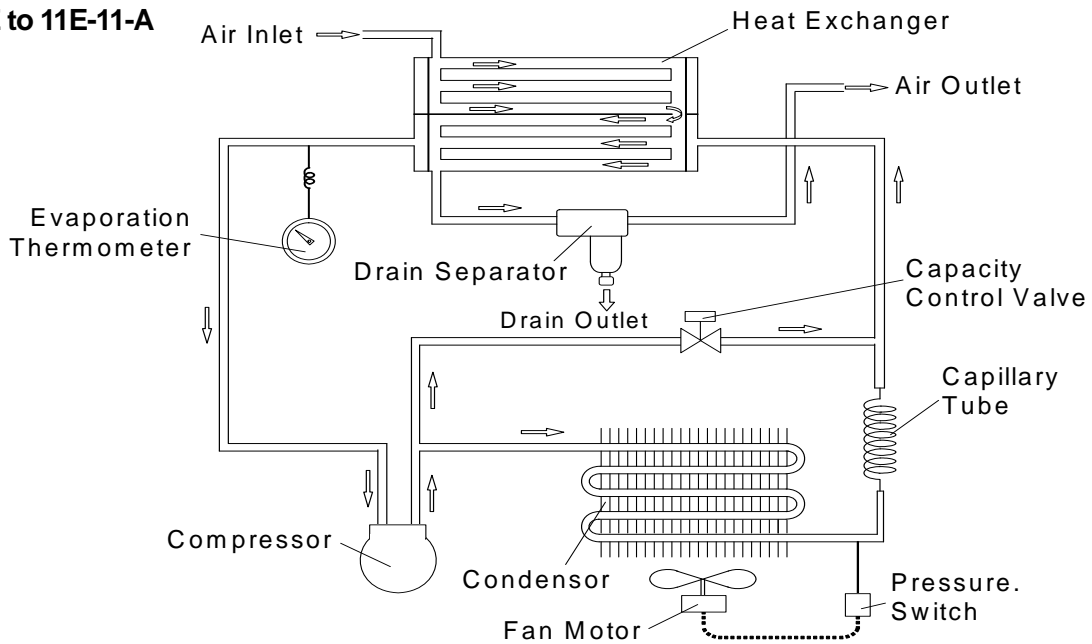
**Compressed Air Circuit**

Humid hot air entering air dryer is cooled in the cooler. At this time, the condensate is separated from the air by the drain separator and automatically discharged. The dry air is heated by the reheater until it gets about the same temperature as that of ambient air. It is then discharged from air dryer outlet.

**Refrigerant Circuit**

The Fluorocarbon charged in the refrigerant circuit is compressed by the compressor and cooled by the condenser to become liquid. Then, going through the capillary tube, the refrigerant pressure and temperature (evaporating temperature) decreased rapidly. Passing through the cooler part, it draws heat from the hot compressed air and intensely boils. Finally, it is sucked into the compressor again. The hot gas bypass valve opens to prevent compressor from freezing when compressed air is too cold.



## 7 Specification for Option A

### 7-1 Safety instructions

When handling the product, take care to the following precautions.



### Warning

Shut off the power supply when removing the panel for maintenance work, etc. The product has a fan(s) and could cause serious danger to operators.

### 7-2 Specification

The specification for this air dryer is used for cooling down the compressed air. The compressed air comes out after cooled down and dehumidified without reheating. Remind that the air flow capacity is less than the standard models.

### 7-3 Air piping

Since cool air comes out from an outlet of air dryers, carefully attach thermal insulation to the piping at air outlet and keep the piping length as short as possible in order to prevent condensation on the outlet piping and temperature increase on the outlet due to ambient temperature.

### 7-4 Dryer specifications

Models	IDFB3E	IDFB4E	IDFB6E	IDFB8E	IDFB11E
Air flow rate (ANR)	5SCFM (8 m <sup>3</sup> /h)	13SCFM (23 m <sup>3</sup> /h)	17SCFM (29 m <sup>3</sup> /h)	19SCFM (32 m <sup>3</sup> /h)	23SCFM (39 m <sup>3</sup> /h)
Outlet air temp.	50° F (10°C)				

- The data for ANR is referring to the conditions of 68° F (20°C), 1atm. pressure & relative humidity of 65%.
- This air dryer for cooling compressed air indicates temperature, while the standard product indicates dew point of outlet air pressure.
- The conditions are the same as the ones for standard models other than air flow capacity.



## Specification for Option K

### • 8-1 Safety instructions

When handling the product, take care of the following precautions.

#### Warning

1. Do not remove the auto drain if air pressure remains in the product. When removing the auto drain, stop the supply of air to the primary side of the product, exhaust the air from the secondary side and ensure there is no residual pressure. If the air pressure is left inside of the product, parts could suddenly pop out and cause accident when loosened.
2. Put gloves to prevent injury when removing the auto drain.
3. Operator could touch the drain waste from repalced auto drain. Follow the procedures prepared by the customer to ensure the safety of the operators. (Ex. Put protective goggles, apron and/or gloves to protect body from toucing the drain waste when performing maintance on the product.)

### • 8-2 Specifications

The auto drain has a maximum operating pressure of 1.6MPa and uses the metal case with a fluid level indicator.

#### IDFB6E to 15E

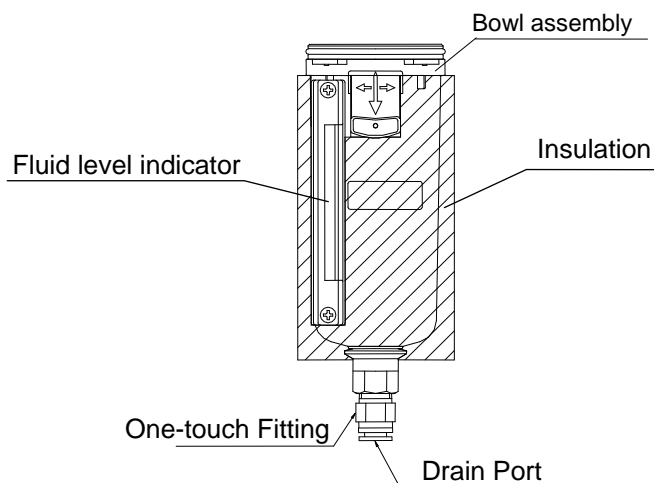

Item	Model	IDFB6E to 15E-11-K
Operating pressure		0.15 to 1.6MPa
Auto drain type		Floating type
Auto drain valve type		N.O. (normally opened: Released without pressurization)

**Auto drain product number for replacement**

Product number	Product name	QTY	Applicable model	Remarks
AD48-8-A-X2112	Bowl assembly	1	IDFB6E~15E-**-K	With bowl packing
AD48N-8Z-A-X2112		1	IDFB6E~15E-**-N-K	
KQ2H10-02AS	One-touch Fitting	1	IDFB6E~15E-**-K	$\phi$ 10×R1/4
KQ2H11-35AS		1	IDFB6E~15E-**-N-K	$\phi$ 3/8×NPT1/4
IDF-S1926	Bowl assembly insulator	1	-	-

**Auto drain Parts**

Product number	Product name	QTY
IDF-S0002	Auto drain strainer	1
C42FP-260S	Bowl packing	1

**Case thermal insulator product number for replacement**

Product number	Product name	QTY
IDF-S0529	Case thermal insulator	1



# 9 Specification for Option R

This product mounts the Ground Fault Circuit Interrupter (GFCI) in Item 2. It will shut off the power supply in case the product should have over current or current leakage. Additionally, the power supply should be connected directly to the primary side of the GFCI. For the details of the GFCI such as the specifications and mounting position, refer to Item 2 or later.

## 9-1 Safety instructions

When handling the product, take care to the following precautions.



### Warning

**Only qualified person must perform wiring and observing the following points.**

1. Be sure to shut off the power supply before wiring. For safety, do not perform any work on the unit with the power supply on. The power supply cannot be completely shut off just by turning off the illuminated switch. Be sure to turn off all power lines connected to the product.
2. Supply the power from a stable source, free from surges.
3. Provide the power suitable for the product specifications.
4. Be sure to ground the product for the safety. Without grounding, the GFCI can not operate normally.
5. Do not ground to water pipe, gas tube or lightning rod line.
6. Do not connect too many wires to the same outlet, which could results in heat generation and fire.
7. Do not retrofit the wiring of the dryer and the power supply line.

## 9-2 Specifications of the GFCI

Dryer model number	Specifications of GFCI
IDFB4E to 15E-11□-R	Rated current: 15A, Current sensitivity: 30mA

## 9-3 Cautions for handling the GFCI

- 1) When the breaker is tripped, cut off the power supply and contact the nearest sales distributor or SMC sales.
  - With the Ground fault display button (white) released → Current leakage
  - With the Ground fault display button (white) pressed → Over current
- 2) Check the operation once a month by pressing the test button (gray) with the breaker on and Switch with Lamp off

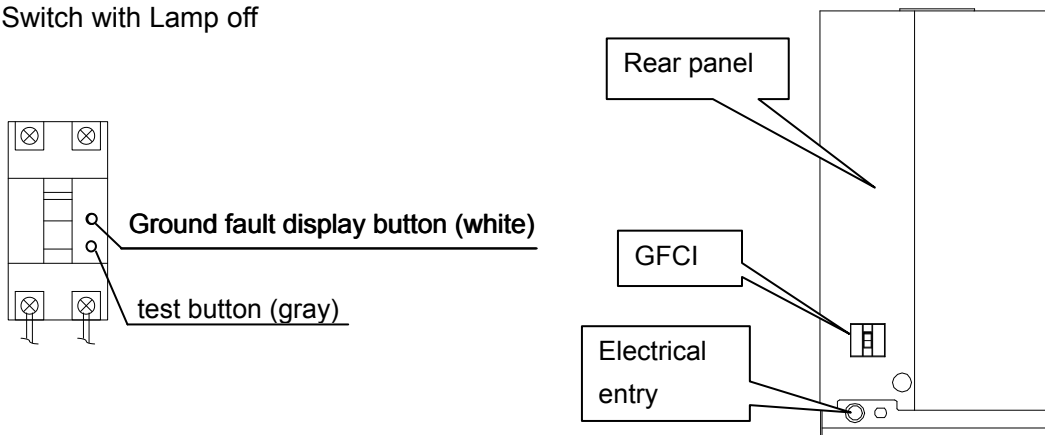



## Specification for Option S

### 10-1 Safety instructions

When handling the product, take care to the following precautions.



### Warning

**Only qualified persons are allowed to wire the product.**

1. Before wiring, be sure to shut off the power supply. Never perform wiring work while the product is energized.
2. Ensure a stable power supply with no voltage surges.
3. Use a power supply suitable for the specifications of the product.
4. Be sure to connect the ground connection.
5. Grounding should never be connected to a water line, gas line or lightning rod.
6. Multiple wiring is dangerous because it may lead to heat generation and cause a fire.
7. Do not modify the electrical wiring of the power supply.

### 10-2 Specifications

The option allows the connection of a power cable to a terminal block.

#### IDFB3E

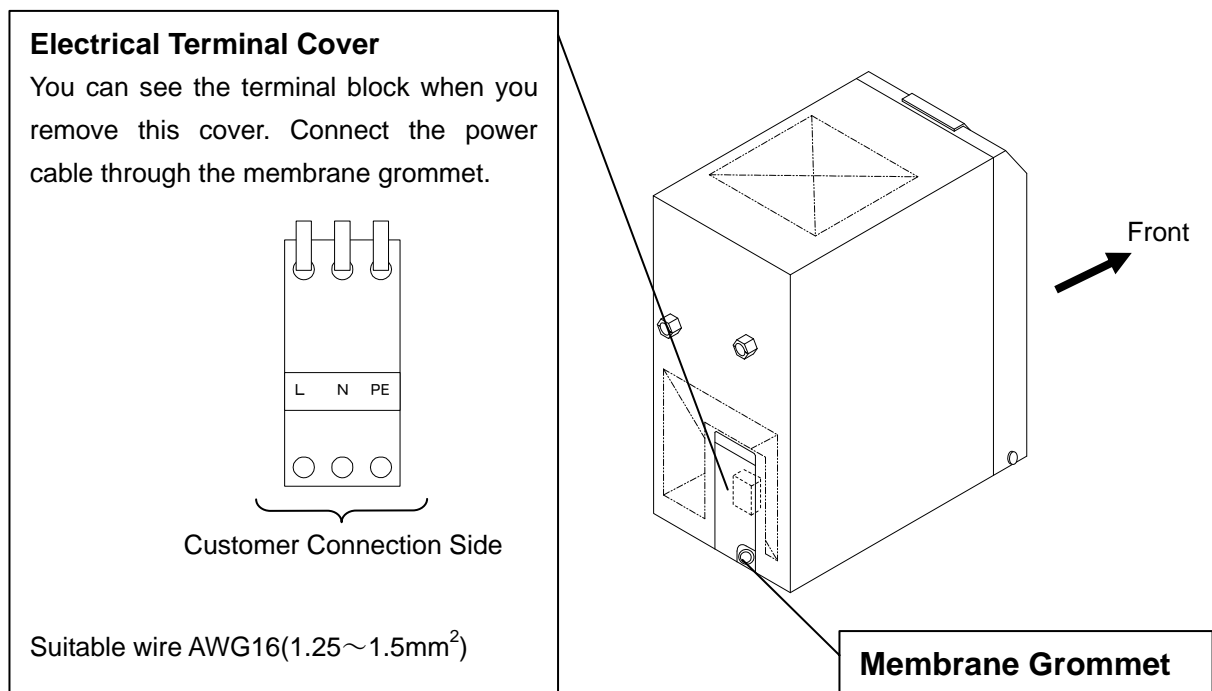

• IDFB4E to 11E

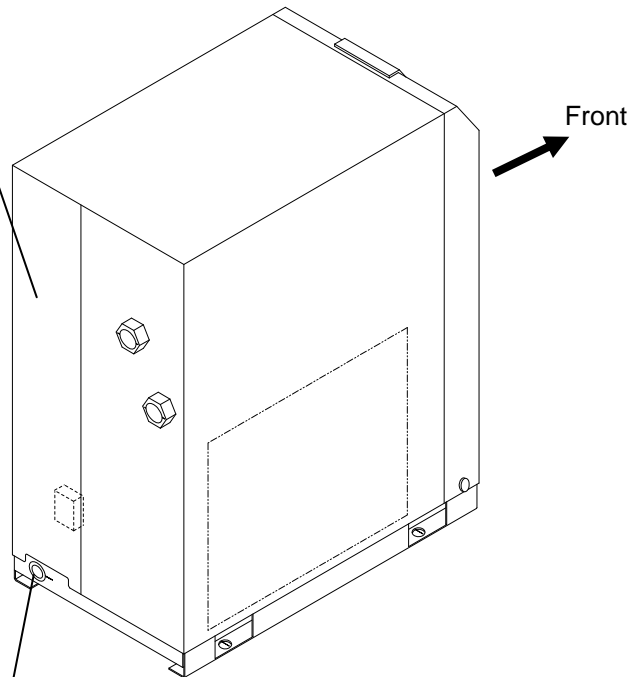
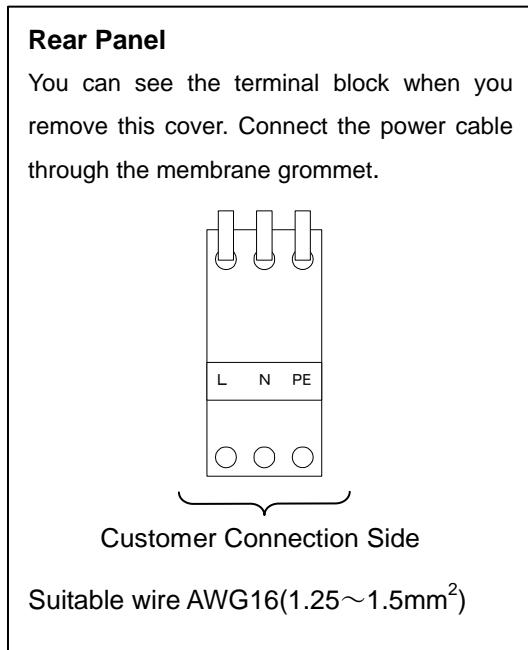

**Membrane Grommet**

• IDFB15E

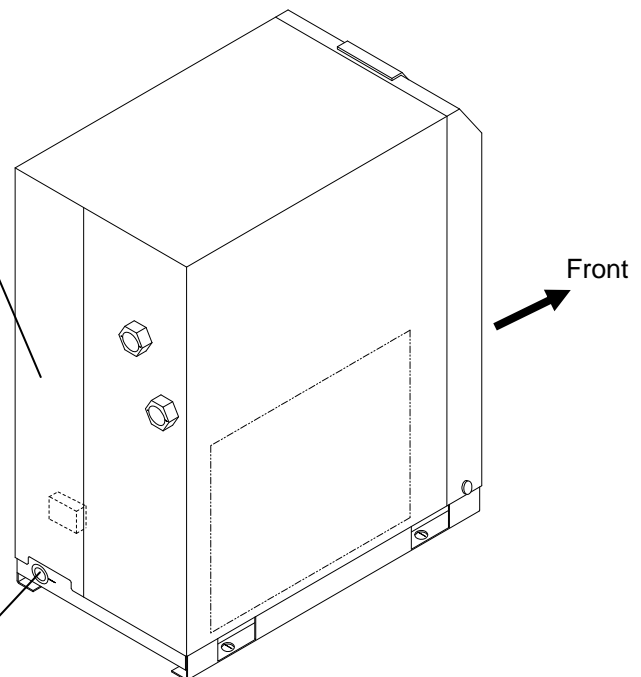
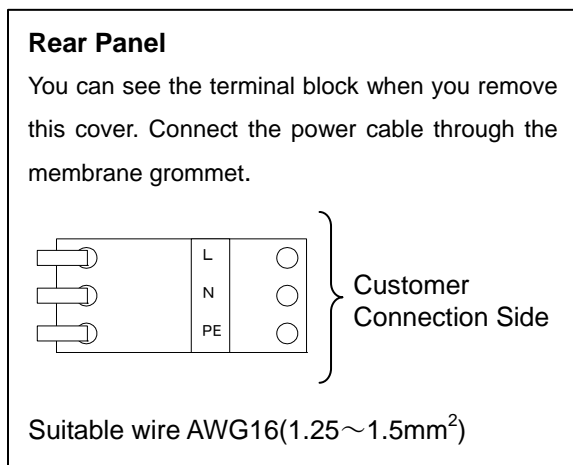

**Membrane Grommet**



## Specification for Option T

This product mounts the terminal block which can transfer the operation and failure signals to Item 2 Specifications. The signals are a no voltage contact style. For details, refer to Item 2 or later.

### **11-1 Safety instructions**

When handling the product, take care to the following precautions.



### **Warning**

**Only qualified person must perform wiring and observing the following points.**

1. Be sure to shut off the power supply before wiring. For safety, do not perform any work on the unit with the power supply on. The power supply cannot be completely shut off just by turning off the illuminated switch. Be sure to turn off all power lines connected to the product.
2. Supply the power from a stable source, free from surges.
3. Be sure to mount the Ground Fault Circuit Interrupter (GFCI) with adequate sensitivity and load capacity to prevent electrical shock and protect the refrigerating compressor motor from burning out.
4. Provide the power suitable for the product specifications.
5. Be sure to ground the product for the safety. Without grounding, the GFCI can not operate normally.
6. Do not ground to water pipe, gas tube or lightening rod line.
7. Do not connect too many wires to the same outlet, which could results in heat generation and fire.
8. Do not retrofit the wiring of the dryer and the power supply line.
9. For the use of the product in Europe, mount the breaker compatible to IEC standard to the power supply for the product.

### **11-2 Specifications**

The product mounts the terminal block which can transfer the operation and failure signals on the standard product.

- The operation and failure signals are no voltage contact style.
  - Operation · · · · When the product is operating; Close
  - Failure · · · · When the product stops due to failure; Close
- Contact capacity
  - AC200V/2A
  - DC24V/2A
  - (Minimum applicable load: 20V / 3mA)

**11-3 Remote operation**

- For the remote operation, turn on and off the power supply side under the condition of the Switch with Lamp ON.
  - Keep 3 min. at minimum after stopping the product to restart even for the remote operation. If the product is restarted within less than 3 min., protective equipment (overload relay) may activate and prevent the product from restarting.
- Additionally, the frequency to start and stop the operation must be restricted to 5 times per hour (to prevent breakage of the motor).

**11-4 How to connect the power supply and signal cable**

Connect the power cable and signal cable in the following procedures.

- 1) Take off the front panel.
- 2) Insert the power cable prepared by the customer into the power code inlet (with rubber grommet) and bring the power cable near the terminal block through the base hole.
- 3) Connect the power cable to the terminal.
- 4) Insert the signal cable prepared by the customer into the signal code inlet (with rubber grommet) and bring the signal cable near the terminal block.
- 5) Connect the signal cable to the each terminal.
- 6) Put back the front panel.

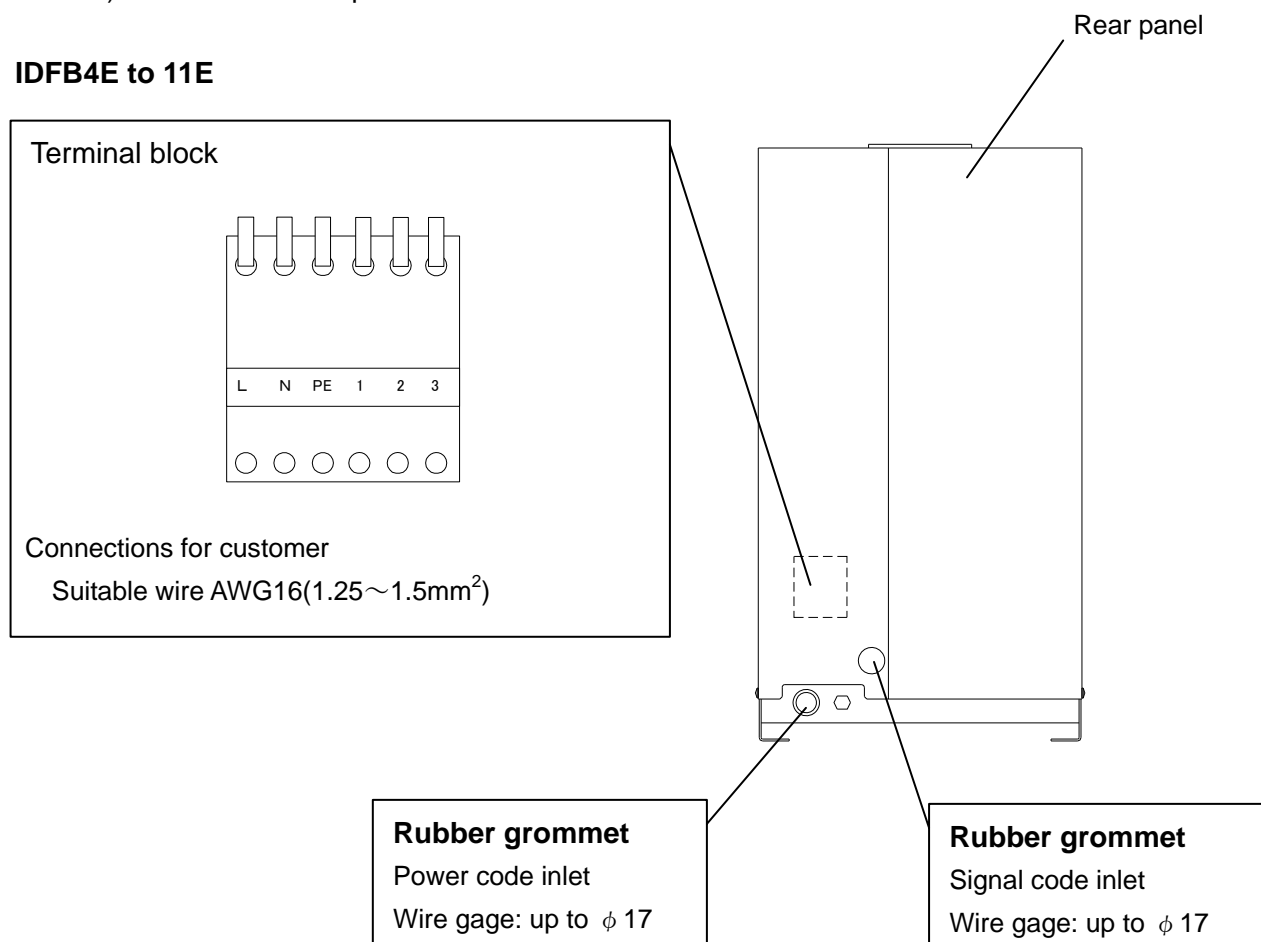
**IDFB4E to 11E**

**IDFB15E**

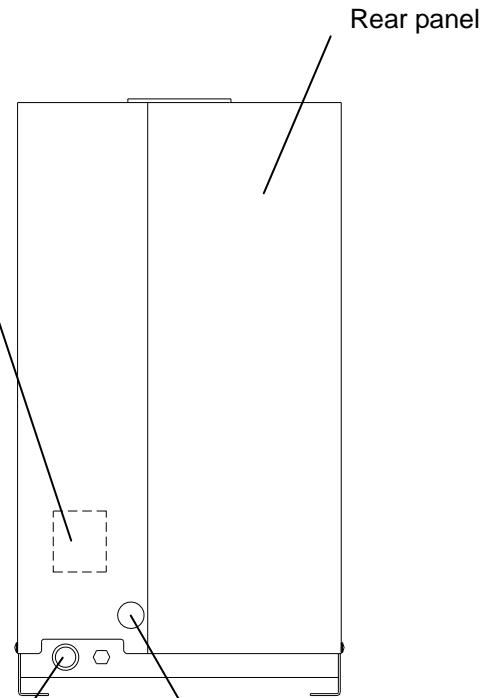
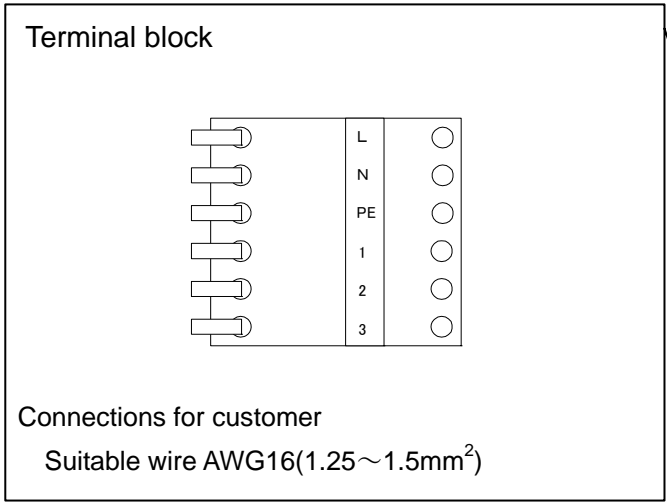

**Rubber grommet**  
Power code inlet  
Wire gage: up to  $\phi$  17

**Rubber grommet**  
Signal code inlet  
Wire gage: up to  $\phi$  17

**11-5 Electric wiring diagram**

**IDFB4E to 11E-11□-T**

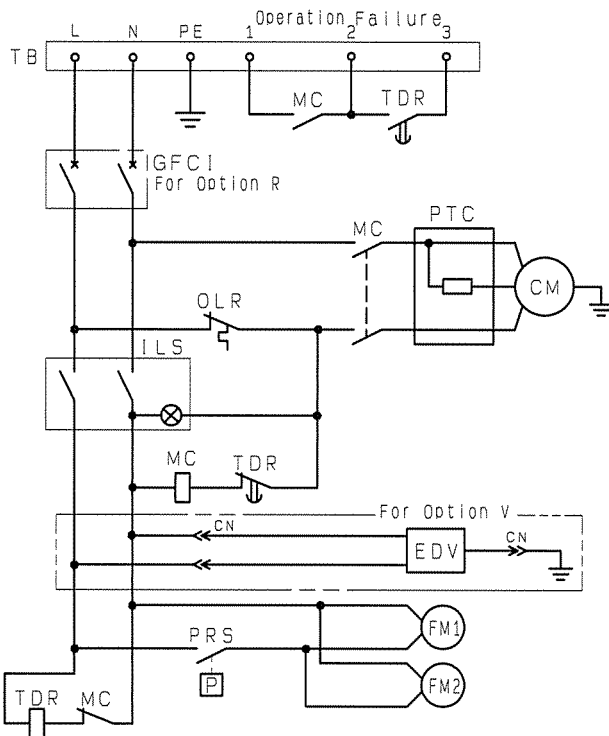

SYMBOL	DESCRIPTION
CM	Compressor Motor
FM1,2	Fan Motor
OLR	Overload Relay
ILS	Switch with Lamp
PRS	Pressure Switch
PTC	PTC Starter
TB	Terminal Block
MC	Magnetic Contactor
TDR	Time Delay Relay
GFCI	Ground Fault Circuit Interrupter
EDV	Electronic Drain Valve

IDFB15E-11□-T

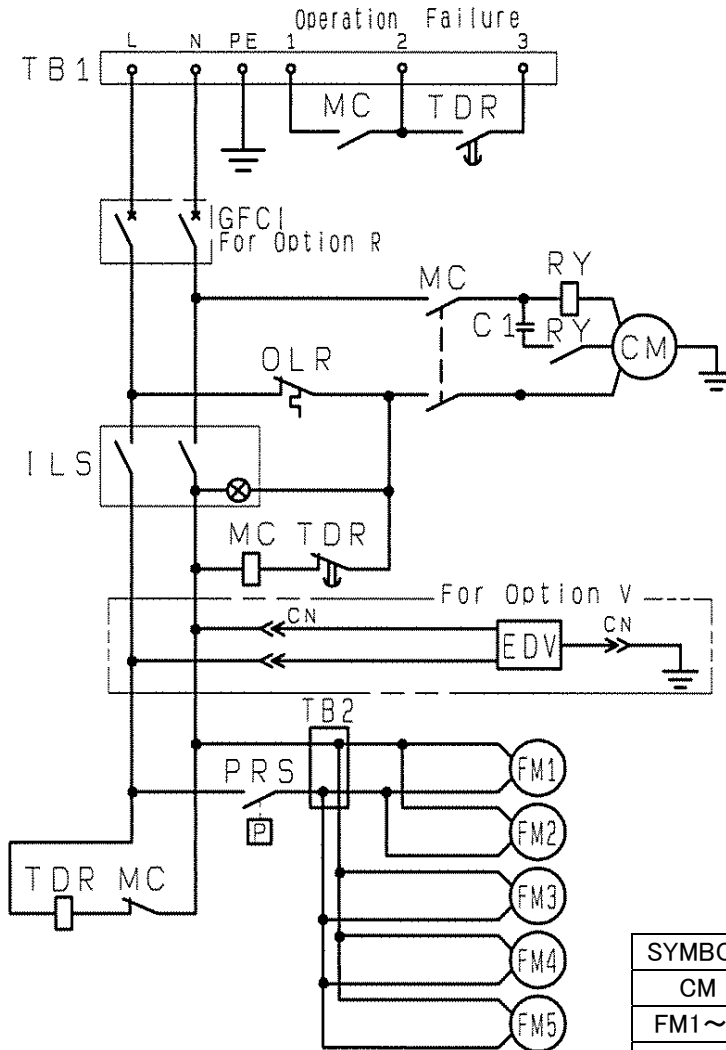

SYMBOL	DESCRIPTION
CM	Compressor Motor
FM1~5	Fan Motor
OLR	Overload Relay
C1	Capacitor For Compressor Motor
ILS	Switch with Lamp
PRS	Pressure Switch
PTC	PTC Starter
TB1~2	Terminal Block
MC	Magnetic Contactor
RY	Starting Relay
TDR	Time Delay Relay
GFCI	Ground Fault Circuit Interrupter
EDV	Electronic Drain Valve



## Specification for Option V

This product mounts the timer operated auto drain in Item 2 Specifications. When performing the installation and maintenance work for the product, the following points must be understood and followed. Additionally, read Item 3 for replacement work.

### **12-1** **Safety instructions**

When handling the product, take care to the following precautions.

#### **Warning**

1. Do not remove the auto drain if air pressure remains of the product. When removing the auto drain, stop the supply of air to the primary side of the product, exhaust the air from the secondary side and ensure there is no residual pressure. If the air pressure is left at the inside of the product, parts could suddenly pop out and cause accident when loosened.
2. Put gloves to prevent injury when removing the auto drain.
3. Operator could touch the drain waste from repalced auto drain. Follow the procedures prepared by the customer to keep safety of operators. (Ex. Put protective goggles, apron and/or gloves to protect body from toucing the drain waste for replacement worken replacing the product.)

#### **Warning**

**Only qualified person must perform wiring.**

1. Provide the power suitable for the product specifications.
2. Be suer to ground the product for the safety. Do not ground to water pipe, gas tube or lightening rod line.
3. Do not connect too many wires to the same outlet, which could results in heat generation and fire.
4. Do not retrofit the wiring of the dryer and the power supply line.

### **12-2** **Specifications**

The timer is set to have ON time of 0.5sec and OFF time of 0.5min. at the time of shipment from the factory. Do not change this timer setting. If it is changed, water could be discharged from the outlet line of the dryer. Service parts number will change depending on the power supply voltage of the dryer.



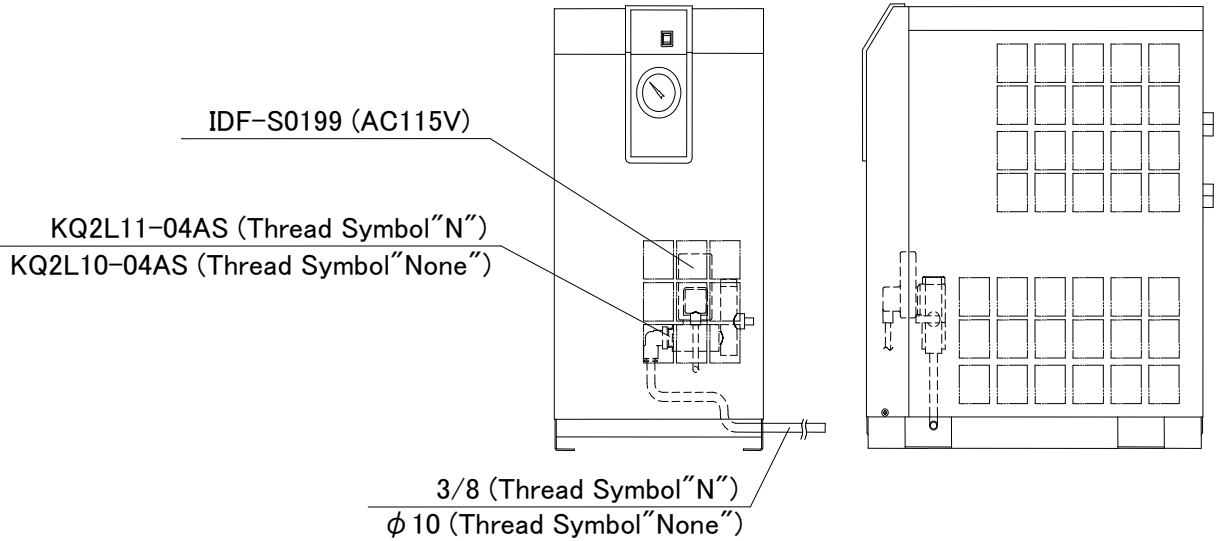

Model	IDFB4E~15E-11*-V
Order number (service parts)	IDF-S0199
Max. operating pressure	240psig (1.6MPa)
Fluid	Drain
Power supply voltage of drain timer	AC115V±10% (60Hz)
ON time	0.5sec
OFF time	0.5min

### 12-3 How to perform maintenance

The product needs to be maintained. Clean it in the following procedure periodically.

- 1) Close the ball valve.
- 2) Press the test switch and make the residual pressure zero.
- 3) Remove the strainer and clean it.
- 4) Reassemble the strainer and open the ball valve.

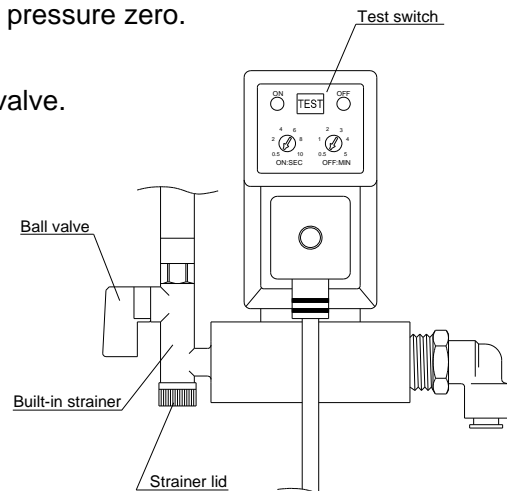

**13** **Service Record**

**13-1** **Service Record**

It is recommended to keep a maintenance/service record.

Parts No.	Description	Maintenance/Service Work Description	Date

Revision
Rev. B : Jan. 2020

## SMC Corporation

Akihabara UDX 15F,  
4-14-1, Sotokanda, Chiyoda-ku, Tokyo 101-0021, JAPAN  
Tel: +81 3 5207 8249 Fax: +81 3 5298 5362  
URL: <http://www.smcworld.com>

Specifications are subject to change without prior notice and any obligation the part of the manufacturer.  
© 2019 SMC Corporation All Rights Reserved

