



# Operation Manual

## PRODUCT NAME

Fieldbus system  
CC-Link IE Field compatible SI Unit  
IO-Link Master Unit

## MODEL / Series / Product Number

*EX600-SCF1-X60*  
*EX600-GILB-X60*  
*EX600-ED#*

**SMC Corporation**

## Table of Contents

Safety Instructions	2
System Outline	8
Assembly	9
Mounting and Installation	11
<b>SI Unit</b>	
Model Indication and How to Order	13
Summary of Product parts	13
Mounting and Installation	14
Setting and Adjustment	14
LED Display	16
Specification	18
<b>IO-Link Master Unit</b>	
Model Indication and How to Order	20
Summary of Product parts	20
Mounting and Installation	21
LED Display	21
Specification	24
<b>End Plate</b>	
Model Indication and How to Order	26
Summary of Product parts	26
Mounting and Installation	27
Specification	28
<b>I/O Map</b>	30
<b>Parameter Setting</b>	39
<b>Parameter setting with network parameter window</b>	53
Parameter setting of EX600	53
Parameter setting of IO-Link Device	58
<b>Parameter Setting with acyclic transmission</b>	65
Parameter setting of EX600	66
Parameter setting of IO-Link Device	77
<b>Accessories</b>	80



# Safety Instructions

These safety instructions are intended to prevent hazardous situations and/or equipment damage. These instructions indicate the level of potential hazard with the labels of "Caution", "Warning" or "Danger". They are all important notes for safety and must be followed in addition to International Standards (ISO/IEC)\*1), and other safety regulations.

\*1) ISO 4414: Pneumatic fluid power -- General rules relating to systems.

ISO 4413: Hydraulic fluid power -- General rules relating to systems.

IEC 60204-1: Safety of machinery -- Electrical equipment of machines. (Part 1: General requirements)

ISO 10218: Manipulating industrial robots -Safety.

etc.



## Caution

**Caution** indicates a hazard with a low level of risk which, if not avoided, could result in minor or moderate injury.



## Warning

**Warning** indicates a hazard with a medium level of risk which, if not avoided, could result in death or serious injury.



## Danger

**Danger** indicates a hazard with a high level of risk which, if not avoided, will result in death or serious injury.

## Warning

### 1. The compatibility of the product is the responsibility of the person who designs the equipment or decides its specifications.

Since the product specified here is used under various operating conditions, its compatibility with specific equipment must be decided by the person who designs the equipment or decides its specifications based on necessary analysis and test results.

The expected performance and safety assurance of the equipment will be the responsibility of the person who has determined its compatibility with the product.

This person should also continuously review all specifications of the product referring to its latest catalog information, with a view to giving due consideration to any possibility of equipment failure when configuring the equipment.

### 2. Only personnel with appropriate training should operate machinery and equipment.

The product specified here may become unsafe if handled incorrectly.

The assembly, operation and maintenance of machines or equipment including our products must be performed by an operator who is appropriately trained and experienced.

### 3. Do not service or attempt to remove product and machinery/equipment until safety is confirmed.

1. The inspection and maintenance of machinery/equipment should only be performed after measures to prevent falling or runaway of the driven objects have been confirmed.

2. When the product is to be removed, confirm that the safety measures as mentioned above are implemented and the power from any appropriate source is cut, and read and understand the specific product precautions of all relevant products carefully.

3. Before machinery/equipment is restarted, take measures to prevent unexpected operation and malfunction.

### 4. Contact SMC beforehand and take special consideration of safety measures if the product is to be used in any of the following conditions.

1. Conditions and environments outside of the given specifications, or use outdoors or in a place exposed to direct sunlight.

2. Installation on equipment in conjunction with atomic energy, railways, air navigation, space, shipping, vehicles, military, medical treatment, combustion and recreation, or equipment in contact with food and beverages, emergency stop circuits, clutch and brake circuits in press applications, safety equipment or other applications unsuitable for the standard specifications described in the product catalog.

3. An application which could have negative effects on people, property, or animals requiring special safety analysis.

4. Use in an interlock circuit, which requires the provision of double interlock for possible failure by using a mechanical protective function, and periodical checks to confirm proper operation.



# Safety Instructions

## Caution

### **1. The product is provided for use in manufacturing industries.**

The product herein described is basically provided for peaceful use in manufacturing industries. If considering using the product in other industries, consult SMC beforehand and exchange specifications or a contract if necessary.  
If anything is unclear, contact your nearest sales branch.

## **Limited warranty and Disclaimer/Compliance Requirements**

The product used is subject to the following "Limited warranty and Disclaimer" and "Compliance Requirements".

Read and accept them before using the product.

### **Limited warranty and Disclaimer**

**1. The warranty period of the product is 1 year in service or 1.5 years after the product is delivered, whichever is first.\*2)**

**Also, the product may have specified durability, running distance or replacement parts. Please consult your nearest sales branch.**

**2. For any failure or damage reported within the warranty period which is clearly our responsibility, a replacement product or necessary parts will be provided.**

**This limited warranty applies only to our product independently, and not to any other damage incurred due to the failure of the product.**

**3. Prior to using SMC products, please read and understand the warranty terms and disclaimers noted in the specified catalog for the particular products.**

**\*2) Vacuum pads are excluded from this 1 year warranty.**

**A vacuum pad is a consumable part, so it is warranted for a year after it is delivered.**

**Also, even within the warranty period, the wear of a product due to the use of the vacuum pad or failure due to the deterioration of rubber material are not covered by the limited warranty.**

### **Compliance Requirements**

**1. The use of SMC products with production equipment for the manufacture of weapons of mass destruction (WMD) or any other weapon is strictly prohibited.**

**2. The exports of SMC products or technology from one country to another are governed by the relevant security laws and regulation of the countries involved in the transaction. Prior to the shipment of a SMC product to another country, assure that all local rules governing that export are known and followed.**

## Operator

- ◆ This operation manual is intended for those who have knowledge of machinery using pneumatic equipment, and have sufficient knowledge of assembly, operation and maintenance of such equipment. Only those persons are allowed to perform assembly, operation and maintenance.
- ◆ Read and understand this operation manual carefully before assembling, operating or providing maintenance to the product.

### ■ Safety Instructions

#### Warning

- Do not disassemble, modify (including changing the printed circuit board) or repair.  
An injury or failure can result.
- Do not operate or set with wet hands.  
This may lead to an electric shock.
- Do not operate the product outside of the specifications.  
Do not use for flammable or harmful fluids.  
Fire, malfunction, or damage to the product can result.  
Verify the specifications before use.
- Do not operate in an atmosphere containing flammable or explosive gases.  
Fire or an explosion can result.  
This product is not designed to be explosion proof.
- If using the product in an interlocking circuit:
  - Provide a double interlocking system, for example a mechanical system.
  - Check the product regularly for proper operation.Otherwise malfunction can result, causing an accident.
- The following instructions must be followed during maintenance:
  - Turn off the power supply.
  - Stop the air supply, exhaust the residual pressure and verify that the air is released before performing maintenance.Otherwise an injury can result.

## **Caution**

- When handling the unit or assembling/replacing units:
  - Do not touch the sharp metal parts of the connector or plug for connecting units.
  - Take care not to hit your hand when disassembling the unit.  
The connecting portions of the unit are firmly joined with seals.
  - When joining units, take care not to get fingers caught between units.  
An injury can result.
- After maintenance is complete, perform appropriate functional inspections.  
Stop operation if the equipment does not function properly.  
Safety cannot be assured in the case of unexpected malfunction.
- Provide grounding to assure the safety and noise resistance of the Fieldbus system.  
Individual grounding should be provided close to the product with a short cable.

## ■ **NOTE**

- Follow the instructions given below when designing, selecting and handling the product.
  - The instructions on design and selection (installation, wiring, environment, adjustment, operation, maintenance, etc.) described below must also be followed.
    - \*Product specifications
      - The direct current power supply to combine should be UL1310 Class 2 power supply when conformity to UL is necessary.
      - Use the specified voltage.  
Otherwise failure or malfunction can result.
      - Reserve a space for maintenance.  
Allow sufficient space for maintenance when designing the system.
      - Do not remove any nameplates or labels.  
This can lead to incorrect maintenance, or misreading of the operation manual, which could cause damage or malfunction to the product.  
It may also result in non-conformity to safety standards.
      - Beware of inrush current when the power supply is turned on.  
Some connected loads can apply an initial charge current which will activate the over current protection function, causing the unit to malfunction.

## ● Product handling

### \*Installation

- Do not drop, hit or apply excessive shock to the SI unit.

Otherwise damage to the product can result, causing malfunction.

- Tighten to the specified tightening torque.

If the tightening torque is exceeded the mounting screws may be broken.

IP67 protection cannot be guaranteed if the screws are not tightened to the specified torque.

- If a large manifold valve is mounted, lift the unit so that stress is not applied to the connecting part while transporting.

The stress may cause breakage of the connecting part. The unit may become very heavy depending on the combination. Transportation/installation shall be performed by multiple operators.

- Never mount a product in a location that will be used as a foothold.

The product may be damaged if excessive force is applied by stepping or climbing onto it.

### \*Wiring

- Avoid repeatedly bending or stretching the cables, or placing heavy load on them.

Repetitive bending stress or tensile stress can cause breakage of the cable.

- Wire correctly.

Incorrect wiring can break the product.

- Do not perform wiring while the power is on.

Otherwise damage to the SI unit and/or input or output device can result, causing malfunction.

- Do not route wires and cables together with power or high voltage cables.

Otherwise the SI unit and/or input or output device can malfunction due to interference of noise and surge voltage from power and high voltage cables to the signal line.

Route the wires (piping) of the SI unit and/or input or output device separately from power or high voltage cables.

- Confirm proper insulation of wiring.

Poor insulation (interference from another circuit, poor insulation between terminals, etc.) can lead to excess voltage or current being applied to the product, causing damage.

- Take appropriate measures against noise, such as using a noise filter, when the Fieldbus system is incorporated into equipment.

Otherwise noise can cause malfunction.

### \*Environment

- Select the proper type of protection according to the environment of operation.

IP67 protection is achieved when the following conditions are met.

- (1) The units are connected properly with fieldbus cable with M12 connector and power cable with M12 (M8) connector.

- (2) Suitable mounting of each unit and manifold valve.

- (3) Be sure to fit a waterproof cap on any unused connectors.

If using in an environment that is exposed to water splashes, please take measures such as using a cover.

Do not use in an environment where moisture or water vapor are present. Otherwise failure and malfunction can result.

- Do not use in a place where the product could be splashed by oil or chemicals.

If the product is to be used in an environment containing oils or chemicals such as coolant or cleaning solvent, even for a short time, it may be adversely affected (damage, malfunction etc.).

- Do not use the product in an environment where corrosive gases or fluids could be splashed.

Otherwise damage to the product and malfunction can result.

- Do not use in an area where surges are generated.

If there is equipment generating large surge near the unit (magnetic type lifter, high frequency inductive furnace, welding machine, motor, etc.), this can cause deterioration of the internal circuitry element of the unit or result in damage. Take measures against the surge sources, and prevent the lines from coming into close contact.

- When a surge-generating load such as a relay, valve or lamp is driven directly, use a product with a built-in surge absorbing element.  
Direct drive of a load generating surge voltage can damage the unit.
- The product is CE marked, but not immune to lightning strikes. Take measures against lightning strikes in the system.
- Prevent foreign matter such as dust or wire debris from getting inside the product.
- Mount the product in a place that is not exposed to vibration or impact.  
Otherwise failure or malfunction can result.
- Do not use the product in an environment that is exposed to temperature cycle.  
Heat cycles other than ordinary changes in temperature can adversely affect the inside of the product.
- Do not expose the product to direct sunlight.  
If using in a location directly exposed to sunlight, shade the product from the sunlight.  
Otherwise failure or malfunction can result.
- Keep within the specified ambient temperature range.  
Otherwise malfunction can result.
- Do not operate close to a heat source, or in a location exposed to radiant heat.  
Otherwise malfunction can result.

\*Adjustment and Operation

- Set the switches by using a sharp-pointed screwdriver etc. When setting the switch, do not touch other unrelated parts.  
This can cause parts damage or malfunction due to a short circuit.
- Perform settings suitable for the operating conditions.  
Incorrect setting can cause operation failure.
- Please refer to the PLC manufacturer's manual etc. for details of programming and addresses.  
For the PLC protocol and programming refer to the relevant manufacturer's documentation.

\*Maintenance

- Turn off the power supply, stop the supplied air, exhaust the residual pressure and verify the release of air before performing maintenance.  
There is a risk of unexpected malfunction.
- Perform regular maintenance and inspections.  
There is a risk of unexpected malfunction.
- After maintenance is complete, perform appropriate functional inspections.  
Stop operation if the equipment does not function properly.  
Otherwise safety is not assured due to an unexpected malfunction or incorrect operation.
- Do not use solvents such as benzene, thinner etc. to clean each unit.  
They could damage the surface of the body and erase the markings on the body.  
Use a soft cloth to remove stains.  
For heavy stains, use a cloth soaked with diluted neutral detergent and fully squeezed, then wipe up the stains again with a dry cloth.



# System Outline

## ■ System configuration

The EX600 range of units can be connected to various types of fieldbus to realize the reduction of input or output device wiring and the distributed control system. The unit communicates with the fieldbus through the SI unit. One SI unit can be connected with manifold valves with up to 32 outputs and the input • output • I/O units with maximum 10 units.

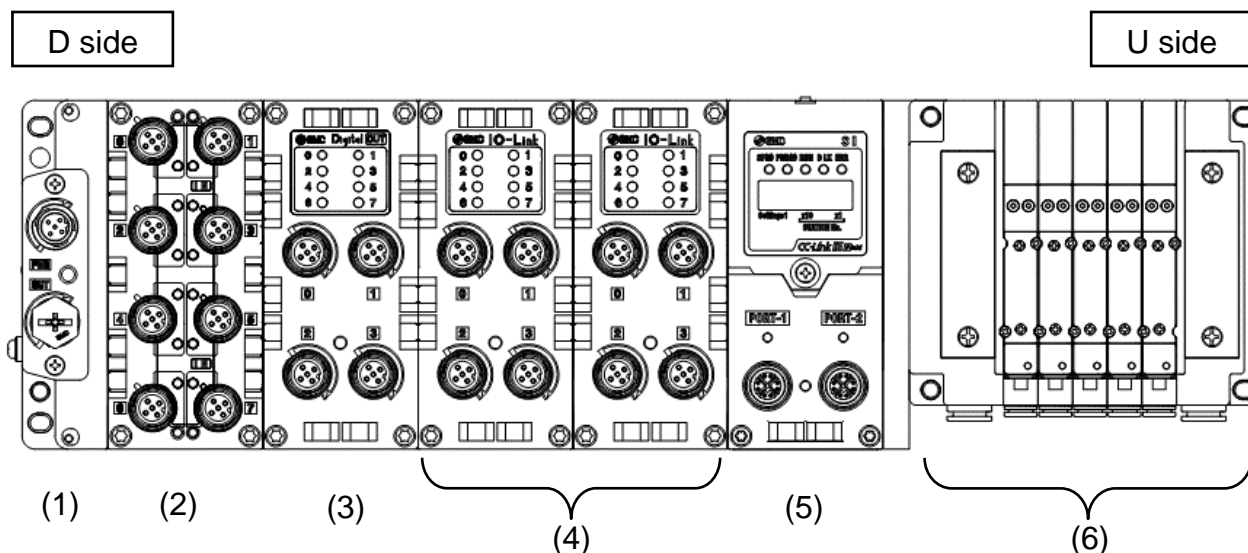

No.	Mode name	Model number	Function
1	End plate	EX600-ED2	Connected at EX600 Manifold's D side, incorporating the power supply connection.
2	Digital input unit	EX600-DX#D	For connecting sensors with switch output capability. PNP and NPN types are available.
3	Digital input unit	EX600-DY#B	For connecting output device such as solenoid valves, lamps, buzzers, etc. PNP and NPN types are available.
4	IO-Link Master unit	EX600-GILB-X60	There are 4 IO-Link ports. IO-Link devices with process data size of 32 bytes or less can be connected to each port.
5	SI unit	EX600-SCF1-X60	Performs fieldbus communication and solenoid valve manifold ON/OFF output.
6	Solenoid valve manifold	-	An assembly of solenoid valves. One connector is used as the electric connection to all connected valves.

# Assembly

## ■ Composing the unit as a manifold

\*: If the unit was purchased as a manifold, the work described in this section is not necessary.

- (1) Connect the unit to the end plate.  
The Digital unit, Analogue unit can be connected in any order.  
(Tightening torque: 1.5 to 1.6Nm)

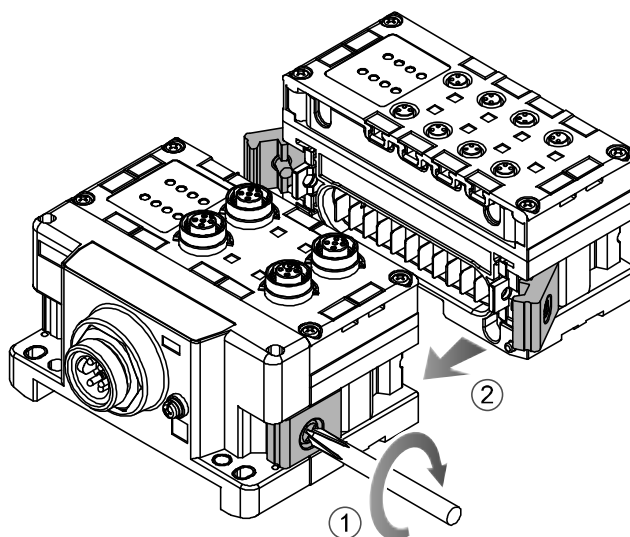

- (2) Add more units.  
Up to 10 units (including the SI unit) can be connected to one manifold.

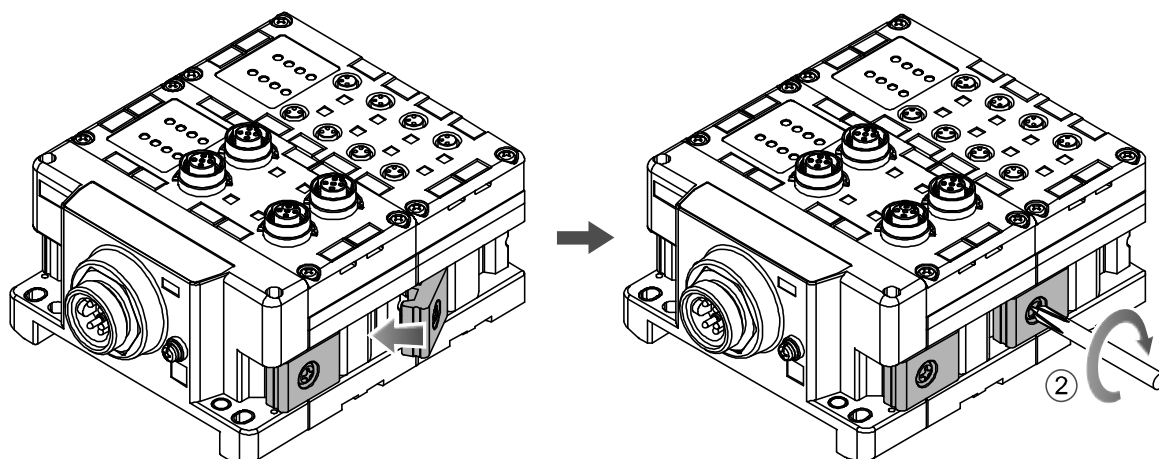

- (3) Connecting the SI unit.  
After connecting the necessary units, connect the SI unit.  
Connecting method is the same as above (1), (2).

(4) Mounting the valve plate.

Mount the valve plate (EX600-ZMV□) to the valve manifold using the valve set screws. (M3 x 8)  
(Tightening torque: 0.6 to 0.7 Nm)

Screw mounting place	
SV	: 2 places
S0700	: 2 places
VQC1000	: 2 places
VQC2000	: 3 places
VQC4000	: 4 places
SY	: 2 places

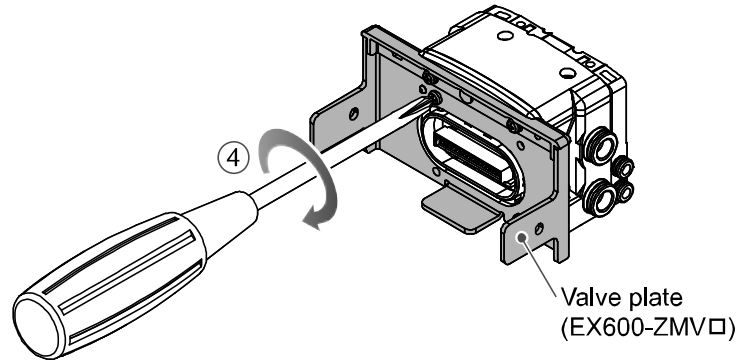

(5) Connect the SI unit and the valve manifold.

Insert the valve plate to the valve plate set groove on the side of SI unit.  
Then, tighten it with the valve plate set screws (M4 x 6) to fix the plate.  
(Tightening torque: 0.7 to 0.8 Nm)

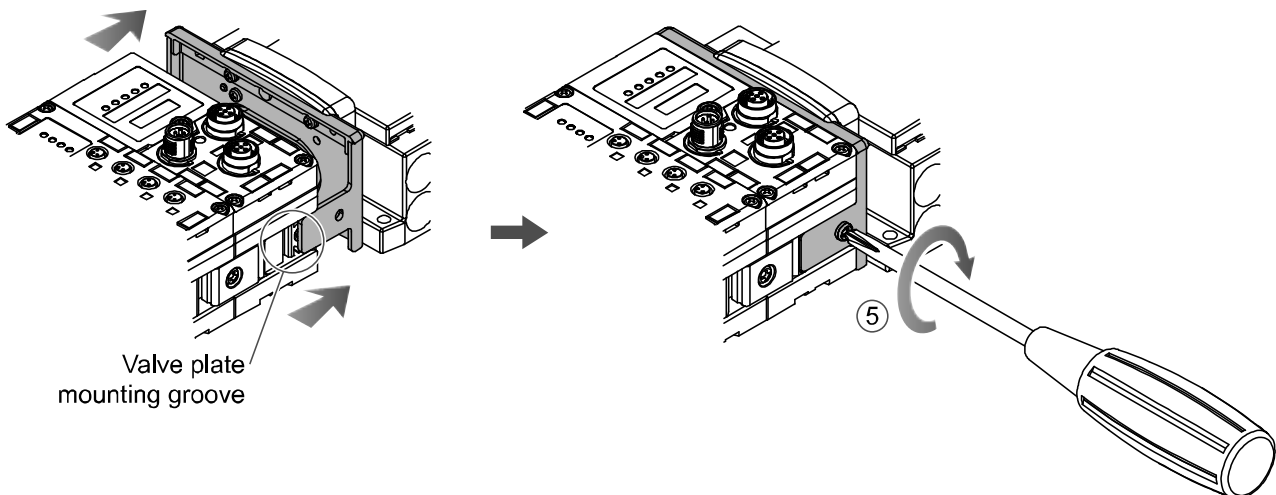

● Precautions for handling

- Please do not connect the unit while the power supply is active. It will cause equipment damage.
- Take care not to drop the nuts of Joint bracket.
- Tighten the screws to the specified torque.  
Insufficient tightening may lead to equipment malfunction, injury or equipment damage.

# Mounting and Installation

## ■ Installation

### • Direct mounting

#### (1) Direct mounting

When joining six or more units, fix the middle part of the complete EX600 unit with an intermediate reinforcing brace (EX600-ZMB1) before mounting using 2-M4 x 5 screws.

(Tightening torque: 0.7 to 0.8 Nm)

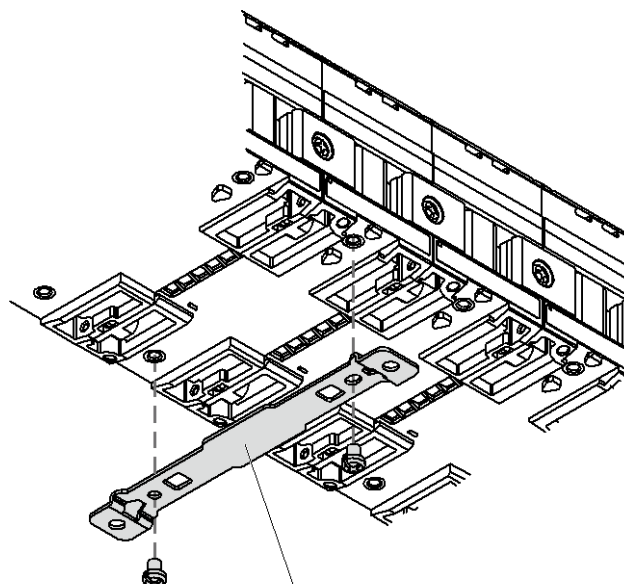

Intermediate reinforcing brace  
(EX600-ZMB1)

#### (2) Fix and tighten the end plates at one end of the unit. (M4)

(Tightening torque: 0.7 to 0.8 Nm)

Fix the end plate at the valve side while referring to the operation manual of the corresponding valve manifold.

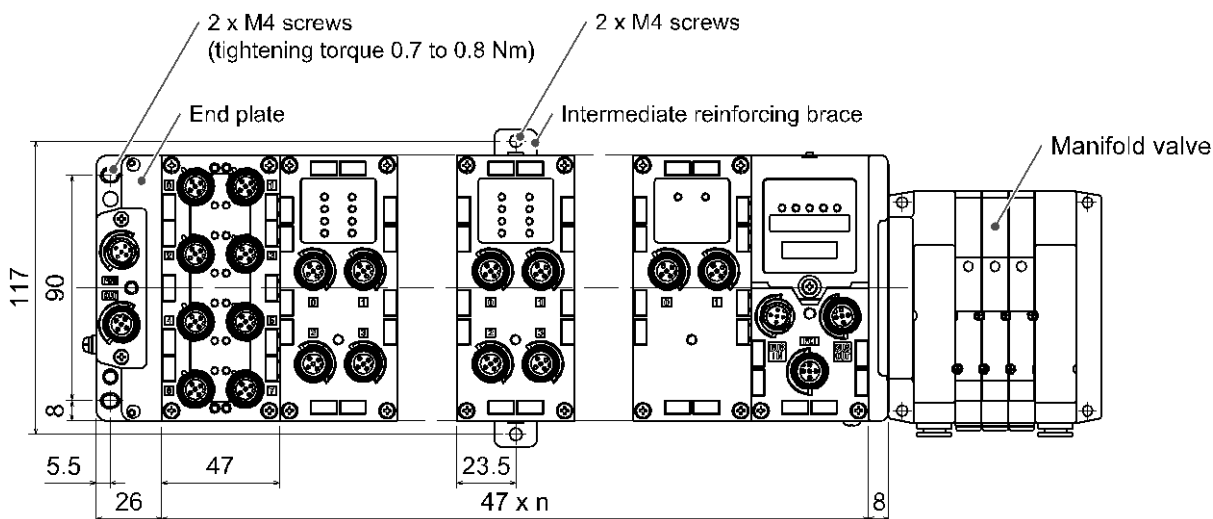

n (Number of connected Units) ≤ 10

### • Precautions for handling

- When joining six or more units, fix the middle part of the complete unit with an intermediate reinforcing brace to prevent incorrect connection between the units due to deflection.

### •DIN rail mounting

(Not available for SY series valves. Refer to the SY catalog.)

- (1) When joining six or more units, fix the middle part of the complete EX600 unit with an intermediate reinforcing brace (EX600-ZMB2) before mounting, using 2-M4 x 6 screws. (Tightening torque: 0.7 to 0.8 Nm)
- (2) Mount the end plate bracket (EX600-ZMA2) to the end plate at the opposite end to the valves, using 2-M4 x 14 screws. (Tightening torque: 0.7 to 0.8 Nm)

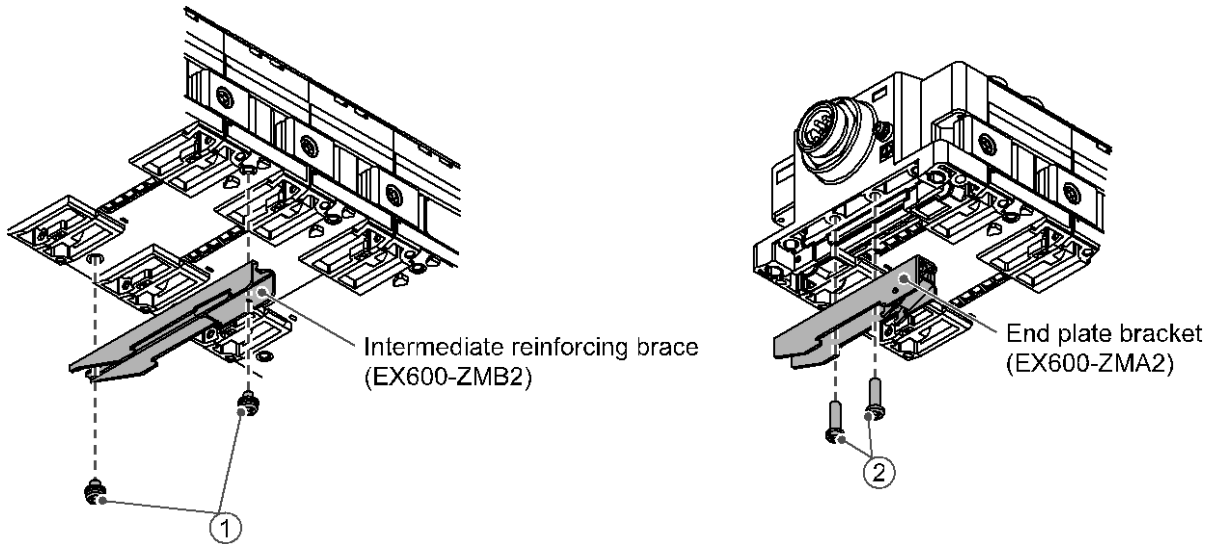

- (3) Hook the DIN rail mounting groove to the DIN rail.
- (4) Press the manifold using its side hooked to the DIN rail as a fulcrum until the manifold is locked.
- (5) Fix the manifold by tightening the DIN rail fixing screws of the EX600-ZMA2. (M4 x 20)

(Tightening torque: 0.7 to 0.8 Nm)

The tightening torque at the valve side depends on the valve type.

Refer to the operation manual of the corresponding valve manifold.

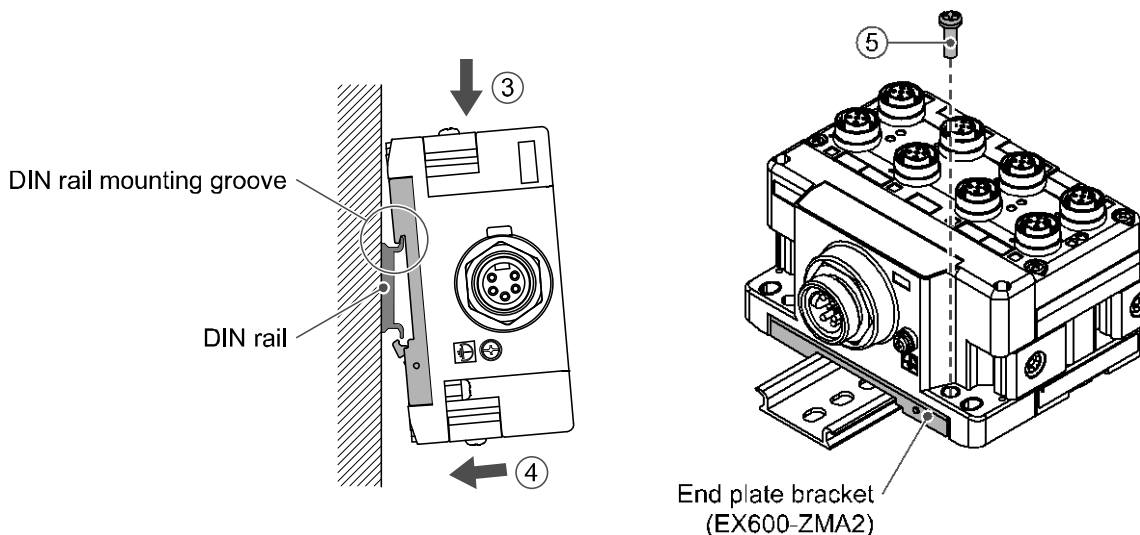

### •Precautions for handling

- When joining six or more units, fix the middle part of the complete unit with an intermediate reinforcing brace to prevent incorrect connection between the units due to deflection.

# SI Unit

## Model Indication and How to Order

**EX600-S CF 1 -X60**

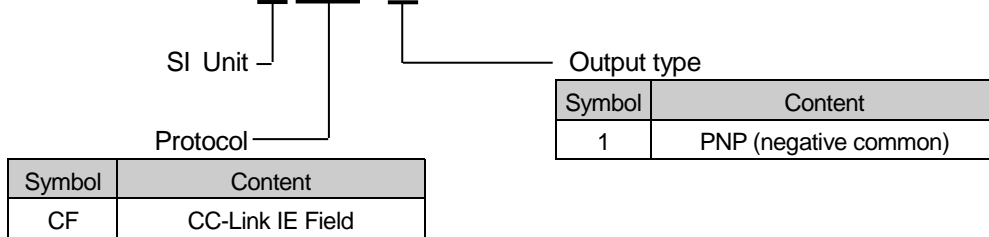

## Summary of Product parts

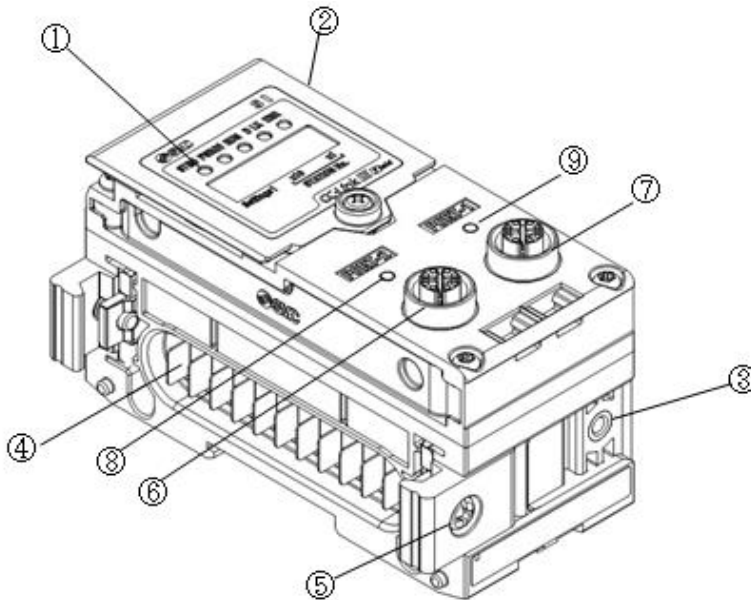

No.	Description	Function
1	Status display LED	Displays the status of the unit.
2	Display cover	Open at the switch configuration.
3	Valve plate mounting screw hole	Fixes the valve plate.
4	Unit connector (plug)	Transmits signals and power supplies to adjacent units.
5	Joint bracket	Bracket for joining to adjacent units.
6	Connector (PORT2)	Connects the communication cable. (M12, 8 pin, socket)
7	Connector (PORT1)	Connects the communication cable. (M12, 8 pin, socket)
8	PORT2 status LED	Displays the communication status of the PORT2 side.
9	PORT1 status LED	Displays the communication status of the PORT1 side.

## Mounting and Installation

### ■ Wiring

Connector pin assignment

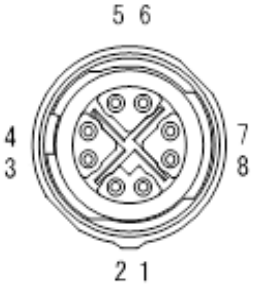
PORT1 / PORT2	Pin No.	Signal name
M12, 8pins, Socket, X-Coded (CAT6A)		
	1	DA+
	2	DA-
	3	DB+
	4	DB-
	5	DD+
	6	DD-
	7	DC-
	8	DC+

#### ● Precautions for handling

Be sure to fit a seal cap on any unused connectors. Proper use of the seal cap enables the enclosure to achieve IP67 specification.

## Setting and Adjustment

### ■ Switch setting

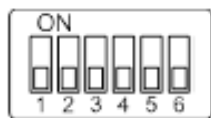

Settings1

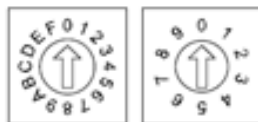

STATION NO.

Settings 1		STATION NO.	
		X10	X1
1	Network No. setting	Sets the position of station numbers 100 and 10	Sets the position of station number 1
2			
3			
4~6	Reserved		

#### ● Precautions for handling

- Turn off the power supply whilst setting the switch.
- When setting the switch, do not touch other unrelated parts. This can cause parts damage or malfunction due to a short circuit.
- When introducing power supply, switch setting will become effective.
- Handle the switch with care. Excessive force can break the switch.
- 4 to 6 of the Settings1 switch are not used. (Never turn it ON.)

• Network number setting switch:

Settings1		Network number
1	2	
OFF	OFF	EEPROM setting mode by CSP+ *1
ON	OFF	1
OFF	ON	2
ON	ON	3

\*1: In EEPROM setting mode, the network number can be set within the range 1 to 239

• Station number setting switch:

Set the station number within the range 1 to 120.

If the station number is set to a value other than 1 to 120, the ERR LED will come on.

STATION NO.	Function	Content
x10	Sets the position of station numbers 100 and 10	1->10, A->100, B->110, C->120
x1	Sets the position of station number 1	

Example:

When station number is 120: set "C" to x10 and "0" to x1

When station number is 111: set "B" to x10 and "1" to x1

•HOLD/CLEAR switch: Sets the output status when the fieldbus has a communication error or is in idling state.

Settings1	Content
1	
OFF	Output is OFF. (default setting)
ON	Holds the output.



## LED Display

LED display shows the power supply and communication status.

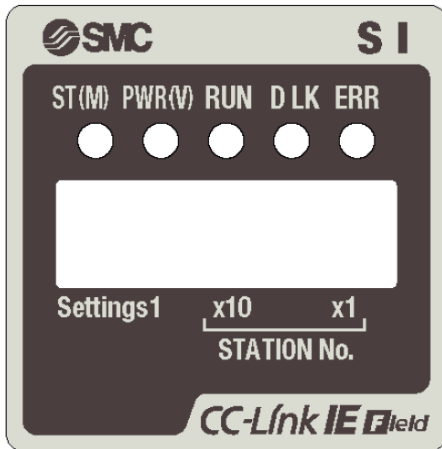

Display	Content
ST(M)	Displays the diagnosis status of the unit.
PWR(V)	Displays the status of the power supply voltage for output.
RUN	Displays the operation status.
DLK	Displays the data link status.
ERR	Displays the network error status.

### •ST(M)-LED

LED display	Content
Green ON	Normal operation.
Green flashing	Diagnostic error of I/O unit is detected.
Red flashing	Either of the following diagnostic error is detected. (When diagnostic parameter is enabled) •Valve ON/OFF counter has exceeded the set value. •Valve is short circuited or disconnected.
Red/green flashing alternately	Detect a communication error between SI unit and I/O unit.
Red ON	SI unit has failed.

### •PWR(V)-LED

LED display	Content
OFF	The power supply for output is OFF or less than 20VDC. (When diagnostic parameter is disable)
Green ON	The power supply for output is properly.
Red ON	The power supply for output is OFF or less than 20VDC (When diagnostic parameter is enable)

•RUN-LED

LED display	Content
OFF	SI unit is in abnormal condition
Green ON	Normal operation

•DLK-LED

LED display	Content
OFF	Data link not implemented.
Green ON	Data link in progress.

•ERR-LED

LED display	Content
OFF	Normal operation
Red ON	Either of the following conditions are detected. •Communication error has occurred. *1 •Station number is set to 0, or to 121 or over. •Network number is not set

\*1. The Master's red ERR LED will come on if the Master request IO size is smaller than the actual slave IO size.

•PORT1 LINK-LED / PORT2 LINK-LED

LED display	Content
OFF	The link is down
Green ON	The link is up
Red ON	The received data are abnormal

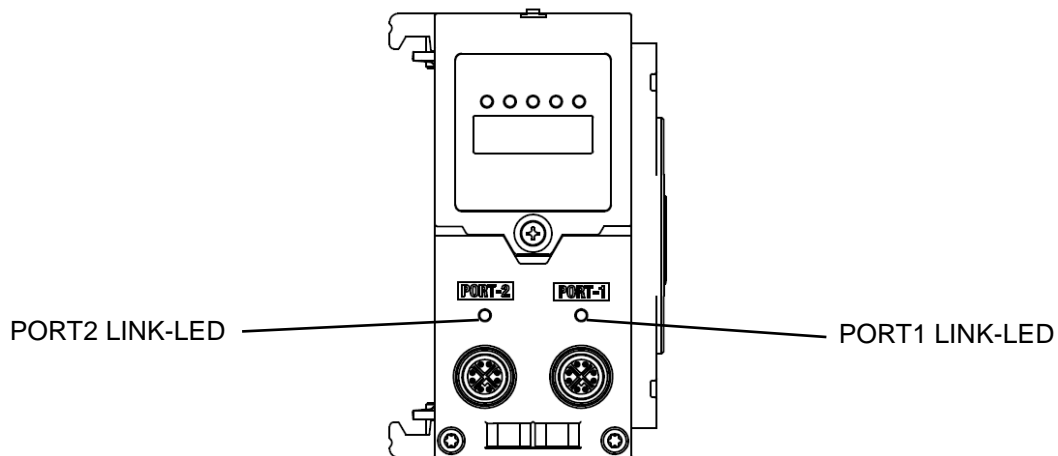

# Specification

## ■ Specifications

Communication	Protocol	CC-Link IE Field
	Station type	Intelligent device station
	Communication speed	1 Gbps
	Station number setting range	1 to 120
	Network number setting range	1 to 239
	Configuration file	CSP+
	Supported topology	Star, Line, Ring
	I/O map size in input side	RX: 32 to 176 bits RW: 32 to 608 words
	I/O map size in output side	RY: 32 to 176 bits RW: 32 to 608 words
Valve Output	Output type	Source / PNP(negative common)
	Number of solenoid valves	32 outputs
	Load	Solenoid valve with surge voltage suppressor of 24 VDC and 1.0 W or less (manufactured by SMC)
	Applicable valve series	SY3000、SY5000、SY7000 VQC1000、VQC2000、VQC4000、VQC5000 SV1000、SV2000、SV3000 S0700
	Output setting during communication fault	HOLD / CLEAR
	Protection	Short circuit protection
Operating temperature range		-10 to 50 °C
Standard		CE marking, RoHS
Weight		300 g

## ■ Dimensions

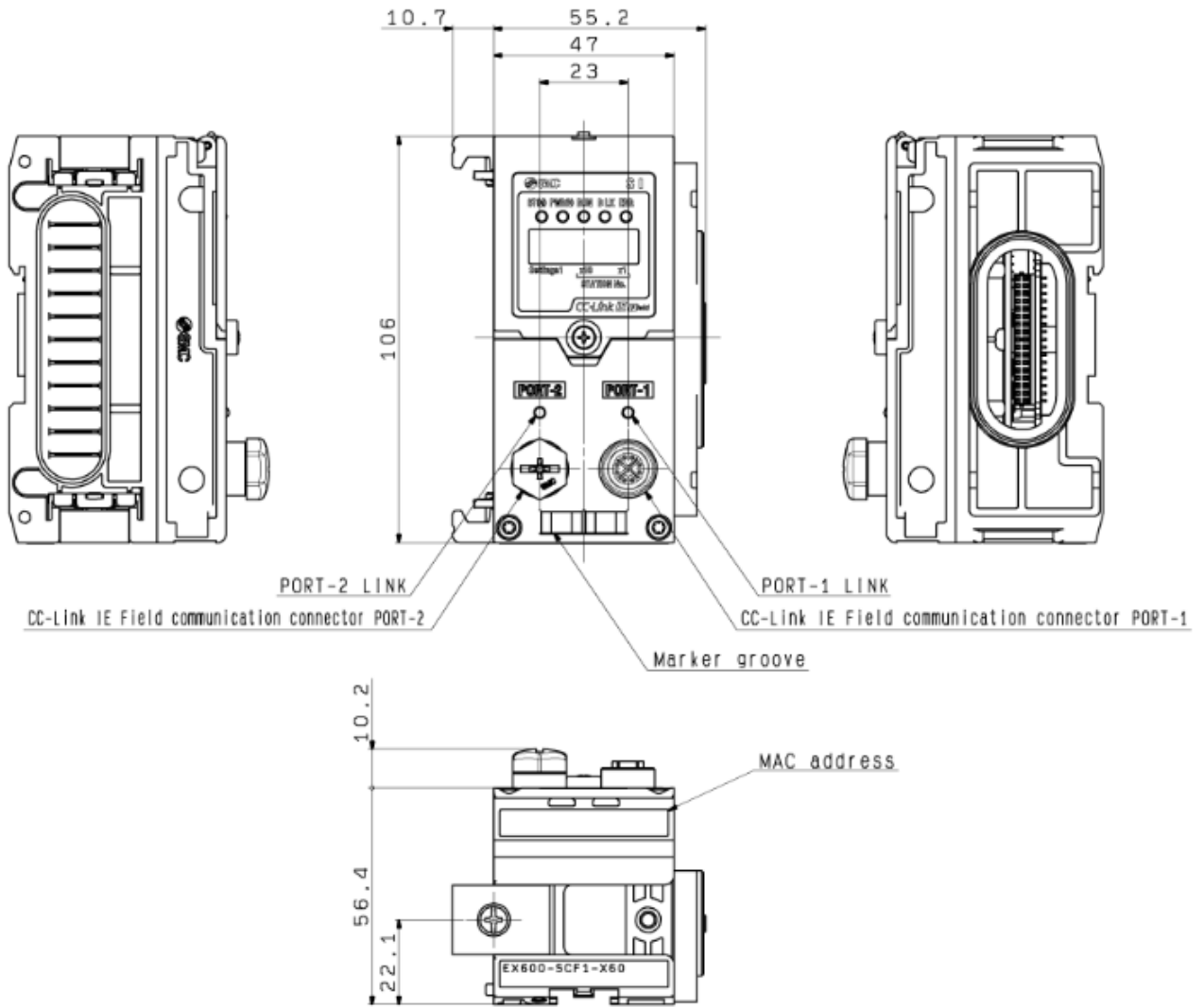

## IO-Link Master Unit

### Model Indication and How to Order

**EX600-GIL B -X60**

IO-Link Master —

Symbol	Connector	Number of IO-Link ports
B	M12 connector (4pins) 4pcs	4

### Summary of Product parts

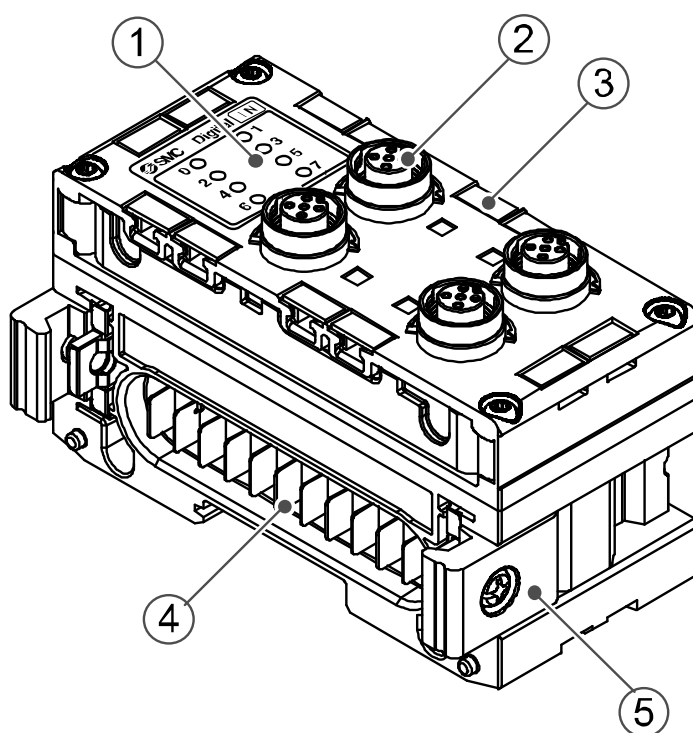

No.	Description	Function
1	Status display LED	Displays the status the unit.
2	Connector	Connects with IO-Link devices.
3	Marker groove	Can be used to mount a marker.
4	Connector for Unit (Plug)	Transmits signals to the neighboring Unit and supplies power.
5	Joint bracket	Links Units to one another.

## Mounting and Installation

### ■ Connector pin assignment (Connector 0 to 3)

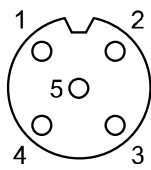
M12, 5pins, socket	Pin No.	Signal name
	1	24V for control and input
	2	Digital input (PNP)
	3	0V for control and input
	4	IO-Link mode / digital input mode (PNP) / digital output mode (PNP) <sup>Note)</sup>
	5	Not used

Note) The function of pin.4 is selectable by parameter.

The below table shows the relationship between the connector No. and IO-Link port No.

Connector No.	IO-Link PORT No.
Connector 0, pin 4	IO-Link PORT 1
Connector 1, pin 4	IO-Link PORT 2
Connector 2, pin 4	IO-Link PORT 3
Connector 3, pin 4	IO-Link PORT 4

## LED Display

LED display shows the IO-Link Master unit status.

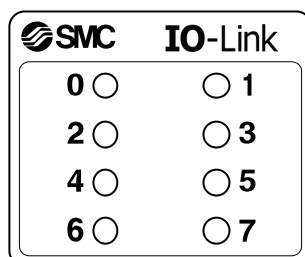

### ■ LED 0, 1, 2, 3

Displays the status of digital input of pin 2 of connectors 0 to 3.

LED No.	LED display	Content
0	OFF	Digital input is OFF (Connector 0, pin 2)
	Orange ON	Digital input is ON (Connector 0, pin 2)
1	OFF	Digital input is OFF (Connector 1, pin 2)
	Orange ON	Digital input is ON (Connector 1, pin 2)
2	OFF	Digital input is OFF (Connector 2, pin 2)
	Orange ON	Digital input is ON (Connector 2, pin 2)
3	OFF	Digital input is OFF (Connector 3, pin 2)
	Orange ON	Digital input is ON (Connector 3, pin 2)

## ■ LED 4, 5, 6, 7

The display differs depending on the function set to pin 4 of connectors 0 to 3.

### 【IO-Link mode】

LED No.	LED display	Content
4	Green ON	IO link connection active. (Connector 0, pin4)
	Flashing Green (2Hz)	No IO-Link connection or wrong IO-Link device. (Connector 0, pin4)
	Flashing Red (2Hz)	Wrong configuration of IO-Link data length. (Connector 0, pin4)
	Red ON	Either of following short circuit is detected at Connector 0 <ul style="list-style-type: none"> <li>•Between pin 1 and pin 3</li> <li>•Between pin 4 and pin 3</li> </ul>
5	Green ON	IO link connection active. (Connector 1, pin4)
	Flashing Green (2Hz)	No IO-Link connection or wrong IO-Link device. (Connector 1, pin4)
	Flashing Red (2Hz)	Wrong configuration of IO-Link data length. (Connector 1, pin4)
	Red ON	Either of following short circuit is detected at Connector 1 <ul style="list-style-type: none"> <li>•Between pin 1 and pin 3</li> <li>•Between pin 4 and pin 3</li> </ul>
6	Green ON	IO link connection active. (Connector 2, pin4)
	Flashing Green (2Hz)	No IO-Link connection or wrong IO-Link device. (Connector 2, pin4)
	Flashing Red (2Hz)	Wrong configuration of IO-Link data length. (Connector 2, pin4)
	Red ON	Either of following short circuit is detected at Connector 2 <ul style="list-style-type: none"> <li>•Between pin 1 and pin 3</li> <li>•Between pin 4 and pin 3</li> </ul>
7	Green ON	IO link connection active. (Connector 3, pin4)
	Flashing Green (2Hz)	No IO-Link connection or wrong IO-Link device. (Connector 3, pin4)
	Flashing Red (2Hz)	Wrong configuration of IO-Link data length. (Connector 3, pin4)
	Red ON	Either of following short circuit is detected at Connector 3 <ul style="list-style-type: none"> <li>•Between pin 1 and pin 3</li> <li>•Between pin 4 and pin 3</li> </ul>

【Digital input mode】

LED No.	LED display	Cpntent
4	OFF	Digital input is OFF ( Connector 0, pin 4 )
	Orange ON	Digital input is ON ( Connector 0, pin 4 )
	Red ON	Short circuit is detected between pin 1 and pin 3 at connector 0.
5	OFF	Digital input is OFF ( Connector 1, pin 4 )
	Orange ON	Digital input is ON ( Connector 1, pin 4 )
	Red ON	Short circuit is detected between pin 1 and pin 3 at connector 1.
6	OFF	Digital input is OFF ( Connector 2, pin 4 )
	Orange ON	Digital input is ON ( Connector 2, pin 4 )
	Red ON	Short circuit is detected between pin 1 and pin 3 at connector 2.
7	OFF	Digital input is OFF ( Connector 3, pin 4 )
	Orange ON	Digital input is ON ( Connector 3, pin 4 )
	Red ON	Short circuit is detected between pin 1 and pin 3 at connector 3.

【Digital output mode】

LED No.	LED display	Cpntent
4	OFF	Digital output is OFF ( Connector 0, pin 4 )
	Orange ON	Digital input is ON ( Connector 0, pin 4 )
	Red ON	Sh ither of following short circuit is detected at Connector 0 <ul style="list-style-type: none"> <li>•Between pin 1 and pin 3</li> <li>•Between pin 4 and pin 3</li> </ul>
5	OFF	Digital output is OFF ( Connector 1, pin 4 )
	Orange ON	Digital input is ON ( Connector 1, pin 4 )
	Red ON	Sh ither of following short circuit is detected at Connector 1 <ul style="list-style-type: none"> <li>•Between pin 1 and pin 3</li> <li>•Between pin 4 and pin 3</li> </ul>
6	OFF	Digital output is OFF ( Connector 2, pin 4 )
	Orange ON	Digital input is ON ( Connector 2, pin 4 )
	Red ON	Sh ither of following short circuit is detected at Connector 2 <ul style="list-style-type: none"> <li>•Between pin 1 and pin 3</li> <li>•Between pin 4 and pin 3</li> </ul>
7	OFF	Digital output is OFF ( Connector 3, pin 4 )
	Orange ON	Digital input is ON ( Connector 3, pin 4 )
	Red ON	Sh ither of following short circuit is detected at Connector 3 <ul style="list-style-type: none"> <li>•Between pin 1 and pin 3</li> <li>•Between pin 4 and pin 3</li> </ul>



# Specification

## ■ Specifications

IO-Link version		Version 1.1	
IO-Link port type		Class A	
Communication speed		COM1 ( 4.8kBaud ) COM2 ( 38.4kBaud ) COM3 (230.4kBaud ) Depending on connected sensor / actuator	
Number of IO-Link ports		4	
Input specifications	Pin No.	Pin 2 input	Pin 4 input
	Input type	PNP	
	Max. device supply current	0.5A / connector ( 2A / unit )	
	Protective function	Short circuit protection	
	Input resistance	4.7 kΩ	—
	Rated input current	5mA or less	12mA or less
	ON voltage	17V or more	13V or more
	OFF voltage	5V or less	8V or less
Output specifications	Output type	PNP	
	Max. load current	0.25A / output (Supply from power supply for control and input)	
	Protective function	Short circuit protection	
Enclosure		IP67 ( Manifold assembly )	
Standards		CE Marking, RoHS Compliant	
weight		300g	

## ■ Dimensions

•EX600-GILB-X60

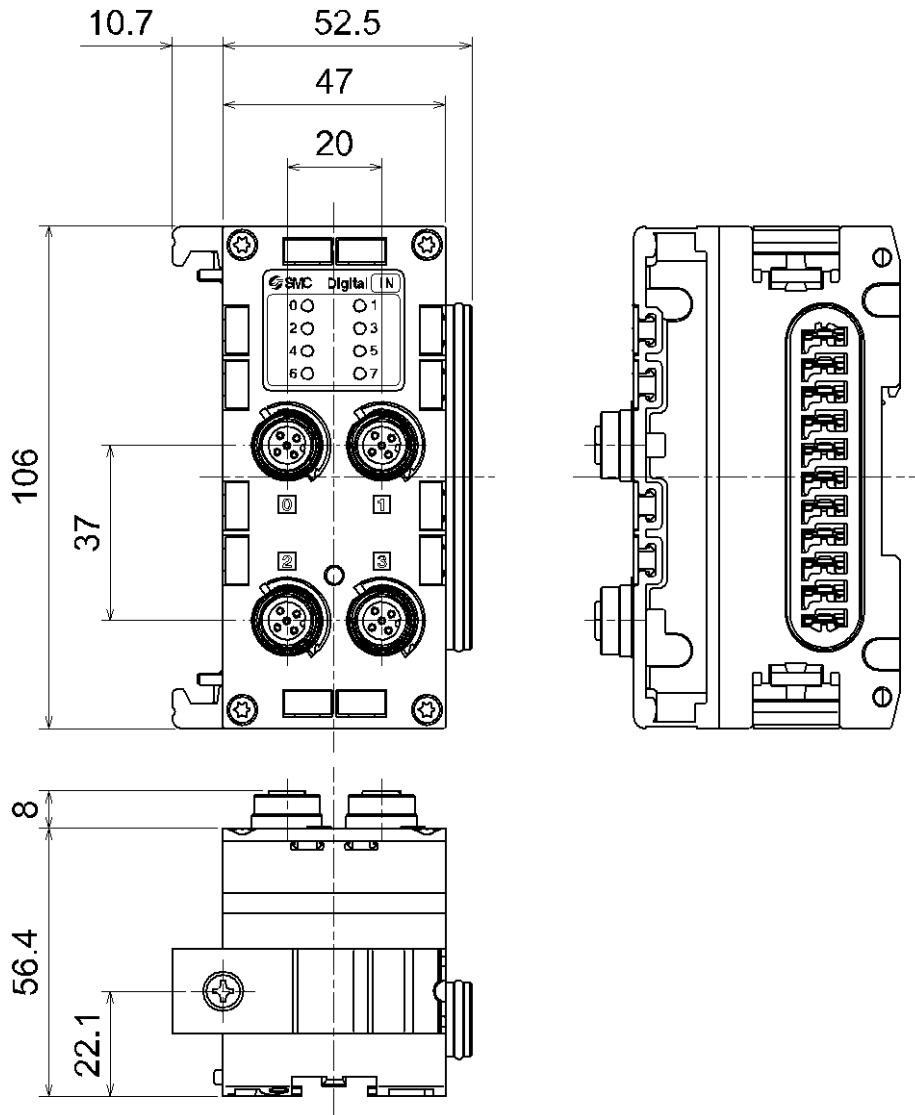

## End plate

### Model Indication and How to Order

**EX600-ED□-□**

End plate at D side

Mounting method

Connector

Symbol	Content
2	M12 (5 pin)
3	7/8 inch (5 pin)

Symbol	Content
Nil	No DIN rail bracket
2	With DIN rail bracket (Except SY series)
3	With DIN rail bracket (Specified for SY series)

### Summary of Product parts

•EX600-ED2-□

•EX600-ED3-□

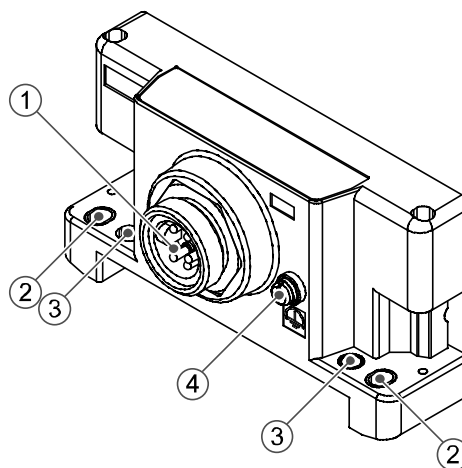
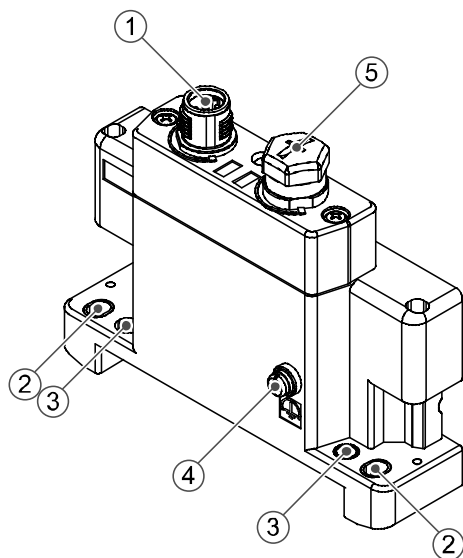

No.	Description	Function
1	Power connector	Connector for power supply to SI unit and I/O unit.
2	Fixing hole for direct mounting	Holes for direct mounting.
3	DIN rail fixing hole	Holes for fix DIN rail mounting.
4	F.E. terminal *	Functional Earth terminal - must be connected directly to system earth (ground).
5	Connector (Not used)	Unused connector. Do not remove seal cap.

\*: Individual grounding should be provided close to the product with a short cable.

# Mounting and Installation

## ■ Wiring

○ Connector pin assignment

(1) EX600-ED2-□

Configuration	Pin No.	Signal name
	1	24 V (Output)
	2	0 V (Output)
	3	24 V (Control and input)
	4	0 V (Control and input)
	5	F.E.

(2) EX600-ED3-□

Configuration	Pin No.	Signal name
	1	0 V (Output)
	2	0 V (Control and input)
	3	F.E.
	4	24 V (Control and input)
	5	24 V (Output)

○ Regarding the 2 types of power supply

The power supply consists of two power supply systems as follows:

- Power supply for control and input: Supplying power for control of each unit's power supply for control and also for device connected to input port of Digital, Analog and IO-Link mater unit.
- Power supply for output: Supplying power for equipment connected to output port of Digital and Analog unit, and also power supply for solenoid valve manifold.

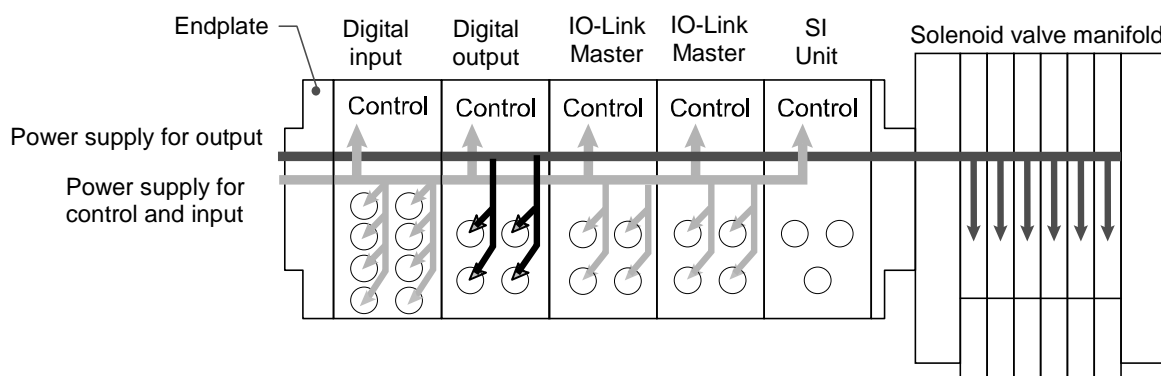

### ● Precautions for handling

Be sure to fit a seal cap on any unused connectors. Proper use of the seal cap enables the enclosure to achieve IP67 specification.

# Specification

## Specifications

Model		EX600-ED2-□	EX600-ED3-□
Power	Power connector	M12 (5 pin) Plug	7/8 inch (5 pin) Plug
	Power supply (Control and input)	24 VDC ±10% Class2, 2 A	24 VDC ±10%, 8 A
	Power supply (Output)	24 VDC +10/-5% Class2, 2 A	24 VDC +10/-5%, 8 A
Environment	Enclosure	IP67 (With manifold assembled) *1	
	Operating temperature range	-10 to 50 °C	
	Storage temperature range	-20 to 60 °C	
	Operating humidity range	35 to 85%R.H. (No condensation)	
	Withstand voltage	500 VAC for 1 minute between external terminals and F.E.	
	Insulation resistance	500 VDC, 10 MΩ min. between external terminals and F.E.	
Standard		CE marking, UL (CSA), RoHS	
Weight		170 g	175 g

\*1: All unused connectors must have a seal cap fitted.

## Dimensions

•EX600-ED2-□

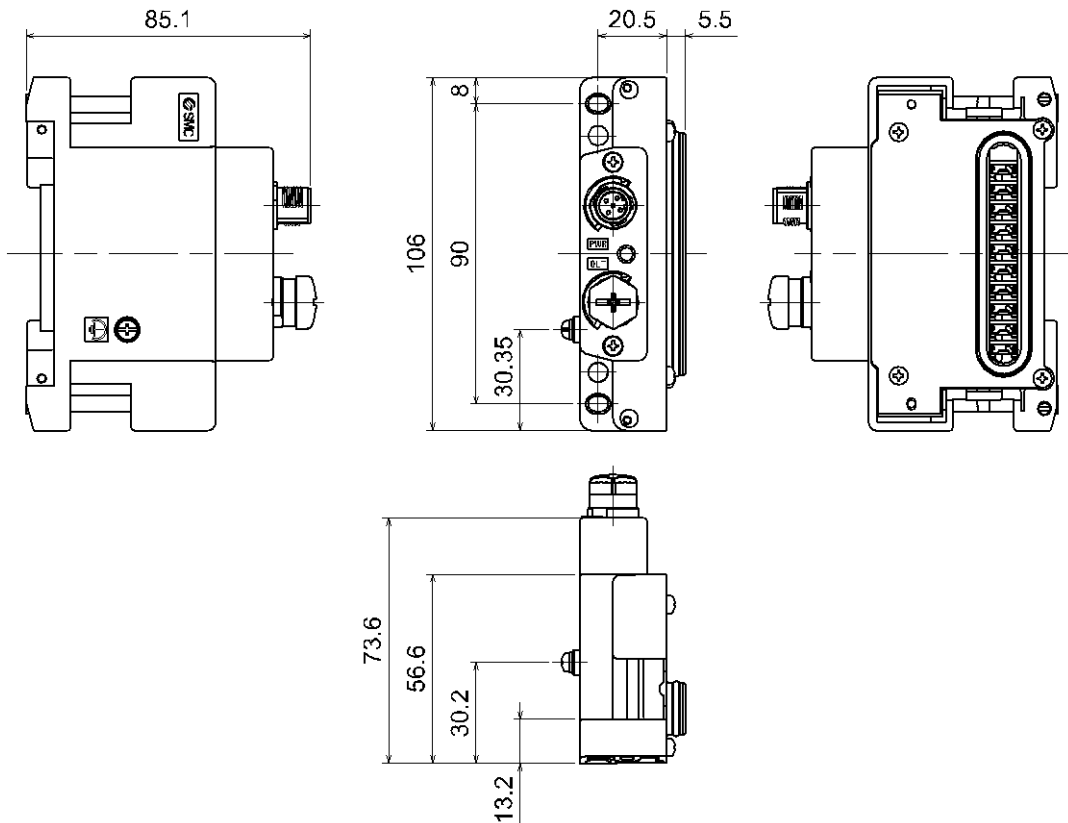

•EX600-ED3-□

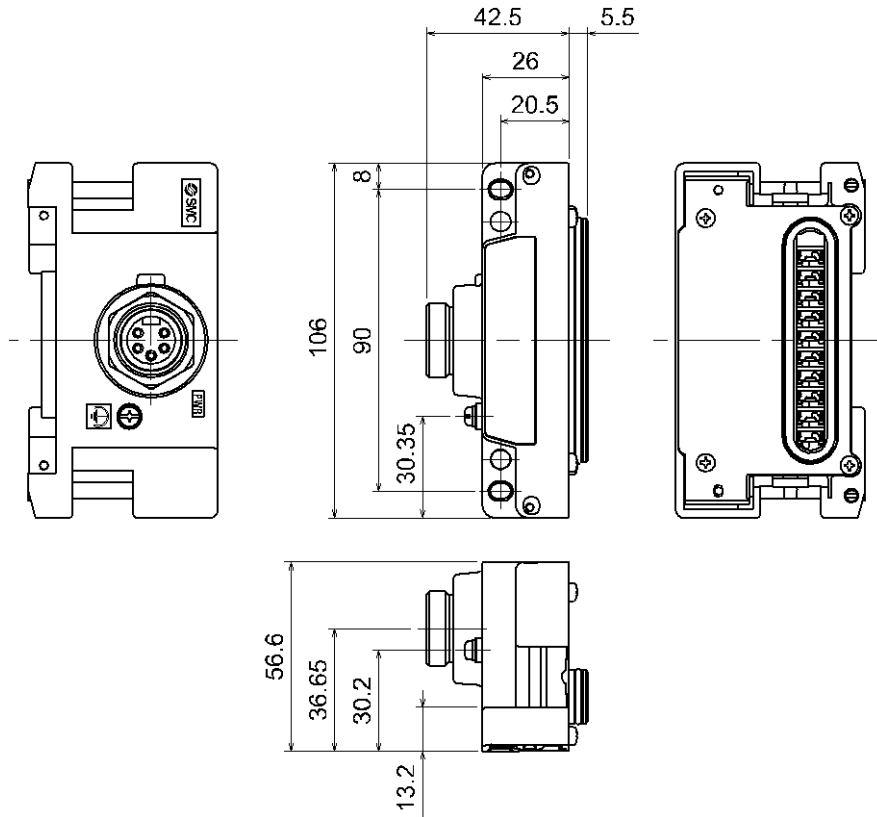

## I/O Map

The allocated input and output memory size for each EX600 unit are shown below.

Unit	Unit part number	Allocated memory size			
		Bit area		Word area	
		Input (RX)	Output (RY)	Input (RWr)	Output (RWw)
SI Unit	EX600-SCF1	(32 bit)	32 bit	32 word	(32 word)
Digital input unit	EX600-DX#B (8 inputs)	16 bit <sup>*2</sup>	(16 bit)	—	—
	EX600-DX#C (8 inputs)	16 bit <sup>*2</sup>	(16 bit)	—	—
	EX600-DX#C1 (8 inputs)	16 bit <sup>*2</sup>	(16 bit)	—	—
	EX600-DX#D (16inputs)	16 bit	(16 bit)	—	—
	EX600-DX#E (16 inputs)	16 bit	(16 bit)	—	—
	EX600-DX#F (16 inputs)	16 bit	(16 bit)	—	—
Digital output unit	EX600-DY#B (8 outputs)	(16 bit)	16 bit <sup>*2</sup>	—	—
	EX600-DY#E (16 outputs)	(16 bit)	16 bit	—	—
	EX600-DY#F (16 outputs)	(16 bit)	16 bit	—	—
Digital I/O unit	EX600-DM#E (8 inputs / 8 outputs)	16 bit <sup>*2</sup>	16 bit <sup>*2</sup>	—	—
	EX600-DM#F (8 inputs / 8 outputs)	16 bit <sup>*2</sup>	16 bit <sup>*2</sup>	—	—
Analogue input Unit	EX600-AXA (2ch)	—	—	4 word <sup>*3</sup>	(4 word)
Analogue output Unit	EX600-AYA (2ch)	—	—	(4 word)	4 word <sup>*3</sup>
Analogue I/O Unit	EX600-AMB (2ch/2ch)	—	—	4 word <sup>*3</sup>	4 word <sup>*3</sup>
IO-Link Master Unit	EX600-GILB	16 bit	16 bit	64 word	64 word

\*1: Content given in brackets ( ) is reserve data.

\*2: Most significant 8 bits are 0.

\*3: Most significant 2 words are 0.

## ■ I/O map example

In CC-Link IE field compatible EX600, Unit No. is allocated in order from SI unit side.  
The I/O map is shown with the following unit configuration as an example.

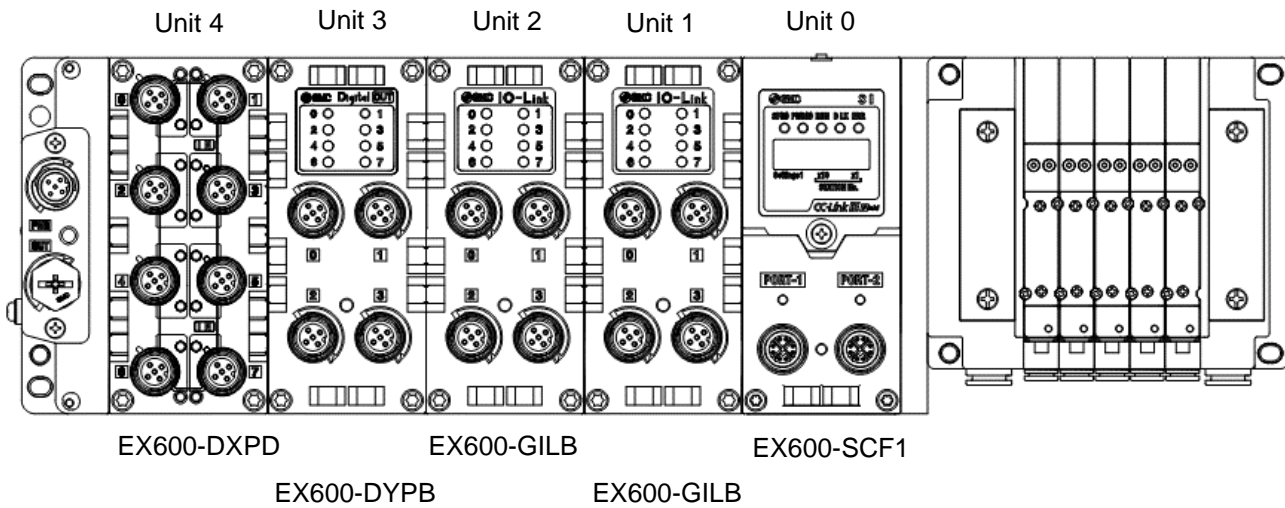

### 【Allocated memory size】

Unit No,	Unit part number	Unit type	Allocated memory size			
			Bit area		Word area	
			Input (RX)	Output (RY)	Input (RW <sub>r</sub> )	Output (RW <sub>w</sub> )
0	EX600-SCF1-X60	SI unit	32 bit	32 bit	32 word	32 word
1	EX600-GILB-X60	IO-Link Master	16 bit	16 bit	64 word	64 word
2	EX600-GILB-X60	IO-Link Master	16 bit	16 bit	64 word	64 word
3	EX600-DYPB	Digital outputs (8 outputs)	16 bit	16 bit	—	—
4	EX600-DXPB	Digital inputs (16 inputs)	16 bit	16 bit	—	—
<b>Total</b>			<b>96 bit</b>	<b>96 bit</b>	<b>160 word</b>	<b>160 word</b>



**【I/O map】**

The following is an input/output map for the bit and word areas.

Data for the input and output registers is sent between the Master and Slave using cyclic transmission.

• Bit area (1)

Input register	Slave -> Master	Output register	Master -> Slave	Corresponding Unit No.
RXn.0	Reserve	RYn.0	Valve output 0	Unit No.0 EX600-SCF1
RXn.1		RYn.1	Valve output 1	
RXn.2		RYn.2	Valve output 2	
RXn.3		RYn.3	Valve output 3	
RXn.4		RYn.4	Valve output 4	
RXn.5		RYn.5	Valve output 5	
RXn.6		RYn.6	Valve output 6	
RXn.7		RYn.7	Valve output 7	
RXn.8		RYn.8	Valve output 8	
RXn.9		RYn.9	Valve output 9	
RXn.A		RXn.A	Valve output 10	
RXn.B		RYn.B	Valve output 11	
RXn.C		RYn.C	Valve output 12	
RXn.D		RYn.D	Valve output 13	
RXn.E		RYn.E	Valve output 14	
RXn.F		RYn.F	Valve output 15	
RX(n+1).0		RY(n+1).0	Valve output 16	
RX(n+1).1		RY(n+1).1	Valve output 17	
RX(n+1).2		RY(n+1).2	Valve output 18	
RX(n+1).3		RY(n+1).3	Valve output 19	
RX(n+1).4		RY(n+1).4	Valve output 20	
RX(n+1).5		RY(n+1).5	Valve output 21	
RX(n+1).6		RY(n+1).6	Valve output 22	
RX(n+1).7		RY(n+1).7	Valve output 23	
RX(n+1).8		RY(n+1).8	Valve output 24	
RX(n+1).9		RY(n+1).9	Valve output 25	
RX(n+1).A		RY(n+1).A	Valve output 26	
RX(n+1).B		RY(n+1).B	Valve output 27	
RX(n+1).C		RY(n+1).C	Valve output 28	
RX(n+1).D		RY(n+1).D	Valve output 29	
RX(n+1).E		RY(n+1).E	Valve output 30	
RX(n+1).F		RY(n+1).F	Valve output 31	

n: Start address

• Bit area (2)

Input register	Slave -> Master	Output register	Master -> Slave	Corresponding Unit No.
RX(n+2).0	Digital input 0 (CN0, pin.2)	RY(n+2).0	Rserve	Unit No.1 EX600-GILB
RX(n+2).1	Digital input 1 (CN1, pin.2)	RY(n+2).1		
RX(n+2).2	Digital input 2 (CN2, pin.2)	RY(n+2).2		
RX(n+2).3	Digital input 3 (CN3, pin.2)	RY(n+2).3		
RX(n+2).4	Digital input 4 (CN0, pin.4)	RY(n+2).4	Digital output 0 (CN0, pin.4)	
RX(n+2).5	Digital input 5 (CN1, pin.4)	RY(n+2).5	Digital output 1 (CN1, pin.4)	
RX(n+2).6	Digital input 6 (CN2, pin.4)	RY(n+2).6	Digital output 2 (CN2, pin.4)	
RX(n+2).7	Digital input 7 (CN3, pin.4)	RY(n+2).7	Digital output 3 (CN3, pin.4)	
RX(n+2).8	IO-Link Port 1 event flag	RY(n+2).8	Reserve	
RX(n+2).9	IO-Link Port 2 event flag	RY(n+2).9		
RX(n+2).A	IO-Link Port 3 event flag	RX(n+2).A		
RX(n+2).B	IO-Link Port 4 event flag	RY(n+2).B		
RX(n+2).C	Reserve	RY(n+2).C		
RX(n+2).D		RY(n+2).D		
RX(n+2).E		RY(n+2).E		
RX(n+2).F		RY(n+2).F		
RX(n+3).0	Digital input 0 (CN0, pin.2)	RY(n+2).0	Rserve	Unit No.2 EX600-GILB
RX(n+3).1	Digital input 1 (CN1, pin.2)	RY(n+2).1		
RX(n+3).2	Digital input 2 (CN2, pin.2)	RY(n+2).2		
RX(n+3).3	Digital input 3 (CN3, pin.2)	RY(n+2).3		
RX(n+3).4	Digital input 4 (CN0, pin.4)	RY(n+2).4	Digital output 0 (CN0, pin.4)	
RX(n+3).5	Digital input 5 (CN1, pin.4)	RY(n+2).5	Digital output 1 (CN1, pin.4)	
RX(n+3).6	Digital input 6 (CN2, pin.4)	RY(n+2).6	Digital output 2 (CN2, pin.4)	
RX(n+3).7	Digital input 7 (CN3, pin.4)	RY(n+2).7	Digital output 3 (CN3, pin.4)	
RX(n+3).8	IO-Link Port 1 event flag	RY(n+2).8	Reserve	
RX(n+3).9	IO-Link Port 2 event flag	RY(n+2).9		
RX(n+3).A	IO-Link Port 3 event flag	RX(n+2).A		
RX(n+3).B	IO-Link Port 4 event flag	RY(n+2).B		
RX(n+3).C	Reserve	RY(n+2).C		
RX(n+3).D		RY(n+2).D		
RX(n+3).E		RY(n+2).E		
RX(n+3).F		RY(n+2).F		

n: Start address

• Bit area (3)

Input register	Slave -> Master	Output register	Master -> Slave	Corresponding Unit No.	
RX(n+4).0	Reserve	RY(n+4).0	Digital output 0	Unit No.3 EX600-DYPB	
RX(n+4).1		RY(n+4).1	Digital output 1		
RX(n+4).2		RY(n+4).2	Digital output 2		
RX(n+4).3		RY(n+4).3	Digital output 3		
RX(n+4).4		RY(n+4).4	Digital output 4		
RX(n+4).5		RY(n+4).5	Digital output 5		
RX(n+4).6		RY(n+4).6	Digital output 6		
RX(n+4).7		RY(n+4).7	Digital output 7		
RX(n+4).8		Reserve	RY(n+4).8		Reserve
RX(n+4).9			RY(n+4).9		
RX(n+4).A			RY(n+4).A		
RX(n+4).B			RY(n+4).B		
RX(n+4).C			RY(n+4).C		
RX(n+4).D			RY(n+4).D		
RX(n+4).E			RY(n+4).E		
RX(n+4).F			RY(n+4).F		
RX(n+4).0	Digital input 0	RY(n+4).0	Reserve	Unit No.4 EX600-DXPD	
RX(n+4).1	Digital input 1	RY(n+4).1			
RX(n+4).2	Digital input 2	RY(n+4).2			
RX(n+4).3	Digital input 3	RY(n+4).3			
RX(n+4).4	Digital input 4	RY(n+4).4			
RX(n+4).5	Digital input 5	RY(n+4).5			
RX(n+4).6	Digital input 6	RY(n+4).6			
RX(n+4).7	Digital input 7	RY(n+4).7			
RX(n+4).8	Digital input 8	RY(n+4).8			
RX(n+4).9	Digital input 9	RY(n+4).9			
RX(n+4).A	Digital input 10	RY(n+4).A			
RX(n+4).B	Digital input 11	RY(n+4).B			
RX(n+4).C	Digital input 12	RY(n+4).C			
RX(n+4).D	Digital input 13	RY(n+4).D			
RX(n+4).E	Digital input 14	RY(n+4).E			
RX(n+4).F	Digital input 15	RY(n+4).F			

n: Start address

• Word area (1)

Input register	Slave -> Master	Output register	Master -> Slave	Corresponding Unit No.
RWr(n+0)	System diagnosis	RWw(n+0)	Reserve	Unit No.0 EX600-SCF1
RWr(n+1)	Unit diagnosis	RWw(n+1)		
RWr(n+2)	Unit No.0 Channel diagnosis	RWw(n+2)		
RWr(n+3)		RWw(n+3)		
RWr(n+4)		RWw(n+4)		
RWr(n+5)	Unit No.1 Channel diagnosis	RWw(n+5)		
RWr(n+6)		RWw(n+6)		
RWr(n+7)		RWw(n+7)		
RWr(n+8)	Unit No.2 Channel diagnosis	RWw(n+8)		
RWr(n+9)		RWw(n+9)		
RWr(n+A)		RWw(n+A)		
RWr(n+B)	Unit No.3 Channel diagnosis	RWw(n+B)		
RWr(n+C)		RWw(n+C)		
RWr(n+D)		RWw(n+D)		
RWr(n+E)	Unit No.4 Channel diagnosis	RWw(n+E)		
RWr(n+F)		RWw(n+F)		
RWr(n+10)		WWw(n+10)		
RWr(n+11)	Unit No.5 Channel diagnosis	WWw(n+11)		
RWr(n+12)		WWw(n+12)		
RWr(n+13)		WWw(n+13)		
RWr(n+14)	Unit No.6 Channel diagnosis	WWw(n+14)		
RWr(n+15)		WWw(n+15)		
RWr(n+16)		WWw(n+16)		
RWr(n+17)	Unit No.7 Channel diagnosis	WWw(n+17)		
RWr(n+18)		WWw(n+18)		
RWr(n+19)		WWw(n+19)		
RWr(n+1A)	Unit No.8 Channel diagnosis	WWw(n+1A)		
RWr(n+1B)		WWw(n+1B)		
RWr(n+1C)		WWw(n+1C)		
RWr(n+1D)	Unit No.9 Channel diagnosis	WWw(n+1D)		
RWr(n+1E)		WWw(n+1E)		
RWr(n+1F)		WWw(n+1F)		

n: Start address

• Word area (2)

Input register	Slave -> Master	Output register	Master -> Slave	Corresponding Unit No.
RWr(n+20)	IO-Link Process data Port 1	RWw(n+20)	IO-Link Process data Port 1	Unit No.1 EX600-GILB
RWr(n+21)		RWw(n+21)		
:		:		
RWr(n+2E)		RWw(n+2E)		
RWr(n+2F)		RWw(n+2F)		
RWr(n+30)	IO-Link Process data Port 2	RWw(n+30)	IO-Link Process data Port 2	
RWr(n+31)		RWw(n+31)		
:		:		
RWr(n+3E)		RWw(n+3E)		
RWr(n+3F)		RWw(n+3F)		
RWr(n+40)	IO-Link Process data Port 3	RWw(n+40)	IO-Link Process data Port 3	
RWr(n+41)		RWw(n+41)		
:		:		
RWr(n+4E)		RWw(n+4E)		
RWr(n+4F)		RWw(n+4F)		
RWr(n+50)	IO-Link Process data Port 4	RWw(n+50)	IO-Link Process data Port 4	
RWr(n+51)		RWw(n+51)		
:		:		
RWr(n+5E)		RWw(n+5E)		
RWr(n+5F)		RWw(n+5F)		
RWr(n+60)	IO-Link Process data Port 1	RWw(n+60)	IO-Link Process data Port 1	Unit No.2 EX600-GILB
RWr(n+61)		RWw(n+61)		
:		:		
RWr(n+6E)		RWw(n+6E)		
RWr(n+6F)		RWw(n+6F)		
RWr(n+70)	IO-Link Process data Port 2	RWw(n+70)	IO-Link Process data Port 2	
RWr(n+71)		RWw(n+71)		
:		:		
RWr(n+7E)		RWw(n+7E)		
RWr(n+7F)		RWw(n+7F)		
RWr(n+80)	IO-Link Process data Port 3	RWw(n+80)	IO-Link Process data Port 3	
RWr(n+81)		RWw(n+81)		
:		:		
RWr(n+8E)		RWw(n+8E)		
RWr(n+8F)		RWw(n+8F)		
RWr(n+90)	IO-Link Process data Port 4	RWw(n+90)	IO-Link Process data Port 4	
RWr(n+91)		RWw(n+91)		
:		:		
RWr(n+9E)		RWw(n+9E)		
RWr(n+9F)		RWw(n+9F)		

n: Start address

## ■ Details of diagnostic data

### • System diagnosis

Input register	Bit No.	Diagnostic content
RWr(n+0)	0	The power supply voltage for output device is outside of the specification.
	1	The power supply voltage for control and input device is outside of the specification.
	2	Reserved
	3	There is a connection failure between each unit (During operation).
	4	There is a connection failure between each unit (When the power supply is applied).
	5	Reserved
	6	System error occurred.
	7	Hardware error occurred.
	8	The analog value has fallen below the user set value.
	9	The analog value has exceeded the user set value.
	A	The analog input value has fallen below the set range.
	B	The analog input value has exceeded the set range.
	C	The ON/OFF counter has exceeded the set value.
	D	The open circuit has been detected.
	E	The short circuit of the valve output or digital output has been detected.
F	The short circuit of the power supply for the input/output device has been detected.	

n: Start address

### • Unit diagnosis

Input register	Bit No.	Diagnostic content
RWr(n+1)	0	There is an error in unit 0.
	1	There is an error in unit 1.
	2	There is an error in unit 2.
	3	There is an error in unit 3.
	4	There is an error in unit 4.
	5	There is an error in unit 5.
	6	There is an error in unit 6.
	7	There is an error in unit 7.
	8	There is an error in unit 8.
	9	There is an error in unit 9.
	A	Reserve
	B	
	C	
	D	
	E	
F		

n: Start address

• Channel diagnosis

Input register	Bit No.	Diagnostic content
RWr(n+2) Unit No.0 RWr(n+5) Unit No.1 : RWr(n+1A) Unit No.8 RWr(n+1D) Unit No.9	0~7	Reserve
	8	The analogue value has fallen below the user set value.
	9	The analogue value has exceeded the user set value.
	A	Reserve
	B	Reserve
	C	The ON/OFF counter has exceeded the set value.
	D	The open circuit has been detected.
	E	The short circuit of the valve output or digital output has been detected.
F	The short circuit of the power supply for the input/output device has been detected.	
RWr(n+3) Unit No.0 RWr(n+6) Unit No.1 : RWr(n+1B) Unit No.8 RWr(n+1E) Unit No.9	0	There is an error in channel 0.
	:	:
	F	There is an error in channel 15.
RWr(n+4) Unit No.0 RWr(n+7) Unit No.1 : RWr(n+1C) Unit No.8 RWr(n+1F) Unit No.9	0	There is an error in channel 16.
	:	:
	F	There is an error in channel 31.

n: Start address

## Parameter Setting

The EX600 parameters can be configured for the system, each unit and each channel.

Parameters can be changed using the Network Parameter Window, or by acyclic command.

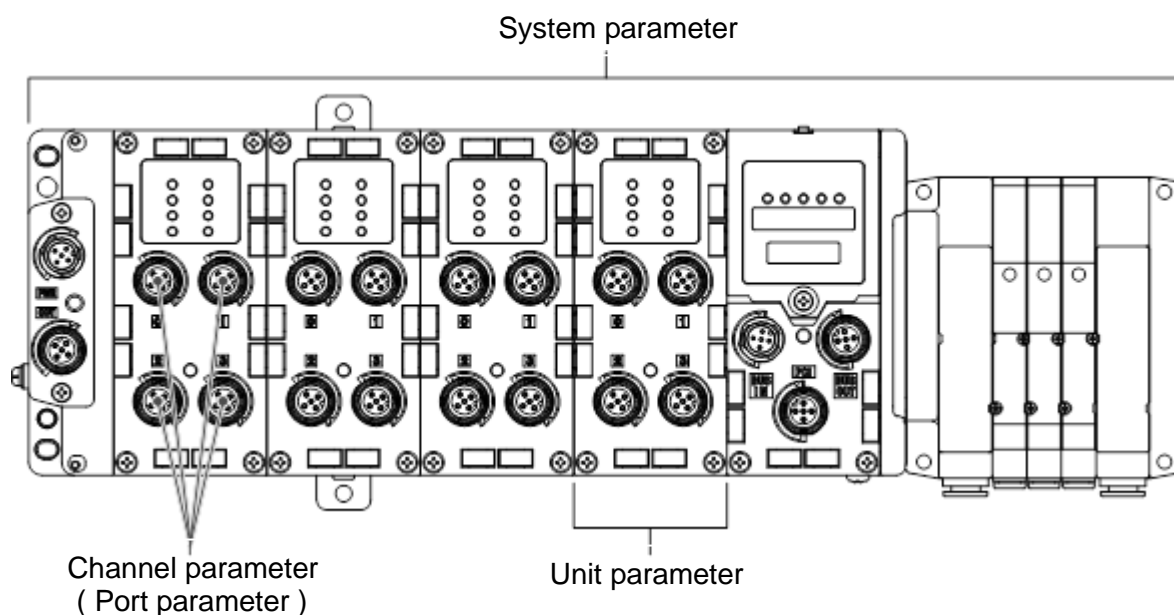

### ■ Parameter definition and setting

With EX600 series, parameters can be set for each unit.

The table below shows settable parameters for the SI unit and input/output units.

#### •SI unit parameters (1)

No.	Parameter	Definition	Item	Content	Default setting	Parameter setting range
1	Hold/Clear priority setting	Switch the setting of the output during communication error or communication idling to follow the setting of the SI unit or the parameters.	Via switch	Setting by SI unit switch becomes valid. OFF/Hold can be set output of all.	○	System
			Via software	Setting by parameter becomes valid. OFF/Hold/Forced ON can be set per channel.		
2	Power supply for control and input voltage monitor	Generated error when control and input power supply voltage is less than approx.18 V.	Enable	Generates an error.	○	Unit
			Disable	Does not generate an error.		
3	Power supply for output voltage monitor	Generated error when output power supply voltage is less than approx.19 V.	Enable	Generates an error.	○	Unit
			Disable	Does not generate an error.		



•SI unit parameters (2)

No.	Parameter	Definition	Item	Content	Default setting	Parameter setting range
4	Short Circuit Detection	Generates error when the short circuit of the valve is detected.	Enable	Generates an error.	○	Unit
			Disable	Does not generate an error.		
5	Restart after short circuit	Restore the setting of short circuit detection error after the valve short circuit is cleared.	Auto	Error is automatically cleared when the short circuit is fixed.	○	Unit
			Manual	Even when the short circuit is fixed, error is not cleared until the power is supplied again.		
6	Open Circuit Detection	Generates error when the disconnection of the valve is detected.	Enable	Generates an error.		Channel
			Disable	Does not generate an error.	○	
7	Output setting during communication fault *1	Sets output when communication error is occurred.	Clear	Turn off the output	○	Channel
			Hold	Hold the output		
			ForceON	Turn on the output forcefully		
8	Output setting during communication idling *1 *2	Output setting at the time of communication idling	Clear	Turn off the output	○	Channel
			Hold	Hold the output		
			ForceON	Turn on the output forcefully		
9	Valve ON/OFF counter	Generates error when the operation count exceeds the set value. *3	Enable	Generates an error. Val: 1 to 65000 *4		Channel
			Disable	Does not generate an error.	○	
10	Valve ON/OFF counter clear	Clears the valve ON/OFF counter to 0.	-	-	-	-
			-	-	-	

\*1: This function is valid only when "Hold/Clear priority" of the system parameter is set to "Via software".

\*2: Some PLC does not support an idle mode.

\*3: The count is memorized every hour. When the power supply is turned on again, counting starts from the last value memorized.

\*4: Times for setting is set value x1000 times.

•Digital input unit parameters

No.	Parameter	Definition	Item	Content	Default setting	Parameter setting range
1	The power supply short circuit detection for control and input	Generates error when the short circuit of the power supply for the input device is detected.	Enable	Generates an error.	○	Unit
			Disable	Does not generate an error.		
2	Open circuit detection *1	Generates error when the disconnection of the input device is detected. *2	Enable	Generates an error.	○	Channel
			Disable	Does not generate an error.		
3	Inrush current filter	Selects the over current detection for 100 msec after supplying power.	Enable	Ignores inrush current.	○	Unit
			Disable	Does not ignore inrush current.		
4	Input filtering time	Sets the time to ignore the input signal change.	0.1 ms	Selects the time for filtering.	1.0 ms	Unit
			1.0 ms			
			10 ms			
			20 ms			
5	Input extension time	Sets the time to hold the input signal.	1.0ms	Selects the time to hold the input signal.	15 ms	Unit
			15 ms			
			100 ms			
			200 ms			
6	Input ON/OFF counter	Generates error when the operation count exceeds the set value. *3	Enable	Generates an error. Val: 1 to 65000 *4	○	Channel
			Disable	Does not generate an error.		
7	Input ON/OFF counter clear	Clears the Input ON/OFF counter to 0.	-	-	-	-

\*1: Disconnection detection is a function only available for digital unit (EX600-DXPC1, EX600-DXNC1) with disconnection detection.

\*2: 2-wire type input equipment cannot be correctly detected if its leakage current is 0.5 mA or less while the equipment is in the OFF state (reed sensor, etc.).

Ensure that all input equipment used has a leakage current above 0.5 mA in the OFF state.

3-wire type input equipment cannot be correctly detected if its current consumption is 0.5 mA or less.

The open circuit of input signals cannot be detected.

\*3: The count is memorized every hour. When the power supply is turned on again, counting starts from the last value memorized.

\*4: Times for setting is set value x1000 times.

•Digital output unit parameters

No.	Parameter	Definition	Item	Content	Default setting	Parameter setting range
1	Output load short circuit detection	Generates error when the short circuit of the output device is detected. *1	Enable	Generates an error.	○	Unit
			Disable	Does not generate an error.		
2	Restart after output load short circuit	Restore the setting of short circuit detection error after the output device short circuit is cleared.	Auto	Error is automatically cleared when the short circuit is fixed.	○	Unit
			Manual	Even when the short circuit is fixed, error is not cleared until the power is supplied again.		
3	Open circuit detection	Generates error when the disconnection of the output device is detected.	Enable	Generates an error.		Channel
			Disable	Does not generate an error.	○	
4	Output setting during communication fault *2	Sets output when communication error is occurred.	Clear	Turn off the output	○	Channel
			Hold	Hold the output		
			ForceON	Turn on the output forcefully		
5	Output setting during communication idling *2 *3	Sets output during communication idling.	Clear	Turn off the output	○	Channel
			Hold	Hold the output		
			ForceON	Turn on the output forcefully		
6	Output ON/OFF counter	Generates error when the operation count exceeds the set value. *4	Enable	Generates an error. Val: 1 to 65000 *5		Channel
			Disable	Does not generate an error.	○	
7	Output ON/OFF counter clear	Clears the Output ON/OFF counter to 0.	—	—	—	—

\*1: Could be incorrectly recognized as short circuit depending on used load (ex.: lamp load). If detection is incorrect, disable the parameter setting.

\*2: This function is valid only when "Hold/Clear priority" of the system parameter is set to "Via software".

\*3: Some PLC does not support an idle mode.

\*4: The count is memorized every hour. When the power supply is turned on again, counting starts from the last value memorized.

\*5: Times for setting is set value x1000 times.

•Digital I/O unit parameters (1)

No.	Parameter	Definition	Item	Content	Default setting	Parameter setting range
1	The power supply short circuit detection for control and input	Generates error when the short circuit of the control or input power supply is detected.	Enable	Generates an error.	○	Unit
			Disable	Does not generate an error.		
2	Inrush current filter	Select the over current detection for 100 msec after supplying power.	Enable	Ignores inrush current.		Unit
			Disable	Does not ignore inrush current.	○	
3	Input filtering time	Sets the time to ignore the input signal change.	0.1 ms	Selects the time for filtering.	1.0 ms	Unit
			1.0 ms			
			10 ms			
			20 ms			
4	Input extension time	Sets the time to hold the input signal.	1.0 ms	Selects the time to hold the input signal.	15 ms	Unit
			15 ms			
			100 ms			
			200 ms			
5	Output load short circuit detection	Generates error when the short circuit of the output device is detected. *1	Enable	Generates an error.	○	Unit
			Disable	Does not generate an error.		
6	Restart after output load short circuit	Restore the setting of short circuit detection error after the output device short circuit is cleared.	Auto	Error is automatically cleared when the short circuit is fixed.	○	Unit
			Manual	Even when the short circuit is fixed, error is not cleared until the power is supplied again.		
7	Open circuit detection	Generates error when the disconnection of the output device is detected.	Enable	Generates an error.		Channel
			Disable	Does not generate an error.	○	
8	Output setting during communication fault *2	Sets output when Communication error is occurred.	Clear	Turn off the output	○	Channel
			Hold	Hold the output		
			ForceON	Turn on the output forcefully		
9	Output setting for communication idling *2 *3	Sets output during communication idling.	Clear	Turn off the output	○	Channel
			Hold	Hold the output		
			ForceON	Turn on the output forcefully		

•Digital I/O unit parameters (2)

No.	Parameter	Definition	Item	Content	Default setting	Parameter setting range
10	Input or Output ON/OFF counter	Generates error when the operation count exceeds the set value. *4	Enable	Generates an error. Val: 1 to 65000 *5		Channel
			Disable	Does not generate an error.	○	
11	Input or Output ON/OFF counter clear	Clears the Input or Output ON/OFF counter to 0.	-	-	-	-

\*1: Could be incorrectly recognized as short circuit depending on used load (ex.: lamp load). If detection is incorrect, disable the parameter setting.

\*2: This function is valid only when "Hold/Clear priority" of the system parameter is set to "Via software".

\*3: Some PLC does not support an idle mode.

\*4: The count is memorized every hour. When the power supply is turned on again, counting starts from the last value memorized.

\*5: Times for setting is set value x1000 times.

•Analog input unit parameters

No.	Parameter	Definition	Item	Content	Default setting	Parameter setting range
1	The power supply short circuit detection for the input device	Generates error when the short circuit of the power supply for the input device is detected.	Enable	Generates an error.	○	Unit
			Disable	Does not generate an error.		
2	Analog input range	Sets the analogue input device range.	-10..10 V	Selects the analog input range.	-10..10 V	Channel
			-5..5 V			
			-20..20 mA			
			0..10 V			
			0.5 V			
			1..5 V			
			0..20 mA			
4..20 mA						
3	Analog data format	Sets analogue data type which is output to PLC.	Offset binary	Offset binary.	○	Unit
			Sign & Magnitude	Signed binary.		
			2s complement	2's complement.		
4	Analog average filter	Sets analog filtering time.	None	None	○	Channel
			2AVG	2 value average		
			4AVG	4 value average		
			8AVG	8 value average		
5	Over range detection	Generates error when the input value exceeds 0.5% of full span.	Enable	Generates an error.	○	Unit
			Disable	Does not generate an error.		
6	Under range detection	Generates error when the input value falls below 0.5% of full span.	Enable	Generates an error.	○	Unit
			Disable	Does not generate an error.		
7	User setting value upper limit error	Generates error when the input value exceeds the set value.	Enable	Generates an error. *1	○	Channel
			Disable	Does not generate an error.		
8	User setting value lower limit error	Generates error when the input value falls below the set value.	Enable	Generates an error. *1	○	Channel
			Disable	Does not generate an error.		

\*1: Set value shall be set per analogue input range within settable range in the table below.

When the analog input range is changed, check the set value and change it to an appropriate value.

Table. Settable range of user set value

Range	Settable value range	
	Lower limit	Upper limit
-10..+10 V	-10.50 to +10.45 V	-10.45 to +10.50 V
-5..+5 V	-5.25 to +5.22 V	-5.22 to +5.25 V
-20..+20 mA	-21.00 to +20.90 mA	-20.90 to +21.00 mA
0..10 V	0.00 to +10.45 V	+0.05 to +10.50 V
0..5 V	0.00 to +5.22 V	+0.03 to +5.25 V
1..5 V	+0.75 to +5.22 V	+0.78 to +5.25 V
0..20 mA	0.00 to +20.90 mA	+0.10 to +21.00 mA
4..20 mA	+3.00 to +20.90 mA	+3.10 to +21.00 mA

•Analog output unit parameters (1)

No.	Parameter	Definition	Item	Content	Default setting	Parameter setting range
1	The power supply short circuit detection for the output device	Generates error when the short circuit of the output device is detected.	Enable	Generates an error.	○	Unit
			Disable	Does not generate an error.		
2	Analog output range	Sets the range of the analog output device.	0..10 V	Selects the analog output range.	0..10 V	Channel
			0..5 V			
			1..5 V			
			0..20 mA			
			4..20 mA			
3	Analog data format	Sets analogue data type which is output to PLC.	Offset binary	Offset binary.	○	Unit
			Sign & Magnitude	Signed binary.		
			2s complement	2's complement.		
			Scaled	Scale conversion type.		
4	User setting value upper limit error	Generates error when the output value exceeds the set value.	Enable	Generates an error. *1		Channel
	Disable	Does not generate an error.	○			
4	Scale upper limit setting	Sets the scale upper limit. Generates error when the output value exceeds the upper limit.	Enable	Generates an error. Val: -32766 to 32767		Channel
			Disable	Does not generate an error. Val: -32766 to 32767	○ Val: 1000	
5	User setting value lower limit error	Generates error when the output value falls below the set value.	Enable	Generates an error. *1		Channel
	Disable	Does not generate an error.	○			
5	Scale lower limit setting	Sets the scale lower limit. Generates error when the output value falls below the lower limit.	Enable	Generates an error. Val: -32767 to 32766		Channel
			Disable	Does not generate an error. Val: -32767 to 32766	○ Val: 0	
6	Output setting for communication error *2	Sets output when communication error is occurred.	Enable	Output will be user fault value. *1		Channel
			Disable	Output will be held last state.	○	



•Analog output unit parameters (2)

No.	Parameter	Definition	Item	Content	Default setting	Parameter setting range
7	Output setting for communication idling *2 *3	Sets output during communication idling.	Enable	Output will be user idle value. *1		Channel
			Disable	Output will be held last state.	○	

\*1: Set value shall be set per analog input range within settable range in the table below.

When the analogue input range is changed, check the set value and change it to an appropriate value.

\*2: This function is valid only when "Hold/Clear priority" of the system parameter is set to "Via software".

\*3: Some PLC does not support an idle mode.

Settable range for user set upper or lower limit and output value at communication error and idling

Range	Settable range		
	Actual analog signal value	Set value	
		Offset Binary, Signed Magnitude and 2's Complement format	Scale conversion format
0..10 V	0.00 to +10.50 V	0 to 1050	(-32767) to (+32767)
0..5 V	0.00 to +5.25 V	0 to 525	
1..5 V	+0.75 to +5.25 V	75 to 525	
0..20 mA	0.00 to +21.00 mA	0 to 2100	
4..20 mA	+3.00 to +21.00 mA	300 to 2100	

\*: When the data format is a type other than scale conversion, input the desired voltage or current x 100 in decimal system.

\*: If the data format is scaled data format, set the data between -32767 and +32767, regardless of the range setting.

•Analog I/O unit parameters (1)

No.	Parameter	Definition	Item	Content	Default setting	Parameter setting range
1	The power supply short circuit detection for the input or output device	Generates error when the short circuit of the input device power supply or output device is detected.	Enable	Generates an error.	○	Unit
			Disable	Does not generate an error.		
2	Analog input or output range	Sets the analog input or output range.	0..10 V	Select the analog input or output range.	1.5 V	Channel
			0..5 V			
			1..5 V			
			0..20 mA			
			4..20 mA			
3	Analog data format	Sets analog data type which is output to PLC.	Offset binary	Offset binary.	○	Unit
			Sign & Magnitude	Signed binary.		
			2s complement	2's complement.		
			Scaled	Scale conversion type.		
4	Analog average filter	Sets analog input filtering time.	None	None		Channel
			2AVG	2 value average	○	
			4AVG	4 value average		
			8AVG	8 value average		
5	Over range detection	Generates error when the input value exceeds 0.5% of full span.	Enable	Generates an error.		Unit
			Disable	Does not generate an error.	○	
6	Under range detection	Generates error when the input value falls below 0.5% of full span.	Enable	Generates an error.		Unit
			Disable	Does not generate an error.	○	
7	User's set value upper limit error	Generates error when the input or output value exceeds the set value.	Enable	Generates an error. *1		Channel
			Disable	Does not generate an error.	○	
	Scale upper limit setting	Sets the scale upper limit. Generates error when the input or output value exceeds the upper limit.	Enable	Generates an error. Val: -32766 to 32767		
			Disable	Does not generated an error. Val: -32766 to 32767	○ Val: 1000	

•Analog I/O unit parameters (2)

No.	Parameter	Definition	Item	Content	Default setting	Parameter setting range
8	User's set value lower limit error	Generates error when the input or output value falls below the lower limit.	Enable	Generates an error. *1		Channel
			Disable	Does not generate an error.	○	
	Scale lower limit setting	Sets the scale lower limit. Generates error when the input or output value falls below the lower limit.	Enable	Generates an error. Val: -32767 to 32766		
			Disable	Does not generate an error. Val: -32767 to 32766	○ Val: 0	
9	Output setting for communication fault *2	Sets output when communication error is occurred.	Enable	Output will be user fault value. *1		Channel
			Disable	Output will be held last state.	○	
10	Output setting for communication idling *2 *3	Sets output during communication idling.	Enable	Output will be user idle value. *1		Channel
			Disable	Output will be held last state.	○	

\*1: Set value shall be set per analog output range within settable range in the table below.

When the analog output range is changed, check the set value and change it to an appropriate value.

\*2: This function is valid only when "Hold/Clear priority" of the system parameter is set to "Via software".

\*3: Some PLC does not support an idle mode.

Settable range for user set upper or lower limit and output value at communication error and idling

Range	Settable range		
	Actual analog signal value	Set value	
		Offset Binary, Signed Magnitude and 2's Complement format	Scale conversion format
0..10 V	0.00 to +10.50 V	0 to 1050	(-32767) to (+32767)
0..5 V	0.00 to +5.25 V	0 to 525	
1..5 V	+0.75 to +5.25 V	75 to 525	
0..20 mA	0.00 to +21.00 mA	0 to 2100	
4..20 mA	+3.00 to +21.00 mA	300 to 2100	

\*: When the data format is a type other than scale conversion, input the desired voltage or current x 100 in decimal system.

\*: If the data format is scaled data format, set the data between -32767 and +32767, regardless of the range setting.

•IO-Link Master unit parameters (1)

No.	Parameter	Definition	Item	Content	Default setting	Parameter setting range
1	The power supply short circuit detection for control and input	Generate error when either of following short circuit is detected. •Between pin1 and pin3 •Between pin4 and pin3	Enable	Generates an error.	○	Unit
			Disable	Does not generate an error.		
2	Pin 4 mode setting	Pin 4 function	Inactive	Inactive	○	Port
			IO-Link	IO-Link port		
			Input	Digital input		
			Output	Digital output		
3	Validation mode	To set whether or not to check the Device ID and Vendor ID of Device to be connected	No Check	Regardless of the ID, all the devices can be connected	○	Port
			Compatible	Can be connected only device ID matches		
4	Cycle time	Cycle time for polling of devices.	0 to 1328 ( 0 to 132.8ms )	0 : Automatically set to minimum cycle time of the device. 0.4-6.4ms : Set with increments of 0.1ms. 6.4-32ms : Set with increments of 0.4ms. 32-132.8ms : Set with increments of 1.6ms.	0	Port
5	Vendor ID	Set the vendor ID of the device to be connected	0 to 0xFFFF	Enter a numeric value	0	Port
6	Device ID	Set the device ID of the device to be connected	0 to 0xFFFF	Enter a numeric value	0	Port
7	Process data format (Input data)	Byte order of process data within one word	Enable	The data format of process is assumed to be MSB-LSB.		Port
			Disable	The data format of process is assumed to be LSB-MSB.	○	
		Process data size of input	1 to 32 *1	Setting the input data size	2	
8	Process data format (output data)	Byte order of process data within one word	Enable	The data format of process is assumed to be MSB-LSB.		Port
			Disable	The data format of process is assumed to be LSB-MSB.	○	
		Process data size of output	1 to 32 *1	Setting the output data size	2	

\*1: Set the data size according to the process data size of the IO-Link device.

When the process data size is 0 byte, set it to 1 byte.

•IO-Link Master unit parameters (2)

No.	Parameter	Definition	Item	Content	Default setting	Parameter setting range
9	Data Storage	The setting of the Data Storage mechanism, save and restore the Device parameters	Disable	Data storage is disable. The device parameters stored in the data storage are cleared.	○	Port
			Restore	Download parameters saved in the data storage to the device. Also, if the data storage is cleared, the device parameters are stored in the data storage when IO - Link is connected		
			Backup/Restore	The device parameters are stored in the data storage, when a backup request is generated from the device, Also, when IO - Link is connected, if there is a difference between the data storage device and the device parameter data, download the parameter to the device.		

# Parameter setting with network parameter window

The parameter of EX600 can be set by using the network parameter window by registering the CSP file (0x0123\_EX600-SCF1- X60\_en.cspp) in GX Works.

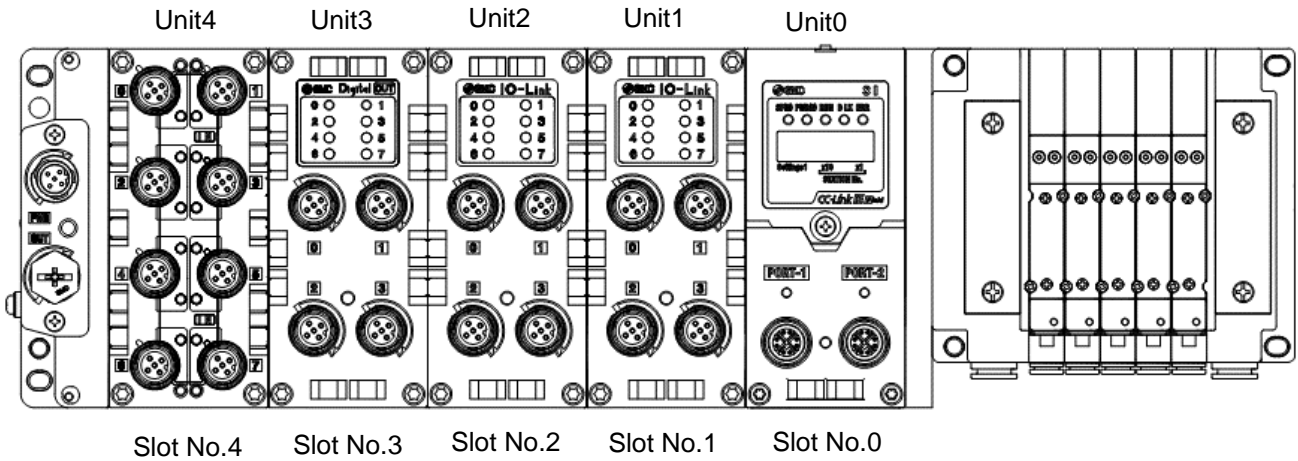

## Parameter setting of EX600

[Setting of network parameter]

Project ⇒ Parameter ⇒ Network Parameter ⇒ Ethernet/CC IE/MELSECNET  
⇒ CC IE Field Configuration Setting

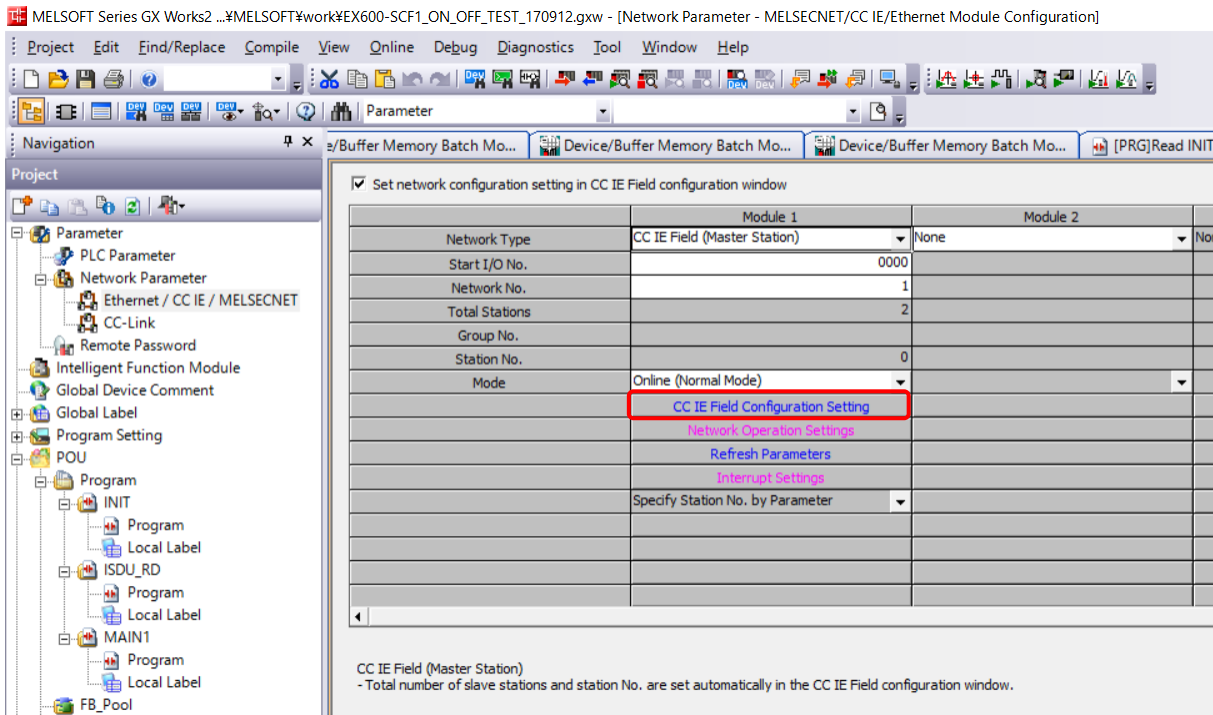

**【Select Module】**

Module List ⇒ CC IE Field Module(SMC Corporation) ⇒ EX600 Series ⇒ EX600-SCF1-X60

**【Setting of parameter】**

EX600-SCF1-X60 ⇒ Online ⇒ Parameter Processing of Slave Station

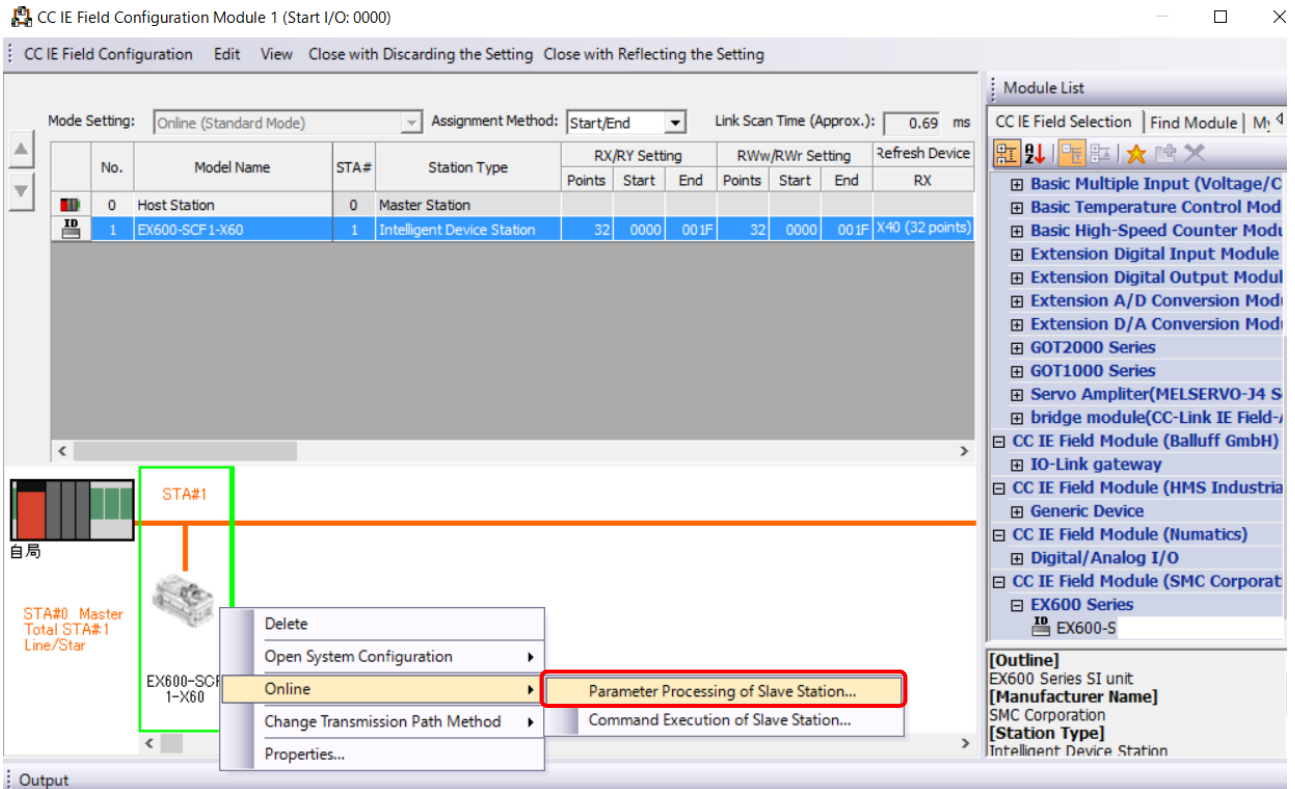

### 【Parameter Processing of Slave Station】

- 1) When the parameter of SI unit is set, Slot No. need not be specified.
- 2) This configures which unit (from 1 to 9) has its parameters read or written first, when reading or writing parameters other than those of the SI unit.  
(For unit 1, set Select Slot No. to 1.)
- 3) There is no need to re-specify the Slot No. when setting the parameters for the same unit more than once.
- 4) Method selection ⇒ Select Slot No ⇒ Slot No. Input a value from 1 to 9 and put a check in the box.
- 5) Click Execute to finish specifying a unit from 1 to 9.

Parameter Processing of Slave Station

Target Module Information: EX600-SCF1-X60  
Start I/O No.:0000 - Station No.:1

Method selection: Select Slot No.

Parameter Information

Checked parameters are the targets of selected processes.

Select All Cancel All Selections

	Name	Initial Value	Unit	Read Value	Unit	Write Value	Unit	Setting Range	Description
<input checked="" type="checkbox"/>	Select Slot No.					<input type="text"/>		1 to 9	
	Slot No.								

Clear All "Read Value" Clear All "Write Value"

Process Option

There is no option in the selected process.

-The refreshed device values of remote I/O or remote registers may be overwritten.  
-Accesses the PLC CPU by using the current connection destination. Please check if there is any problem with the connection destination.  
-Process is executed according to the parameters written in the PLC CPU.  
-For information on items not displayed on the screen, please refer to the Operating Manual.

Execute

Import... Export... Close



**【Read parameter】**

- 1) Method selection ⇒ Read Digital I/O unit Unit Parameter(ex. When you read the unit parameter of a digital unit) ⇒ The check box is selected
- 2) The Execute button is pushed ⇒ Reading of the parameter of the selected unit is executed

The Method selection list is shown below.

Table. The Method selection

Method selection	Parameter	unit
Read SI unit Unit Parameter	Unit parameter	SI unit
Read SI unit Channel Parameter	Channel parameter	
Read Digital I/O unit Unit Parameter	Unit parameter	Digital input unit Digital output unit Digital i/o unit
Read Digital I/O unit Channel Parameter	Channel parameter	
Read Analog I/O unit Unit Parameter	Unit parameter	
Read Analog I/O unit Channel Parameter	Channel parameter	Analog input unit Analog output unit Analog i/o unit
Read IO-Link Master unit Port Parameter	Port parameter	IO-Link Master unit

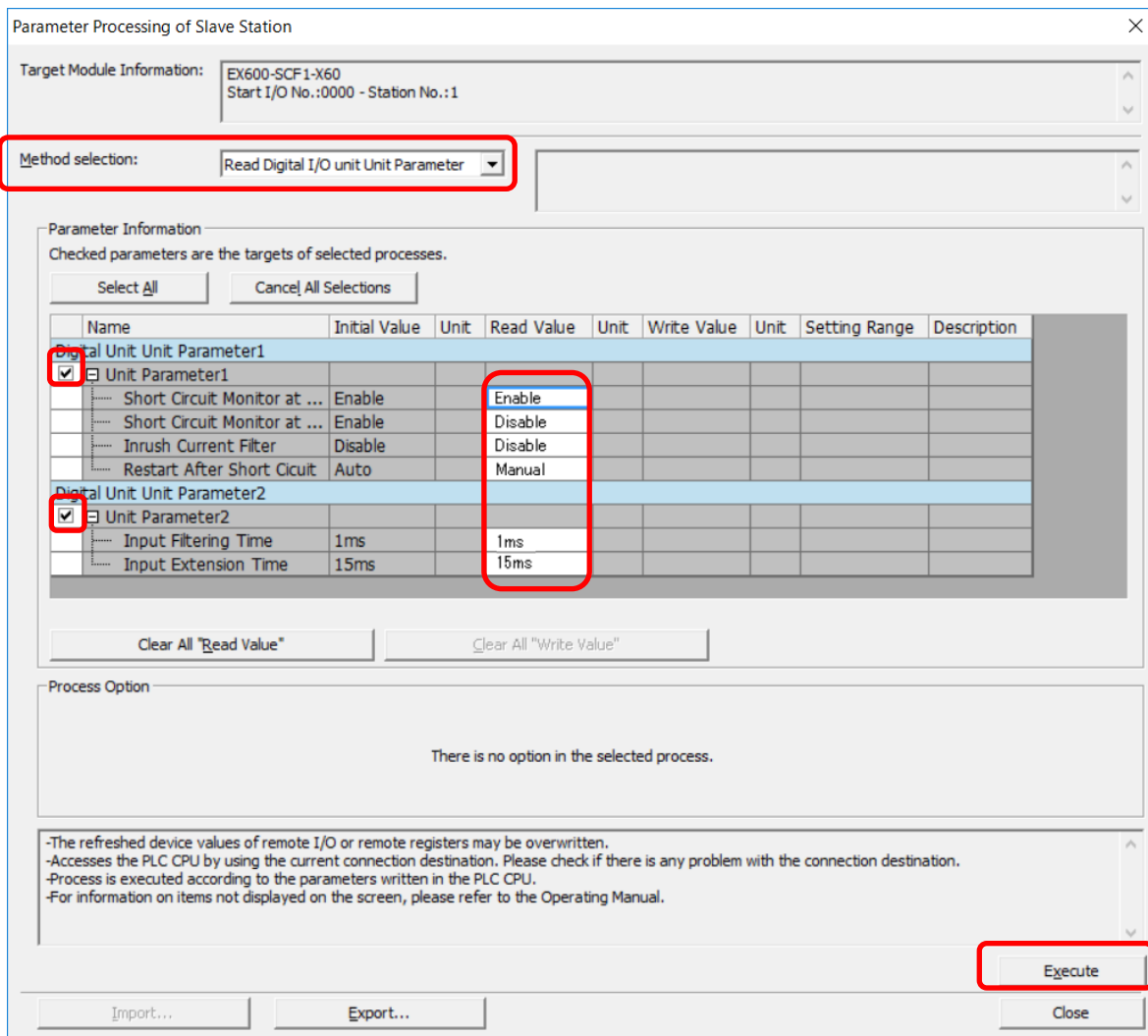

**【Write parameter】**

- 1) Method selection ⇒ Write Digital I/O unit Unit Parameter(ex. When you read the unit parameter of a digital unit) ⇒ The check box is selected
- 2) The writing data is set to write value.
- 3) The Execute button is pushed ⇒ Writing of the parameter of the selected unit is executed

\*The Method selection list is shown below.

\*To write the IO-Link port parameters, it is necessary to execute "Send IO-Link Master Unit Port Parameter" after executing "Write IO-Link Master Unit Port Parameter".

Table. The Method selection

Method selection	Parameter	unit
Write SI unit Unit Parameter	Unit parameter	SI unit
Write SI unit Channel Parameter	Channel parameter	
Write Digital I/O unit Unit Parameter	Unit parameter	Digital input unit Digital output unit Digital i/o unit
Write Digital I/O unit Channel Parameter	Channel parameter	
Write Analog I/O unit Unit Parameter	Unit parameter	Analog input unit Analog output unit Analog i/o unit
Write Analog I/O unit Channel Parameter	Channel parameter	
Write IO-Link Master unit Unit Parameter	Unit parameter	IO-Link Master unit
Write IO-Link Master unit Port Parameter	Port parameter	
Send IO-Link Master unit Port Parameter	Port parameter write confirmation command	

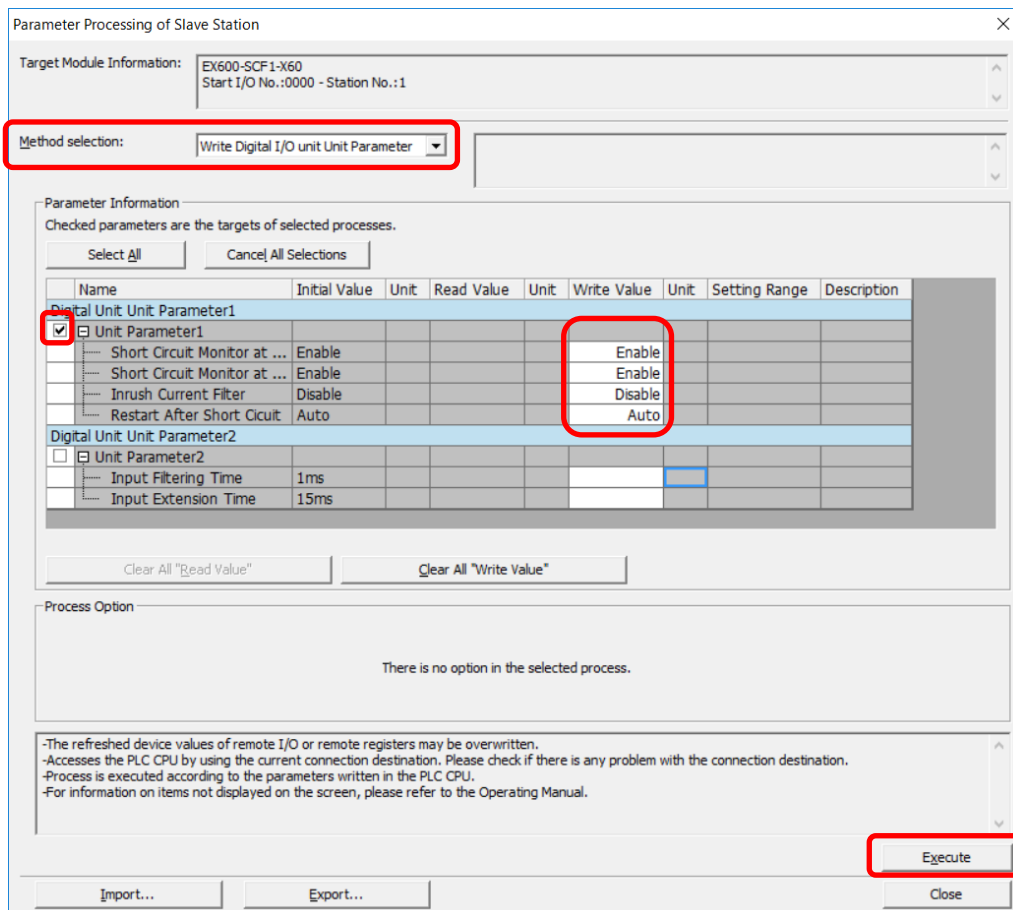

## ■Parameter setting of IO-Link device

The following service data is provided for the IO-Link device connected to the EX600-GILB.

1. Read and write device parameters
2. Read the device event data

### 【Command Execution of Skave Station】

EX600-SCF1-X60 ⇒ Online ⇒ Parameter Processing of Slave Station

The screenshot shows the 'CC IE Field Configuration Module 1 (Start I/O: 0000)' window. The main table lists the following stations:

No.	Model Name	STA#	Station Type	RX/RV Setting			RWw/RWv Setting			Refresh Device
				Points	Start	End	Points	Start	End	
0	Host Station	0	Master Station							
1	EX600-SCF1-X60	1	Intelligent Device Station	32	0000	001F	32	0000	001F	X40 (32 points)

Below the table, a network diagram shows 'STA#1' connected to the 'EX600-SCF1-X60' module. A context menu is open over this module, with the 'Online' option selected. The 'Parameter Processing of Slave Station...' option is highlighted in yellow, and the 'Command Execution of Slave Station...' option is highlighted in red.

The right-hand side of the window displays a 'Module List' with various modules, including 'EX600 Series' and 'EX600-S'. The 'Outline' section shows details for the selected module: 'EX600 Series SI unit', 'Manufacturer Name: SMC Corporation', and 'Station Type: Intelligent Device Station'.

【Specification of slot No.】

- 1) Specify the slot number of the EX600-GILB to which the IO-Link device is connected.
- 2) Method selection ⇒ Select Slot No ⇒ Slot No. Input a value from 1 to 9.
- 3) Click Executetofinishspecifying a unit from 1 to 9.

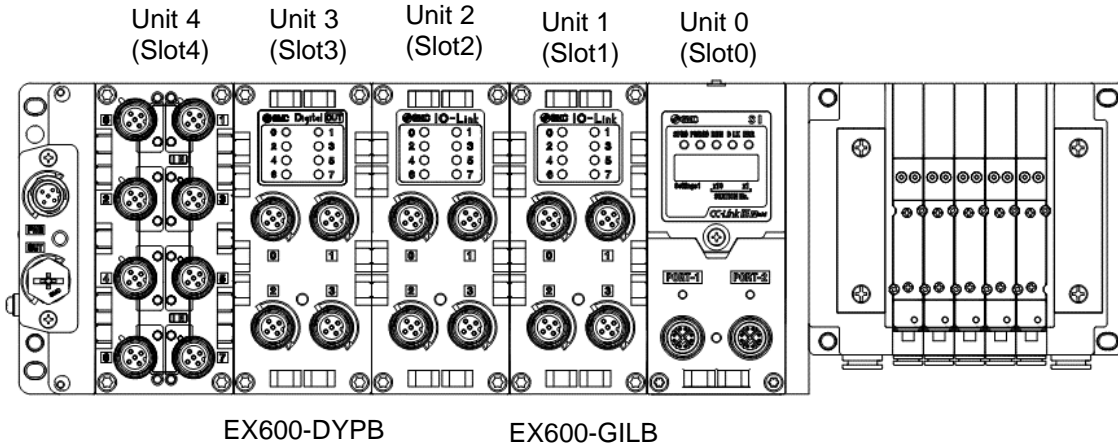

Command Execution of Slave Station

Target Module Information: EX600-SCF1-X60  
Start I/O No.:0000 - Station No.:1

Method selection: Select Slot No.

Name	Write Value	Setting Range	Unit	Description
Select Slot No.				
Slot No.	1	to 9		

Execution Result

There is no execution result in the selected process.

-The refreshed device values of remote I/O or remote registers may be overwritten.  
-Accesses the PLC CPU by using the current connection destination. Please check if there is any problem with the connection destination.  
-Process is executed according to the parameters written in the PLC CPU.  
-For information on items not displayed on the screen, please refer to the Operating Manual.

Execute

Save in the CSV file... Close

**【Read device parameters】**

It is possible to read the parameters of the IO-Link device.

1. Execute “IO-Link Device Parameter Read Request” in the following procedure.
  - 1) Enter the port number to which the IO-Link device is connected.
  - 2) Enter index and sub index according to specification of the IO-Link device.
  - 3) Press the “execute” button.

**Request to IO-Link device**

Parameter type	Content	Value
Port number.	Port number to request	1 to 4 1: Port1 2: Port2 3: Port 3 4: Port 4
Index_H	According to device specification	0x00 to 0xFF
Index_L		0x00 to 0xFF
Subindex		0x00 to 0xFF

Command Execution of Slave Station

Target Module Information: EX600-SCF1-X60  
Start I/O No.:0000 - Station No.:1

Method selection: IO-Link Device Parameter Read Reque

Name	Write Value	Setting Range	Unit	Description
IO-Link Device Parameter Read Request				
Port No.	1	1 to 4		
Index High Byte	0x00	0x00 to 0xFF		
Index Low Byte	0x01	0x00 to 0xFF		

Execution Result

There is no execution result in the selected process.

-The refreshed device values of remote I/O or remote registers may be overwritten.  
 -Accesses the PLC CPU by using the current connection destination. Please check if there is any problem with the connection destination.  
 -Process is executed according to the parameters written in the PLC CPU.  
 -For information on items not displayed on the screen, please refer to the Operating Manual.

Execute

Save in the CSV file... Close

2. Next, executing "IO-Link Device Parameter Read Response" It is possible to read specified parameters.

Response from IO-Link device

Parameter type	Content	Value
Port number.	The requested port number.	1 to 4
Index_H	The requested index No.	0x00 to 0xFF
Index_L		0x00 to 0xFF
Subindex	The requested subindex No.	0x00 to 0xFF
Read Result Status	Status of IO-Link device	0: Normal 1: Error
Read Data Size	Size of response data	0x01 to 0xE8 (0 to 232 byte)
Read Data	Response data from the device. If the status is an error, an error code is displayed	Read data

Command Execution of Slave Station

Target Module Information: EX600-SCF1-X60  
Start I/O No.:0000 - Station No.:1

Method selection: IO-Link Device Parameter Read Respo

Command Setting

There is no command setting in the selected process.

Execution Result

Name	Read Value	Unit	Description
IO-Link Device Parameter Read Response	1		
Port No.	0x00		
Index High Byte	0x18		
Index Low Byte	0x00		
Subindex	Success		
Read Result Status	32		
Read Data Size	0x2A		
Read Data0	0x2A		

-The refreshed device values of remote I/O or remote registers may be overwritten.  
 -Accesses the PLC CPU by using the current connection destination. Please check if there is any problem with the connection destination.  
 -Process is executed according to the parameters written in the PLC CPU.  
 -For information on items not displayed on the screen, please refer to the Operating Manual.

Execute

Save in the CSV file... Close

**【Write device parameters】**

It is possible to write the parameters of the IO-Link device.

1. Execute “IO-Link Device Parameter Write Request” in the following procedure.
  - 1) Enter the port number to which the IO-Link device is connected.
  - 2) Enter index and sub index according to specification of the IO-Link device.
  - 3) Enter the write data size and the write data.
  - 4) Press the “execute” button.

**Request to IO-Link device**

Parameter type	Content	Value
Port number.	Port number to request	1 to 4 1: Port1 2: Port2 3: Port 3 4: Port 4
Index_H	According to device specification	0x00 to 0xFF
Index_L		0x00 to 0xFF
Subindex		0x00 to 0xFF
Write Data Size	Size of Valid data	0x01 to 0xE8 (1 to 232 byte)
Write Data	Data for writing *1)	Data for writing

\*1: The data size for writing is always 232 bytes. Data other than valid data must be set to 0.

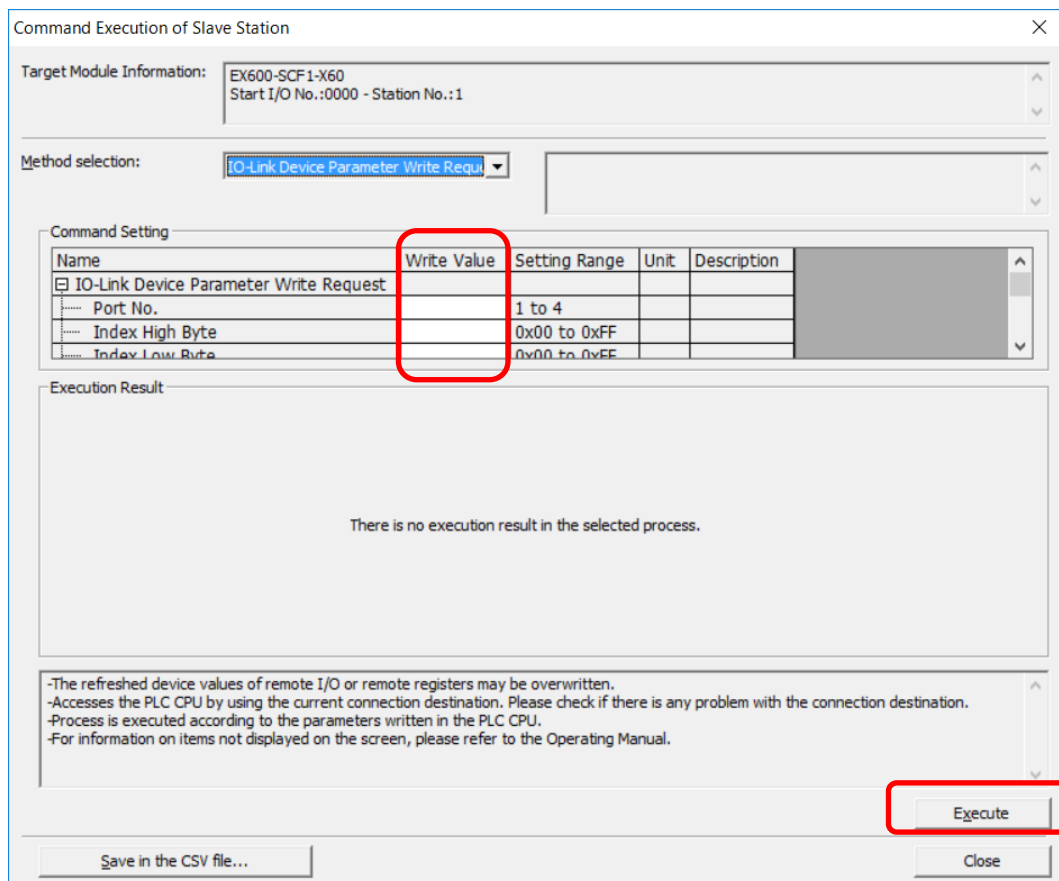

2. Next, by executing "IO-Link Device Parameter Write Response" It is possible to confirm the result of "IO-Link Device Parameter Write Reuest " .

Response from IO-Link device

Parameter type	Content	Value
Port number.	The requested port number.	1 to 4
Index_H	The requested index No.	0x00 to 0xFF
Index_L		0x00 to 0xFF
Subindex	The requested subindex No.	0x00 to 0xFF
Status	Status of IO-Link device	0: Normal 1: Error
Status Size	4	Fixed to 4
Read status data	Response data from the device. If the status is an error, an error code is displayed	According to IO-Link specification

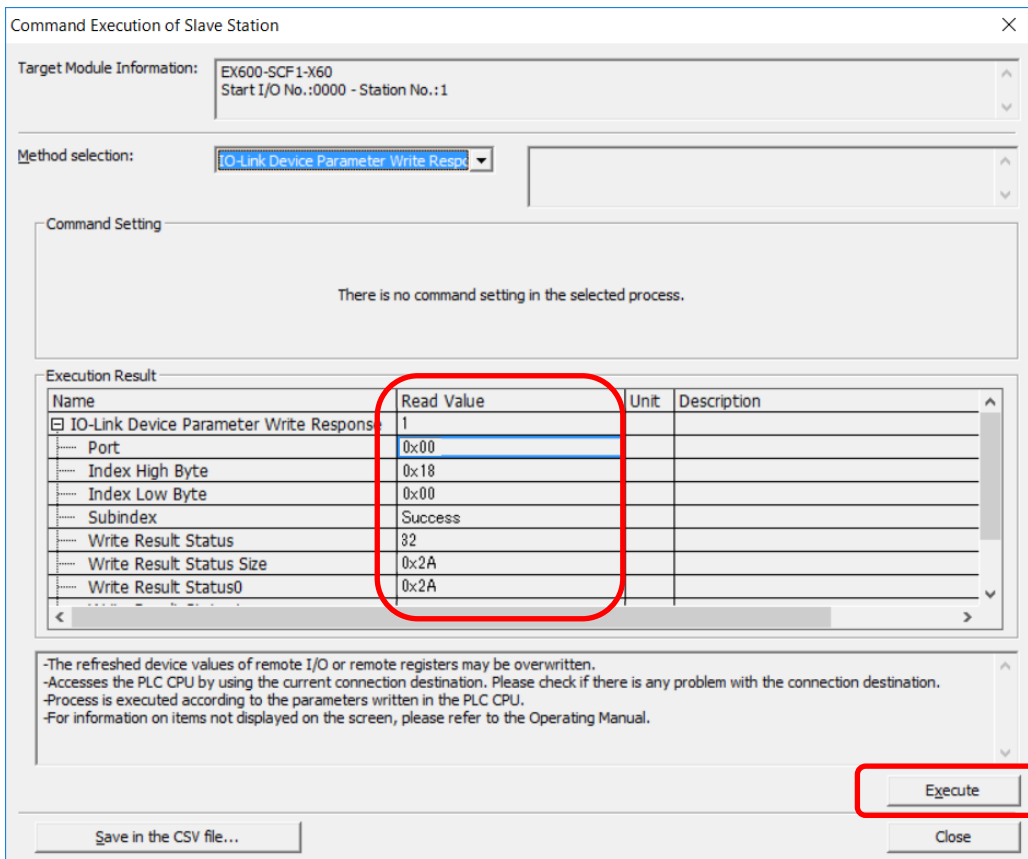



**【Read device event data】**

It is possible to read the event data of the IO-Link device by the following procedure.

- 1) Enter Port number ⇒ execute “IO-Link Device Event Data Request” .
- 2) Execute “IO-Link Device Event Data Response”.

Response event data from IO-Link device

Parameter type	Content		Value
Port number.	The requested port number.		1 to 4
Event Qualifier	Depending on the specification of the device, display mode / type / instance		According to device specification
Event Code	Display event code according to device specification		According to device specification

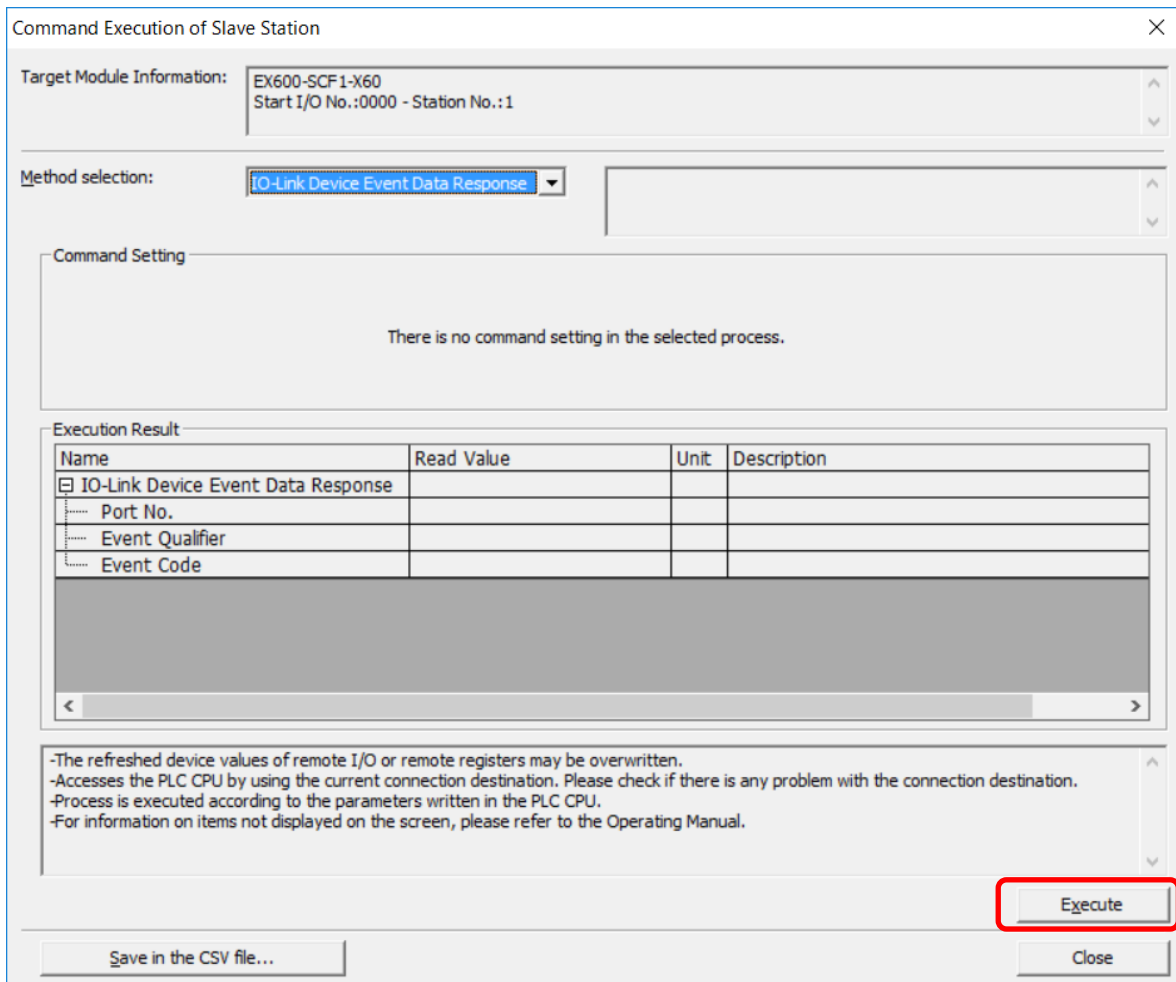

## Parameter setting with acyclic transmission

The EX600's parameters can be set using RIRD or RIWT commands.

When setting the IO unit's parameters, the relevant unit No. should be specified first under "Unit for reading/writing parameters."

There is no need to specify the unit No. when setting the same unit No.'s parameters more than once.

There is no need to specify the unit No. when setting SI unit parameters.

After specifying the relevant unit, set parameters using RIRD/RIWT commands.

### 【Structure of reading commands (RIRD)】

- When reading the data for the number of designated points from the device, enter the data below.

Data	Content	Value	Data type
Jn	Local network No.	1~239	BIN16 bit
Un	Input/output start address for the local CC-link IE Controller network units.	0~0xFE	BIN16 bit
(S+0)	Completed status 0: Normal / Value other than 0: Abnormal	—	BIN16 bit
(S+1)	Specifies the relevant station number	1~120	BIN16 bit
(S+2)	Access code: (Most significant)/Attribute code (Least significant) Access code: 0x00 (fixed) Attribute code: 0x05 (fixed)	0x0005	BIN16 bit
(S+3)	Device number *1 Start address of the device being read	1~65535	BIN16 bit
(S+4)	Read data size. Specifies the device number of the device being read (units: words)	1~480	BIN16 bit

\*1 See below for list of device numbers.

### 【Structure of writing commands (RIWT)】

- When writing data for the number of designated points to the device, enter the data below.

Data	Content	Value	Data type
Jn	Local network No.	1~239	BIN16 bit
Un	Input/output start address for the local CC-Link IE controller network units	0~0xFE	BIN16 bit
(S+0)	Completed status 0: Normal / Value other than 0: Abnormal	—	BIN16 bit
(S+1)	Specifies the relevant station number	1~120	BIN16 bit
(S+2)	Access code: (Most significant)/Attribute code (Least significant) Access code: 0x00 (fixed) Attribute code: 0x05 (fixed)	0x0005	BIN16 bit
(S+3)	Device number *1 Start address of the device being written	1~65535	BIN16 bit
(S+4)	Number of points written Specifies the data amount for the device number being written (units: words)	1~480	BIN16 bit

\*1 See below for list of device numbers

## ■ Parameter setting of EX600

### 【Selecting unit for reading/writing parameters】

Specifies a unit on which to carry out parameter reading/writing using RIWT.

Device No.	Parameter type	Content	Value	Size (Words)
0x0090	Specifies unit No.	Byte1: 0 Byte0: Unit No.	1 to 9	1

### 【Device numbers】

The device numbers of the parameters for each unit are shown below.

#### SI unit device number(1)

Device No.	Parameter type	Content	Value	Size (Words)
0x0050	Network number setting	Byte1: 0 Byte0: Network number	1 to 239	1
0x0100	Unit parameter 1	Bit15: Reserve	0	1
		Bit14: Short circuit detection	0:disable, 1:enable	
		Bit5-13: Reserve	0	
		Bit4: Restart after short circuit	0:Manual, 1:Auto	
0x0101	Unit parameter 2	Bit3-15: Reserve	0	1
		Bit2: Hold/Clear	0: via switch, 1: via software	
		Bit1: Power supply for output voltage monitor	0: disable, 1: enable	
		Bit0: Power supply for control and input voltage monitor	0: disable, 1: enable	
0x0102	CH0-CH15 Valve ON/OFF counter	Bit15: CH15 : Bit0: CH0	0: disable, 1: enable	1
0x0103	CH0-CH15 Open circuit detection	Bit15: CH15 : Bit0: CH0	0: disable, 1: enable	1
0x0104	CH0-CH15 Output setting during communication fault	Bit15: CH15 : Bit0: CH0	0: disable, 1: enable	1
0x0105	CH0-CH15 Output value during communication fault	Bit15: CH15 : Bit0: CH0	0: clear, 1: force ON	1
0x0106	CH0-CH15 Output setting during communication idle	Bit15: CH15 : Bit0: CH0	0:disable, 1:enable	1
0x0107	CH0-CH15 Output value during communication idle	Bit15: CH15 : Bit0: CH0	0: clear, 1: force ON	1

SI unit device number (2)

Device No.	Parameter type	Content	Value	Size (Words)
0x0108	CH16-31 Valve ON/OFF counter	Bit15: CH31 : Bit0: CH16	0: disable, 1: enable	1
0x0109	CH16-31 Open circuit detection	Bit15: CH31 : Bit0: CH16	0: disable, 1: enable	1
0x010A	CH16-31 Output setting during communication fault	Bit15: CH31 : Bit0: CH16	0: disable, 1: enable	1
0x010B	CH16-31 Output value during communication fault	Bit15: CH31 : Bit0: CH16	0: clear, 1: force ON	1
0x010C	CH16-31 Output setting during communication idle	Bit15: CH31 : Bit0: CH16	0: clear, 1: force ON	1
0x010D	CH16-31 Output value during communication idle	Bit15: CH31 : Bit0: CH16	0:OFF 1:ON	1
0x0140	CH0 ON/OFF counter limit value	CH0 limit value	1 to 65,000 (x 1,000 times)	1
0x0141	CH1 ON/OFF counter limit value	CH1 limit value		1
:	:	:		:
0x015E	CH30 ON/OFF counter limit value	CH30 limit value		1
0x015F	CH31 ON/OFF counter limit value	CH31 limit value		1
0x01C0	CH0 ON/OFF counter value (read only)	CH0 counter value	1 to 4,294,967,295	2
0x01C1	CH1 ON/OFF counter value (read only)	CH1 counter value		2
:	:	:		:
0x01FD	CH30 ON/OFF counter value (read only)	CH30 counter value		2
0x01FE	CH31 ON/OFF counter value (read only)	CH31 counter value		2
0x02C0	CH0-CH31 ON/OFF counter value clear (write only)	Bit31: CH31 : Bit0: CH0	1: clear	2

Digital input unit device number

Device No.	Parameter type	Content	Value	Size (Words)
0x0300	Unit parameter 1	Bit15: Short circuit detection	0:disable,1:enable	1
		Bit8-14: Reserve	0	
		Bit7: Inrush current filter	0:disable,1:enable	
		Bit0-6: Reserve	0	
0x0301	Unit parameter2	Bit10-15: Reserve	0	1
		Bit8-9: Input extension time	0: 1ms, 1: 15ms, 2:100ms, 3:200ms	
		Bit2-7: Reserve	0	
		Bit0-1: Input filtering time	0: 0.1ms, 1: 1ms, 2: 10ms, 3: 20ms	
0x0302	CH0-15 ON/OFF counter	Bit15: CH15 : Bit0: CH0	0:disable,1:enable	1
0x0303	CH0-15 Open circuit detection	Bit15: CH15 : Bit0: CH0	0:disable,1:enable	1
0x0310	CH0 ON/OFF counter limit value	CH0 limit value	1 to 65,000 (x 1,000 times)	1
:	:	:		:
0x031F	CH15 ON/OFF counter limit value	CH15 limit value		1
0x0330	CH0 ON/OFF counter value (read only)	CH0 counter value	1 to 4,294,967,295	2
:	:	:		:
0x034E	CH15 ON/OFF counter value (read only)	CH15 counter value		2
0x0370	CH0-CH15 ON/OFF counter value clear (write only)	Bit15: CH15 : Bit0: CH0	1: clear	1

Digital output unit device number

Device No.	Parameter type	Content	Value	Size (Words)
0x0300	Unit parameter 1	Bit15: Reserve	0	1
		Bit14: Short circuit detection	0:disable, 1:enable	
		Bit5-13: Reserve	0	
		Bit4: Restart after short circuit	0:Manual, 1:Auto	
		Bit0-3: Reserve	0	
0x0302	CH0-CH15 ON/OFF counter	Bit15: CH15 : Bit0: CH0	0: disable, 1: enable	1
0x0303	CH0-CH15 Open circuit detection	Bit15: CH15 : Bit0: CH0	0: disable, 1: enable	1
0x0304	CH0-CH15 Output setting during communication fault	Bit15: CH15 : Bit0: CH0	0: disable, 1: enable	1
0x0305	CH0-CH15 Output value during communication fault	Bit15: CH15 : Bit0: CH0	0: clear, 1: force ON	1
0x0306	CH0-CH15 Output setting during communication idle	Bit15: CH15 : Bit0: CH0	0:disable, 1:enable	1
0x0307	CH0-CH15 Output value during communication idle	Bit15: CH15 : Bit0: CH0	0: clear, 1: force ON	1
0x0310	CH0 ON/OFF counter limit value	CH0 limit value	1 to 65,000 (x 1,000 times)	1
:	:	:		:
0x031F	CH15 ON/OFF counter limit value	CH15 limit value		1
0x0330	CH0 ON/OFF counter value (read only)	CH0 counter value	1 to 4,294,967,295	2
:	:	:		:
0x034E	CH15 ON/OFF counter value (read only)	CH15 counter value		2
0x0370	CH0-CH15 ON/OFF counter value clear (write only)	Bit15: CH15 : Bit0: CH0	1: clear	1

Digital input/output unit device number

Device No.	Parameter type	Content	Value	Size (Words)
0x0300	Unit parameter 1 (Bit7,15: digital input only) (Bit4,14: digital output only)	Bit15: Short circuit detection (digital input side)	0:disable,1:enable	1
		Bit14: Short circuit detection (digital output side)	0:disable,1:enable	
		Bit8-13: Reserve	0	
		Bit7: Inrush current filter	0:disable,1:enable	
		Bit5-6: Reserve	0	
		Bit4: Restart after short circuit	0:Manual, 1:Auto	
		Bit0-3: Reserve	0	
0x0301	Unit parameter 2 (digital input only)	Bit10-15: Reserve	0	1
		Bit8-9: Input extension time	0: 1ms, 1: 15ms, 2:100ms, 3:200ms	
		Bit2-7: Reserve	0	
		Bit0-1: Input filtering time	0: 0.1ms, 1: 1ms, 2: 10ms, 3: 20ms	
0x0302	CH0-CH15 ON/OFF counter	Bit15: CH15 : Bit0: CH0	0: disable, 1: enable	1
0x0303	CH0-CH15 Open circuit detection	Bit15: CH15 : Bit0: CH0	0: disable, 1: enable	1
0x0304	CH0-CH15 Output setting during communication fault (digital output only)	Bit15: CH15 : Bit0: CH0	0: disable, 1: enable	1
0x0305	CH0-CH15 Output value during communication fault (digital output only)	Bit15: CH15 : Bit0: CH0	0: clear, 1: force ON	1
0x0306	CH0-CH15 Output setting during communication idle (digital output only)	Bit15: CH15 : Bit0: CH0	0:disable,1:enable	1
0x0307	CH0-CH15 Output value during communication idle (digital output only)	Bit15: CH15 : Bit0: CH0	0: clear, 1: force ON	1
0x0310	CH0 ON/OFF counter limit value	CH0 limit value	1 to 65,000 (x 1,000 times)	1
:	:	:		:
0x031F	CH15 ON/OFF counter limit value	CH15 limit value		1
0x0330	CH0 ON/OFF counter value (read only)	CH0 counter value	1 to 4,294,967,295	2
:	:	:		:
0x034E	CH15 ON/OFF counter value (read only)	CH15 counter value		2
0x0370	CH0-CH15 ON/OFF counter value clear (write only)	Bit15: CH15 : Bit0: CH0	1: clear	1

Analog input unit device number (EX600-AXA)

Device No.	Parameter type	Content	Value	Size (Words)
0x0380	Unit parameter 1	Bit15: Short circuit detection	0:disable,1:enable	1
		Bit12-14: Reserve	0	
		Bit11: Over range detection	0:disable,1:enable	
		Bit10: Under range detection	0:disable,1:enable	
		Bit0-9: Reserve	0	
0x0381	Unit parameter 2	Bit2-15: Reserve	0	1
		Bit0-1: Analog data format	0: Offset binary 1: Signed binary 2: 2's complement	
0x0382	CH0-CH1 Analog input range	Bit8-15: Reserve	0	1
		Bit4-7: CH1 Bit0-3: CH0	0: ±10V, 1: ±5V, 2: ±20mA, 3: 0..10V, 4: 0..5V, 5: 1..5V, 6: 0..20mA, 7: 4..20mA	
0x0383	CH0-CH1 Analog average filter	Bit8-15: Reserve	0	1
		Bit4-7: CH1 Bit0-3: CH0	0: None 1: 2 average filter, 2: 4 average filter, 3: 8 average filter	
0x0384	CH0-CH1 User setting value upper limit error	Bit8-15: Reserve	0	1
		Bit4-7: CH1 Bit0-3: CH0	0:disable,1:enable	
0x0385	CH0-CH1 User setting value lower limit error	Bit8-15: Reserve	0	1
		Bit4-7: CH1 Bit0-3: CH0	0:disable,1:enable	
0x0388	CH0 User setting upper limit value	CH0 User setting upper limit value	Refer to "Parameter setting".	1
0x0389	CH1 User setting upper limit value	CH1 User setting upper limit value		1
0x038C	CH0 User setting lower limit value	CH0 User setting lower limit value	Refer to "Parameter setting".	1
0x038D	CH1 User setting lower limit value	CH1 User setting lower limit value		1



Analog output unit device number (EX600-AYA)

Device No.	Parameter type	Content	Value	Size (Words)
0x0380	Unit parameter 1	Bit15: Short circuit detection	0:disable,1:enable	1
		Bit12-14: Reserve	0	
		Bit11: Over range detection	0:disable,1:enable	
		Bit10: Under range detection	0:disable,1:enable	
		Bit0-9: Reserve	0	
0x0381	Unit parameter 2	Bit2-15: Reserve	0	1
		Bit0-1: Analog data format	0: Offset binary 1: Signed binary 2: 2's complement 3: Scaled	
0x0382	CH0-CH1 Analog output range	Bit8-15: Reserve	0	1
		Bit7-4: CH1 Bit3-0: CH0	3: 0..10V 4: 0..5V 5: 1..5V 6: 0..20mA 7: 4..20mA	
0x0384	CH0-CH1 User setting value upper limit error	Bit8-15: Reserve	0	1
		Bit7-4: CH1 Bit3-0: CH0	0: disable, 1: enable	
0x0385	CH0-CH1 User setting value lower limit error	Bit8-15: Reserve	0	1
		Bit7-4: CH1 Bit3-0: CH0	0: disable, 1: enable	
0x0386	CH0-CH1 Output setting for communication error *1	Bit8-15: Reserve	0	1
		Bit7-4: CH1 Bit3-0: CH0	0: disable, 1: enable	
0x0387	CH0-CH1 Output setting for communication idling *1	Bit8-15: Reserve	0	1
		Bit7-4: CH1 Bit3-0: CH0	0: disable, 1: enable	
0x0388	CH0 User setting upper limit value or scale upper limit value	CH0 User setting upper limit value or scale upper limit value	Refer to "Parameter setting".	1
0x0389	CH1 User setting upper limit value or scale upper limit value	CH1 User setting upper limit value or scale upper limit value		1
0x038C	CH0 User setting lower limit value or scale lower limit value	CH0 User setting lower limit value or scale lower limit value	Refer to "Parameter setting".	1
0x038D	CH1 User setting lower limit value or scale lower limit value	CH1 User setting lower limit value or scale lower limit value		1
0x0390	CH0 Output value for communication error	CH0 Output value for communication error	Refer to "Parameter setting".	1
0x0391	CH1 Output value for communication error	CH1 Output value for communication error		1
0x0394	CH0 Output value for communication idling	CH0 Output value for communication idling	Refer to "Parameter setting".	1
0x0395	CH1 Output value for communication idling	CH1 Output value for communication idling		1

\*1: This function is valid only when "Hold/Clear priority" of the system parameter is set to "Via software".

Analog input/output unit device number (1) (EX600-AMB)

Device No.	Parameter type	Content	Value	Size (Words)
0x0380	Unit parameter 1	Bit15: Short circuit detection	0:disable,1:enable	1
		Bit11: Over range detection	0:disable,1:enable	
		Bit10: Under range detection	0:disable,1:enable	
0x0381	Unit parameter 2	Bit0-1: Analog data format	0: Offset binary 1: Signed binary 2: 2's complement 3: Scaled	1
0x0382	CH0-CH3 Analog input/output range	Bit14-12: CH3 Bit10-8: CH2 Bit6-4: CH1 Bit2-0: CH0	3: 0..10V 4: 0..5V 5: 1..5V 6: 0..20mA 7: 4..20mA	1
0x0383	CH0-CH1 Analog average filter (analog input only)	Bit5-4: CH1 Bit1-0: CH0	0: None 1: 2 average filter, 2: 4 average filter, 3: 8 average filter	1
0x0384	CH0-CH3 User setting value upper limit error	Bit12: CH3 Bit8: CH2 Bit4: CH1 Bit0: CH0	0: disable, 1: enable	1
0x0385	CH0-CH3 User setting value lower limit error	Bit12: CH3 Bit8: CH2 Bit4: CH1 Bit0: CH0	0: disable, 1: enable	1
0x0386	CH2-CH3 Output setting for communication error *1 (analog output only)	Bit12: CH3 Bit8: CH2	0: disable, 1: enable	1
0x0387	CH2-CH3 Output setting for communication idling *1 (analog output only)	Bit12: CH3 Bit8: CH2	0: disable, 1: enable	1
0x0388	CH0 User setting upper limit value or scale upper limit value	CH0 User setting upper limit value or scale upper limit value	Refer to Parameter setting of analog unit	1
0x0389	CH1 User setting upper limit value or scale upper limit value	CH1 User setting upper limit value or scale upper limit value		1
0x038A	CH2 User setting upper limit value or scale upper limit value	CH2 User setting upper limit value or scale upper limit value		1
0x038B	CH3 User setting upper limit value or scale upper limit value	CH3 User setting upper limit value or scale upper limit value		1
0x038C	CH0 User setting lower limit value or scale lower limit value	CH0 User setting lower limit value or scale lower limit value	Refer to Parameter setting of analog unit	1
0x038D	CH1 User setting lower limit value or scale lower limit value	CH1 User setting lower limit value or scale lower limit value		1
0x038E	CH2 User setting lower limit value or scale lower limit value	CH2 User setting lower limit value or scale lower limit value		1
0x038F	CH3 User setting lower limit value or scale lower limit value	CH3 User setting lower limit value or scale lower limit value		1

Analog input/output unit device number (2)

Device No.	Parameter type	Content	Value	Size (Words)
0x0392	CH2 Output value for communication error	CH2 Output value for communication error	Refer to Parameter setting of analog unit	1
0x0393	CH3 Output value for communication error	CH3 Output value for communication error		1
0x0396	CH2 Output value for communication idling	CH2 Output value for communication idling	Refer to Parameter setting of analog unit	1
0x0397	CH3 Output value for communication idling	CH3 Output value for communication idling		1

\*1: This function is valid only when "Hold/Clear priority" of the system parameter is set to "Via software".

IO-Link Master unit device number (1) (EX600-GILB)

It is necessary to execute "Port parameter write confirmation command" after setting the port parameters. If it is not executed, the parameter is not reflected

Device No.	Parameter type	Content	Value	Size (Words)
0x0400	Unit parameter	Bit15: Short circuit detection	0:disable, 1:enable	1
0x0401	Port parameter ( Pin 4 mode setting )	Bit12-13 : PORT4 Bit8-9 : PORT3 Bit4-5 : PORT2 Bit0-1 : PORT1	0 : Inactive 1 : IO-Link 2 : Input 3 : Output	1
0x0402	Port parameter ( Validation mode )	Bit12 : PORT4 Bit8 : PORT3 Bit4 : PORT2 Bit0 : PORT1	0:No Check 1:Compatible	1
0x0403	Port parameter ( Data storage )	Bit12-13 : PORT4 Bit8-9 : PORT3 Bit4-5 : PORT2 Bit0-1 : PORT1	0:Disable 1:Restore 2:Backup/Restore	1
0x0404	Port parameter ( Process data format of input data )	PORT1_IN	Bit12: Byte order of process data (0:disable, 1:enable)	1
0x0405		PORT2_IN		1
0x0406		PORT3_IN	Bit0-4: Process data size (1 to 32byte)	1
0x0407		PORT4_IN		1
0x0408	Port parameter ( Process data format of output data )	PORT1_OUT	B Bit12: Byte order of process data (0:disable, 1:enable)	1
0x0409		PORT2_OUT		1
0x040A		PORT3_OUT	Bit0-4: Process data size (1 to 32byte)	1
0x040B		PORT4_OUT		1

IO-Link Master unit device number (2)

Device No.	Parameter type	Content	Value	Size (Words)
0x040C	Port parameter ( Cycle time)	PORT1	0 to 1328 ( 0 to 132.8 ms )	1
0x040D		PORT2		1
0x040E		PORT3		1
0x040F		PORT4		1
0x0410	Port parameter ( Vendor ID)	PORT1	0 to 0XFFFF	1
0x0411		PORT2		1
0x0412		PORT3		1
0x0413		PORT4		1
0x0414	Port parameter ( Device ID)	Device ID PORT1_H	ex. Device ID :0x567890 ⇒ PORT_H: 0x0056 PORT_L: 0x7890	2
0x0416		Device ID PORT1_L		2
		Device ID PORT2_H		2
0x0418		Device ID PORT2_L		2
		Device ID PORT3_H		2
0x041A		Device ID PORT3_L		2
		Device ID PORT4_H	2	
		Device ID PORT4_L	2	

Port parameter write confirmation command

Device No.	Parameter type	Content	Value	Size (Words)
0x05D0	Port parameter write confirmation command	Confirm write parameter	1: Confirm	1

## ■Parameter setting of IO-Link device

### 【ISDU】

It is possible to read and write service data of IO-Link device using ISDU.

### 【Read parameter】

By executing "Response from IO-Link device" after "Request to IO-Link device", it is possible to read specified parameters.

#### Request to IO-Link device

Device No.	Parameter type	Content	Value	Size (Words)
0x0490	Port number (Lower byte of word 0)	Port number to request	1 to 4	2
	Index_H (Upper byte of word 0)	According to device specification	0x00 to 0xFF	
	Index_L (Lower byte of word 1)	According to device specification	0x00 to 0xFF	
	SubIndex (Upper byte of word 1)	According to device specification	0x00 to 0xFF	

#### Response from IO-Link device

Device No.	Parameter type	Content	Value	Size (Words)
0x04A0	Port number (Lower byte of word 0)	Port number to request	1 to 4	119
	Index_H (Upper byte of word 0)	According to device specification	0x00 to 0xFF	
	Index_L (Lower byte of word 1)	According to device specification	0x00 to 0xFF	
	SubIndex (Upper byte of word 1)	According to device specification	0x00 to 0xFF	
	Status (Lower byte of word 2)	Status of IO-Link device	0: Normal 1: Error	
	Data size (Upper byte of word 2)	Size of response data	0x000 to 0x00E8 (0 to 232 byte)	
	Read_data (Lower byte of word 3 to word ## )	Response data from the device. If the status is an error, an error code is displayed	Read data	

**【Write parameter】**

By executing "Response from IO-Link device" after "Request to IO-Link device", it is possible to write specified parameters.

**Request to IO-Link device**

Device No.	Parameter type	Content	Value	Size (Words)
0x0520	Port number (Lower byte of word 0)	Port number to request	1 to 4	119
	Index_H (Upper byte of word 0)	According to device specification	0x00 to 0xFF	
	Index_L (Lower byte of word 1)	According to device specification	0x00 to 0xFF	
	SubIndex (Upper byte of word 1)	According to device specification	0x00 to 0xFF	
	Data size (Upper byte of word 2)	Size of Valid data	0x01 to 0xE8 (1 to 232byte)	
	Write_data *1 (Upper byte of word 2 to word 231)	Data for writing	Data for writing	

\*1: The writing data size is always 232 bytes. Data other than valid data must be set to 0.

**Response from IO-Link device**

Device No.	Parameter type	Content	Value	Size (Words)
0x05A0	Port number (Lower byte of word 0)	Port number to request	1 to 4	5
	Index_H (Upper byte of word 0)	The specified index	0x00 to 0xFF	
	Index_L (Lower byte of word 1)	The specified index	0x00 to 0xFF	
	SubIndex (Upper byte of word 1)	The specified subindex	0x00 to 0xFF	
	Status (Lower byte of word 2)	Status of IO-Link device	0: Normal 1: Error	
	Status size (Upper byte of word 2)	4	Fixed to 4	
	Read_status_data (word 3 to word 4)	Response data from the device. If the status is an error, an error code is displayed	According to IO-Link specification	

**【Event code】**

It is possible to read the event data from IO-Link device.

Request event data to IO-Link device

Device No.	Parameter type	Content	Value	Size (Words)
0x05B0	Port number	Port number to request	1 to 4	1
	Reserve	-	-	

Response event data from IO-Link device

Device No.	Parameter type	Content	Value	Size (Words)
0x05C0	Port number	Port number to request	1 to 4	2
	Event qualifier	Bit6-7: Mode	1: Event single shot 2: Event disappears 3: Event appears	
		Bit4-5: Type	1: Notification 2: Warning 3: Error	
		Bit3: Source	0: Device(remote) 1: Master(local)	
		Bit0-2: Instance	0: Unknown 1-3: Reserved 4: Appliation 5-7: reserved	
	Event code_H	According to device specification	-	
	Event code_L	According to device specification	-	



## Accessories

For the selection of accessories, refer to the catalog.

### (1) Valve plate

#### EX600-ZMV1

Enclosed parts: Round head screw (M4 x 6), 2 pcs.  
Round head screw (M3 x 8), 4 pcs.

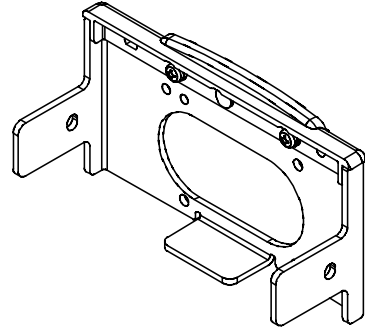

#### EX600-ZMV2 (Specified for SY series)

Enclosed parts: Round head screw (M4 x 6), 2 pcs.  
Round head screw (M3 x 8), 4 pcs.

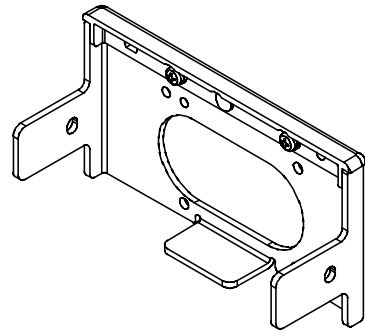

### (2) End plate bracket

#### EX600-ZMA2

Enclosed parts: Round head screw (M4 x 20), 1 pc.  
P tight screw (4 x 14), 2 pcs.

#### EX600-ZMA3 (Specified for SY series)

Enclosed parts: Round head screw (M4x20) with washer, 1 pc.  
P tight screw (4 x 14), 2 pcs.

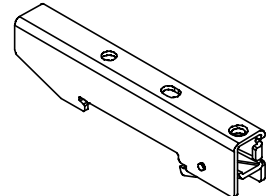

### (3) Intermediate support bracket

#### EX600-ZMB1: For direct mounting

Enclosed parts: Round head screw (M4 x 5), 2 pcs.

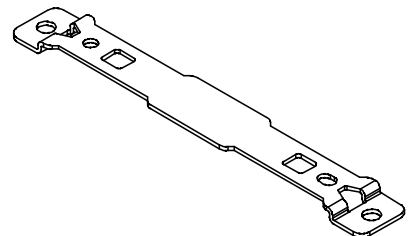

#### EX600-ZMB2: For DIN rail mounting

Enclosed parts: Round head screw (M4 x 6), 2 pcs.

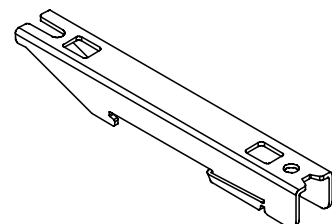

(4) Seal cap (10 pcs.)

EX9-AWES: For M8  
EX9-AWTS: For M12

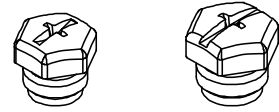

(5) Marker (1 sheet, 88 pcs.)

EX600-ZT1

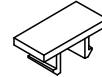

(6) Assembled type connector

PCA-1578078: For power supply, 7/8 inch, Plug, Cable O.D. 12 to 14 mm

PCA-1578081: For power supply, 7/8 inch, Socket, Cable O.D. 12 to 14 mm

(7) Power supply cable

PCA-1558810: Cable with 7/8 inch connector, Socket, Straight 2 m

PCA-1558823: Cable with 7/8 inch connector, Socket, Straight 6 m

PCA-1558836: Cable with 7/8 inch connector, Socket, Right angle 2 m

PCA-1558849: Cable with 7/8 inch connector, Socket, Right angle 6 m

PCA-1564927: Cable with M12 connector, B code, Socket, Straight 2 m, SPEEDCON compatible

PCA-1564930: Cable with M12 connector, B code, Socket, Straight 6 m, SPEEDCON compatible

PCA-1564943: Cable with M12 connector, B code, Socket, Right angle 2 m, SPEEDCON compatible

PCA-1564969: Cable with M12 connector, B code, Socket, Right angle 6 m, SPEEDCON compatible

Revision history

## SMC Corporation

4-14-1, Sotokanda, Chiyoda-ku, Tokyo 101-0021 JAPAN

Tel: +81 3 5207 8249 Fax: +81 3 5298 5362

URL <http://www.smcworld.com>

---

Note: Specifications are subject to change without prior notice and any obligation on the part of the manufacturer.

EtherNet/IP™ is a trademark of ODVA

The descriptions of products shown in this document may be used by the other companies as their trademarks.

© 2018 SMC Corporation All Rights Reserved

