



# Operation Manual

PRODUCT NAME

EtherNet/IP™ Compatible Fieldbus System

MODEL / Series / Product Number

*EX500-GEN2*

*EX500-S103*

*EX500-DXPA*

**SMC Corporation**

## Table of Contents

Safety Instructions	3
Product Overview	9
System construction	9
<b>EX500 GW unit</b>	
Model Indication and How to Order	10
Summary of Product parts	10
Mounting and Installation	11
Installation	11
Wiring	12
LED Display	17
Setting of EtherNet/IP™ using RSLogix5000™	20
I/O memory map	22
Web server function	30
Specification	39
Specifications	39
Dimensions	41
<b>SI unit</b>	
Model Indication and How to Order	42
Summary of Product parts	42
Mounting and Installation	43
Installation	43
Separate power supply	46
LED Display and Settings	47
Specification	48
Specifications	48
Dimensions	49



## ***Input unit***

Model Indication and How to Order	50
Summary of Product parts	50
Mounting and Installation	51
Installation	51
Wiring	52
LED Display	55
Specification	56
Specifications	56
Dimensions	57
Interchangeability of system	58
Troubleshooting	62
Accessories	69

## Safety Instructions

These safety instructions are intended to prevent hazardous situations and/or equipment damage. These instructions indicate the level of potential hazard with the labels of "Caution", "Warning" or "Danger". They are all important notes for safety and must be followed in addition to International standards (ISO/IEC) \*1) and other safety regulations.

- \*1) ISO 4414: Pneumatic fluid power -- General rules relating to systems
- ISO 4413: Hydraulic fluid power -- General rules relating to systems
- IEC 60204-1: Safety of machinery -- Electrical equipment of machines (Part 1: General requirements)
- ISO 10218-1992: Manipulating industrial robots -Safety.
- etc.

-  **Caution** : CAUTION indicates a hazard with a low level of risk which, if not avoided, could result in minor or moderate injury.
-  **Warning** : WARNING indicates a hazard with a medium level of risk which, if not avoided, could result in death or serious injury.
-  **Danger** : DANGER indicates a hazard with a high level of risk which, if not avoided, will result in death or serious injury.

### Warning

**1. The compatibility of the product is the responsibility of the person who designs the equipment or decides its specifications.**

Since the product specified here is used under various operating conditions, its compatibility with specific equipment must be decided by the person who designs the equipment or decides its specifications based on necessary analysis and test results. The expected performance and safety assurance of the equipment will be the responsibility of the person who has determined its compatibility with the product. This person should also continuously review all specifications of the product referring to its latest catalog information, with a view to giving due consideration to any possibility of equipment failure when configuring the equipment.

**2. Only personnel with appropriate training should operate machinery and equipment.**

The product specified here may become unsafe if handled incorrectly. The assembly, operation and maintenance of machines or equipment including our products must be performed by an operator who is appropriately trained and experienced.

**3. Do not service or attempt to remove product and machinery/equipment until safety is confirmed.**

1. The inspection and maintenance of machinery/equipment should only be performed after measures to prevent falling or runaway of the driven objects have been confirmed.
2. When the product is to be removed, confirm that the safety measures as mentioned above are implemented and the power from any appropriate source is cut, and read and understand the specific product precautions of all relevant products carefully.
3. Before machinery/equipment is restarted, take measures to prevent unexpected operation and malfunction.

**4. Contact SMC beforehand and take special consideration of safety measures if the product is to be used in any of the following conditions.**

1. Conditions and environments outside of the given specifications, or use outdoors or in a place exposed to direct sunlight.
2. Installation on equipment in conjunction with atomic energy, railways, air navigation, space, shipping, vehicles, military, medical treatment, combustion and recreation, or equipment in contact with food and beverages, emergency stop circuits, clutch and brake circuits in press applications, safety equipment or other applications unsuitable for the standard specifications described in the product catalog.
3. An application which could have negative effects on people, property, or animals requiring special safety analysis.
4. Use in an interlock circuit, which requires the provision of double interlock for possible failure by using a mechanical protective function, and periodical checks to confirm proper operation.

## Caution

### **The product is provided for use in manufacturing industries.**

The product herein described is basically provided for peaceful use in manufacturing industries. If considering using the product in other industries, consult SMC beforehand and exchange specifications or a contract if necessary.  
If anything is unclear, contact your nearest sales branch.

## **Limited warranty and Disclaimer/Compliance Requirements**

The product used is subject to the following "Limited warranty and Disclaimer" and "Compliance Requirements".

Read and accept them before using the product.

### **Limited warranty and Disclaimer**

1. The warranty period of the product is 1 year in service or 1.5 years after the product is delivered, whichever is first. \*2)  
Also, the product may have specified durability, running distance or replacement parts. Please consult your nearest sales branch.
2. For any failure or damage reported within the warranty period which is clearly our responsibility, a replacement product or necessary parts will be provided.  
This limited warranty applies only to our product independently, and not to any other damage incurred due to the failure of the product.
3. Prior to using SMC products, please read and understand the warranty terms and disclaimers noted in the specified catalog for the particular products.

\*2) Vacuum pads are excluded from this 1 year warranty.

A vacuum pad is a consumable part, so it is warranted for a year after it is delivered.

Also, even within the warranty period, the wear of a product due to the use of the vacuum pad or failure due to the deterioration of rubber material are not covered by the limited warranty.

### **Compliance Requirements**

1. The use of SMC products with production equipment for the manufacture of weapons of mass destruction (WMD) or any other weapon is strictly prohibited.
2. The exports of SMC products or technology from one country to another are governed by the relevant security laws and regulation of the countries involved in the transaction. Prior to the shipment of a SMC product to another country, assure that all local rules governing that export are known and followed.

## Operator

- ◆ This operation manual is intended for those who have knowledge of machinery using pneumatic equipment, and have sufficient knowledge of assembly, operation and maintenance of such equipment. Only those persons are allowed to perform assembly, operation and maintenance.
- ◆ Read and understand this operation manual carefully before assembling, operating or providing maintenance to the product.

### ■ Safety Instructions

#### **Warning**

- Do not disassemble, modify (including changing the printed circuit board) or repair.  
An injury or failure can result.
- Do not operate the product outside of the specifications.  
Do not use for flammable or harmful fluids.  
Fire, malfunction, or damage to the product can result.  
Verify the specifications before use.
- Do not operate in an atmosphere containing flammable or explosive gases.  
Fire or an explosion can result.  
This product is not designed to be explosion proof.
- If using the product in an interlocking circuit:
  - Provide a double interlocking system, for example a mechanical system.
  - Check the product regularly for proper operation.Otherwise malfunction can result, causing an accident.
- The following instructions must be followed during maintenance:
  - Turn off the power supply.
  - Stop the air supply, exhaust the residual pressure and verify that the air is released before performing maintenance.Otherwise an injury can result.

## Caution

- After maintenance is complete, perform appropriate functional inspections.  
Stop operation if the equipment does not function properly.  
Safety cannot be assured in the case of unexpected malfunction.
- Provide grounding to assure the safety and noise resistance of the Serial System.  
Individual grounding should be provided close to the product with a short cable.

### ■ NOTE

- Follow the instructions given below when designing, selecting and handling the product.
- The instructions on design and selection (installation, wiring, environment, adjustment, operation, maintenance, etc.) described below must also be followed.
- \*Product specifications
  - The direct current power supply to combine should be UL1310 Class 2 power supply when conformity to UL is necessary.
  - The product is a UL approved product only if they have a  mark on the body.
  - Use the specified voltage.  
Otherwise failure or malfunction can result.
  - Reserve a space for maintenance.  
Allow sufficient space for maintenance when designing the system.
  - Do not remove any nameplates or labels.  
This can lead to incorrect maintenance, or misreading of the operation manual, which could cause damage or malfunction to the product.  
It may also result in non-conformity to safety standards.

## ●Product handling

### \*Installation

- Do not drop, hit or apply excessive shock to the fieldbus system.  
Otherwise damage to the product can result, causing malfunction.
- Tighten to the specified tightening torque.  
If the tightening torque is exceeded the mounting screws may be broken.  
IP65/67 protection cannot be guaranteed if the screws are not tightened to the specified torque.
- Never mount a product in a location that will be used as a foothold.  
The product may be damaged if excessive force is applied by stepping or climbing onto it.

### \*Wiring

- Avoid repeatedly bending or stretching the cables, or placing heavy load on them.  
Repetitive bending stress or tensile stress can cause breakage of the cable.
- Wire correctly.  
Incorrect wiring can break the product.
- Do not perform wiring while the power is on.  
Otherwise damage to the fieldbus system and/or I/O device can result, causing malfunction.
- Do not route wires and cables together with power or high voltage cables.  
Otherwise the fieldbus system and/or I/O device can malfunction due to interference of noise and surge voltage from power and high voltage cables to the signal line.  
Route the wires (piping) of the fieldbus system and/or I/O device separately from power or high voltage cables.
- Confirm proper insulation of wiring.  
Poor insulation (interference from another circuit, poor insulation between terminals, etc.) can lead to excess voltage or current being applied to the product, causing damage.
- Take appropriate measures against noise, such as using a noise filter, when the fieldbus system is incorporated into equipment.  
Otherwise noise can cause malfunction.
- Separate the power line for output devices from the power line for control.  
Otherwise noise or induced surge voltage can cause malfunction.

### \*Environment

- Select the proper type of protection according to the environment of operation.  
IP65/67 protection is achieved when the following conditions are met.  
(1) The units are connected properly with fieldbus cable with M12 connector and power cable with M12 (M8) connector.  
(2) Suitable mounting of each unit and manifold valve.  
If using in an environment that is exposed to water splashes, please take measures such as using a cover.  
If the product is to be used in an environment containing oils or chemicals such as coolant or cleaning solvent, even for a short time, it may be adversely affected (damage, malfunction etc.).
- Do not use the product in an environment where corrosive gases or fluids could be splashed.  
Otherwise damage to the product and malfunction can result.
- Do not use in an area where surges are generated.  
If there is equipment which generates a large amount of surge (solenoid type lifter, high frequency induction furnace, motor, etc.) close to the fieldbus system, this may cause deterioration or breakage of the internal circuit of the fieldbus system. Avoid sources of surge generation and crossed lines.
- When a surge-generating load such as a relay or solenoid is driven directly, use an fieldbus system with a built-in surge absorbing element.  
Direct drive of a load generating surge voltage can damage the fieldbus system.
- The product is CE marked, but not immune to lightning strikes. Take measures against lightning strikes in the system.
- Prevent foreign matter such as remnant of wires from entering the fieldbus system to avoid failure and malfunction.



- Mount the product in a place that is not exposed to vibration or impact.  
Otherwise failure or malfunction can result.
- Do not use the product in an environment that is exposed to temperature cycle.  
Heat cycles other than ordinary changes in temperature can adversely affect the inside of the product.
- Do not expose the product to direct sunlight.  
If using in a location directly exposed to sunlight, shade the product from the sunlight.  
Otherwise failure or malfunction can result.
- Keep within the specified ambient temperature range.  
Otherwise malfunction can result.
- Do not operate close to a heat source, or in a location exposed to radiant heat.  
Otherwise malfunction can result.

\*Adjustment and Operation

- Perform settings suitable for the operating conditions.  
Incorrect setting can cause operation failure.
- Please refer to the PLC manufacturer's manual etc. for details of programming and addresses.  
For the PLC protocol and programming refer to the relevant manufacturer's documentation.

\*Maintenance

- Turn off the power supply, stop the supplied air, exhaust the residual pressure and verify the release of air before performing maintenance.  
There is a risk of unexpected malfunction.
- Perform regular maintenance and inspections.  
There is a risk of unexpected malfunction.
- After maintenance is complete, perform appropriate functional inspections.  
Stop operation if the equipment does not function properly.  
Otherwise safety is not assured due to an unexpected malfunction or incorrect operation.
- Do not use solvents such as benzene, thinner etc. to clean the each unit.  
They could damage the surface of the body and erase the markings on the body.  
Use a soft cloth to remove stains.  
For heavy stains, use a cloth soaked with diluted neutral detergent and fully squeezed, then wipe up the stains again with a dry cloth.

# Product Overview

## System construction

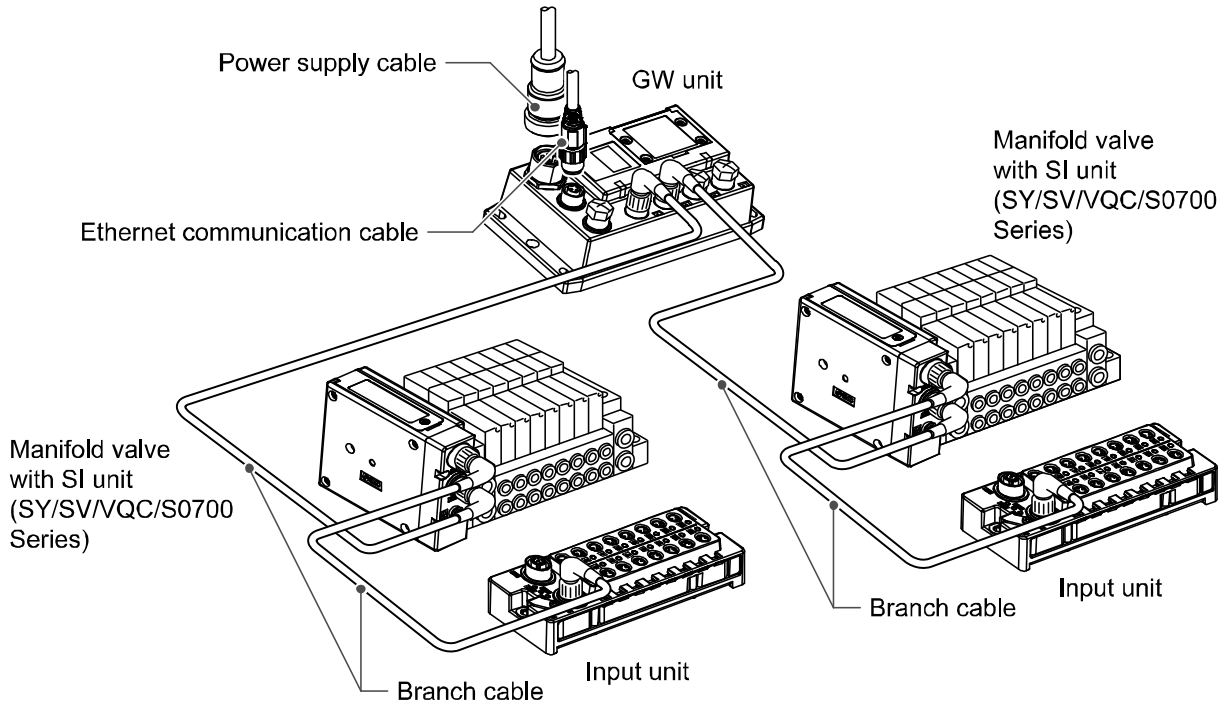

The EX500 range of units can be connected to open fieldbus (EtherNet/IP™) to realize the reduction of input or output device wiring and the distributed control system. One branch of manifold valves/input unit can be connected to 32 outputs/32 inputs. Up to 4 branches can be connected (total 128 outputs/128 inputs).

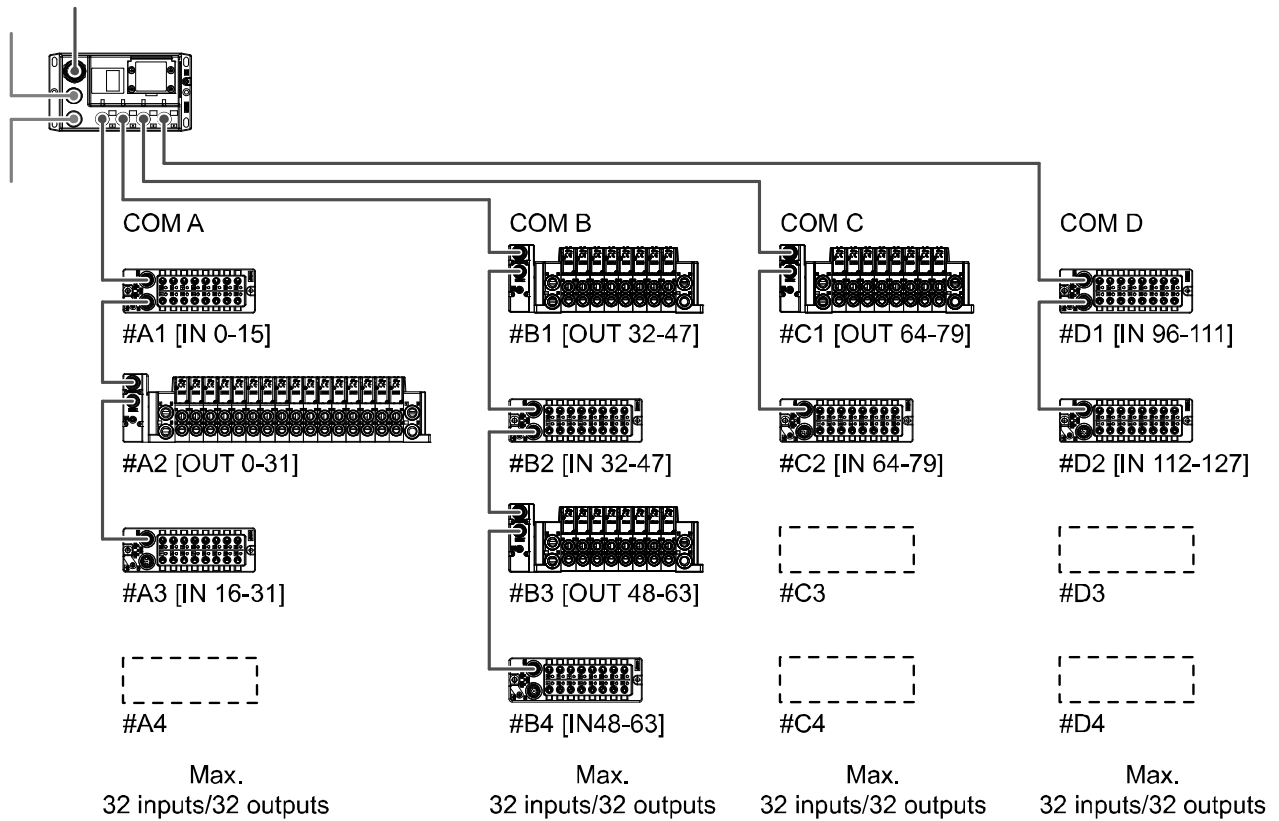

# EX500 GW unit

## Model Indication and How to Order

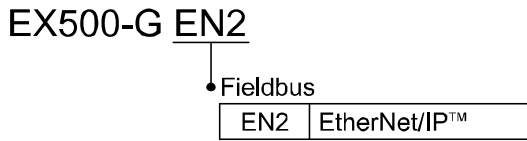

## Summary of Product parts

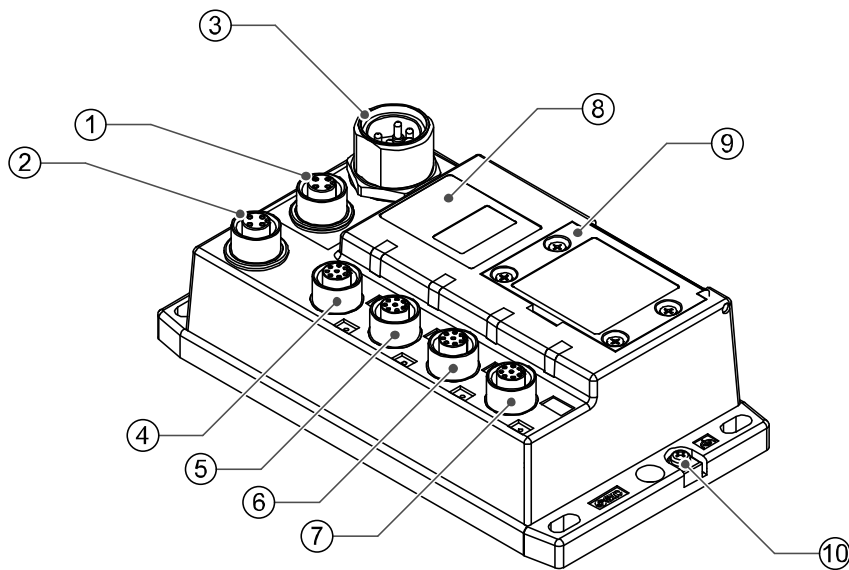

No.	Name	Application
1	Communication connector (Port1/IN)	Connect to EtherNet/IP™ line. *1
2	Communication connector (Port2/OUT)	
3	Power supply connector	Connector to supply power to the output devices such as solenoid valves and input and control equipment such as sensors. *1
4	Branch port A(COM A)	Connect the SI unit (with manifold valves) or input unit using a branch cable. *1
5	Branch port B(COM B)	
6	Branch port C(COM C)	
7	Branch port D(COM D)	
8	Display window	Displays the status of the power supply and the communication with the PLC. *2
9	Switch cover	Sets the address, etc. with the switch inside. *2
10	Grounding terminal (FE)	Used for functional grounding. (It is recommended to ground with resistance of 100 ohms or less)

### Accessories

Seal cap: 5 pcs. (for M12 connector socket)	Used for unused communication connector and branch ports.
--	---

\*1: Refer to page 12 for wiring.

\*2: Refer to page 17 for display and setting.

## Mounting and Installation

### ■ Installation

#### ● Direct mounting

Install the product using 4 M5 screws x 15 mm or longer with a head  $\varnothing 5.2$  minimum.

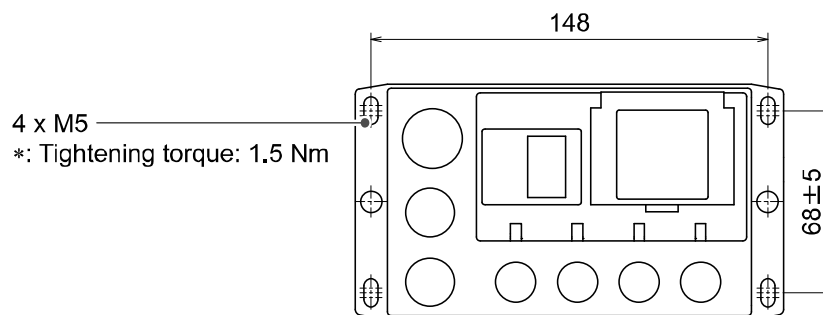

## ■Wiring

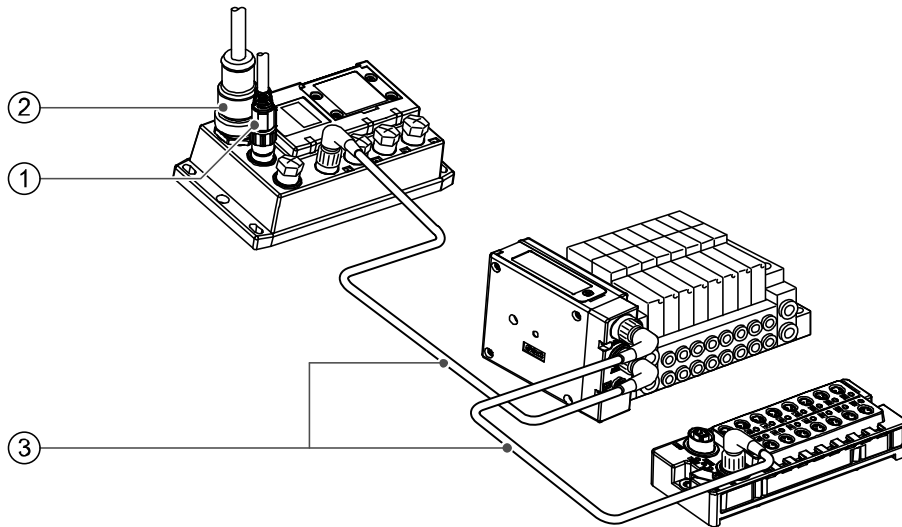

Described as follows:-

①Communication wiring: Connection with EtherNet/IP™



②Power supply wiring: Connection of the power supply for the solenoid valve and the power supply for input and control.



③Branch wiring: Connection from GW unit to SI unit or input unit.

### 1. Wiring for communication

Connect the Ethernet communication cable to the communication connector.

#### Communication connector pin layout (Port1/Port2)

M12, 4 pin, socket, D code.

No.	Description	
1	TX+	1
2	RX+	2
3	TX-	3
4	RX-	4

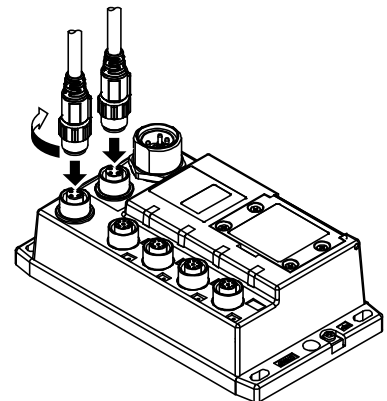

## 2. Power supply wiring

Connect a power supply cable to the power supply connector on the GW unit.  
Refer to page 6 for the selection of the power supply.

### Connector pin layout

7/8 inch, 4 pin, plug

No.	Description
1	24 VDC (For solenoid valves)
2	24 VDC (For input and control)
3	0 V (For input and control)
4	0 V (For solenoid valves)

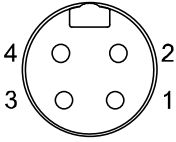
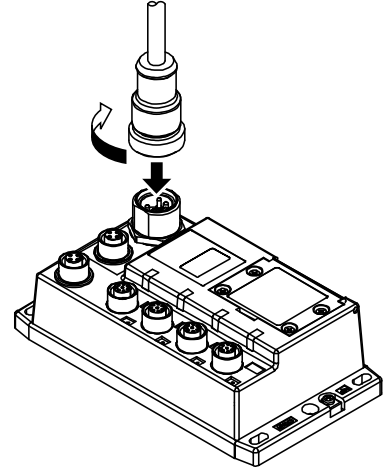
### Power supply

Either single or dual power supply can be used. Separate wiring for the solenoid valves and input / control is necessary.

#### A. With separate power supplies

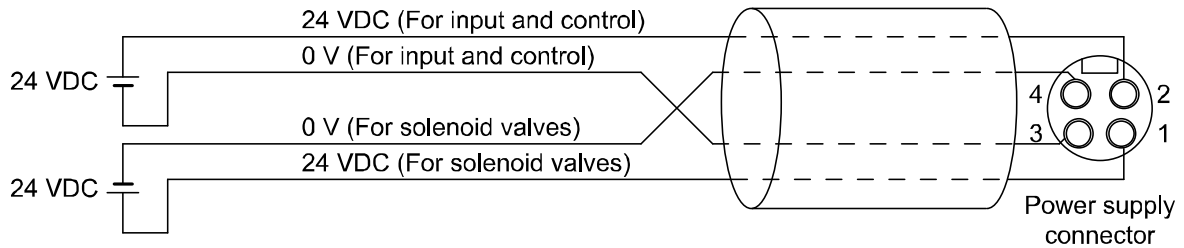

#### B. With one power supply

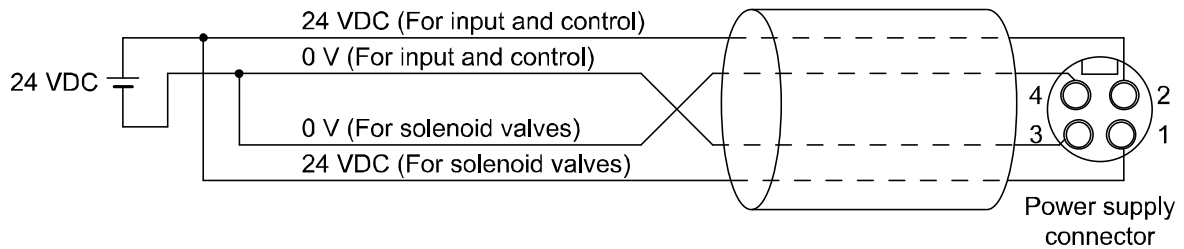

○Ground connection

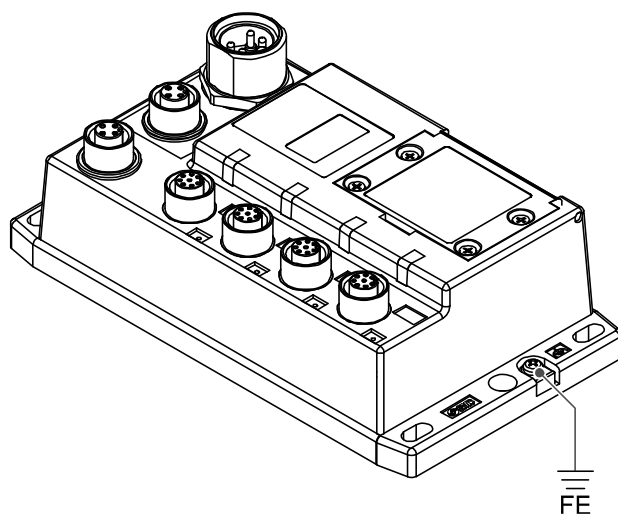

**Note**

Connect the FE terminal to ground.

### 3. Branch wiring

Connect the valve manifold with SI unit or an input unit to a branch port (COM A to D) using a branch cable (cable with M12 connector).

One branch port can be connected with up to 32 inputs and 32 outputs (Max. 4 units).

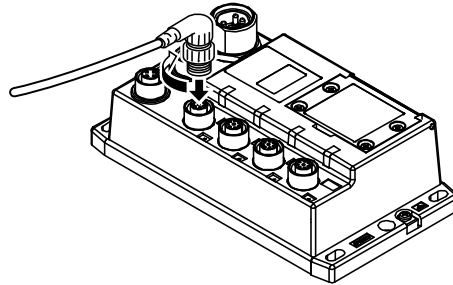
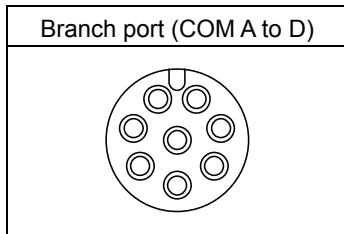

#### Note

Be sure to fit a seal cap on any unused connectors of the GW unit.  
IP65 is maintained by using the seal cap.  
(Tightening torque: 0.1 Nm)

#### [Connection example]

##### Connecting a GW unit to a valve manifold with SI unit and to an input unit

2 pcs. of the connector for wiring the branch cable are prepared for each SI unit and Input unit.

The branch cable from the GW unit is connected to the branch connector (IN).

The cable to the next SI unit or input unit is connected to the branch connector (OUT).

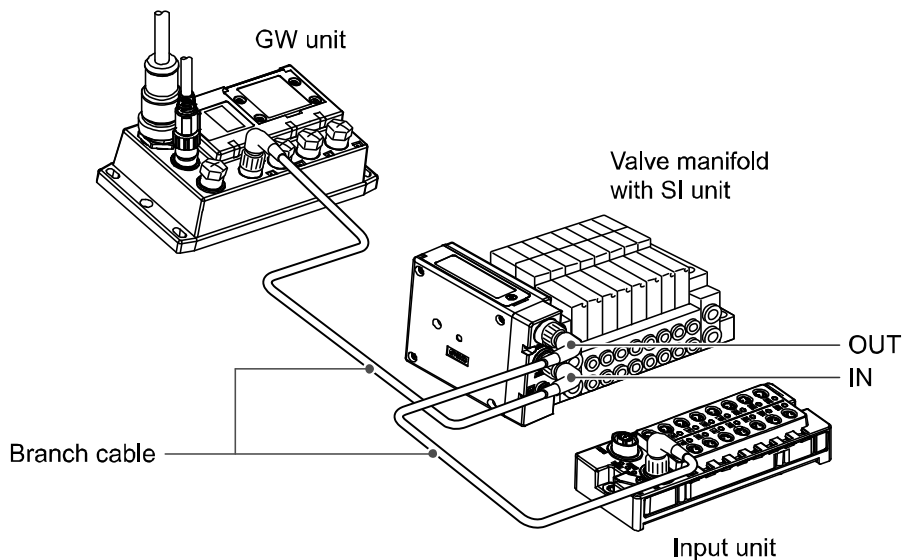



● Internal circuit

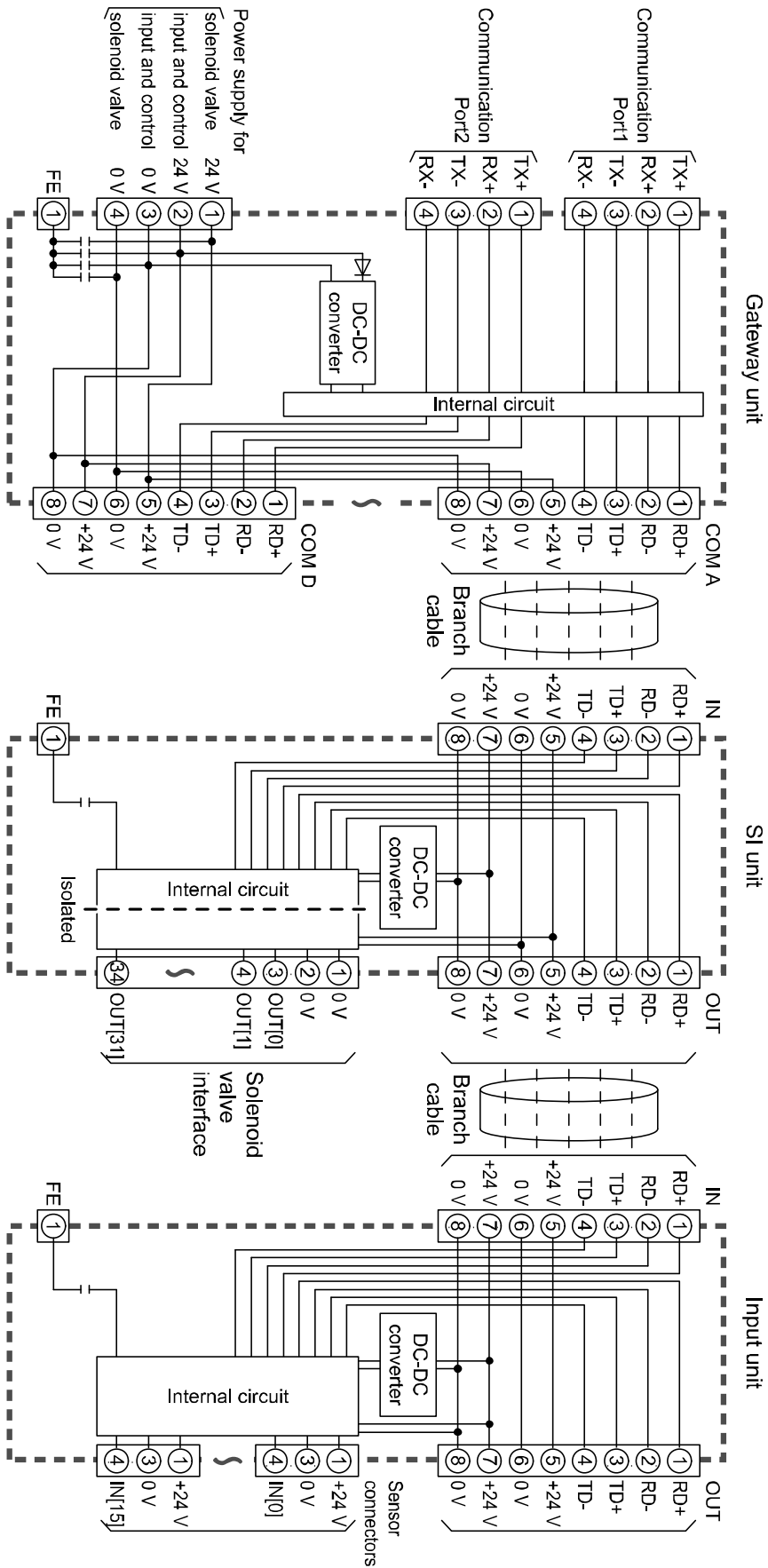

# LED Display

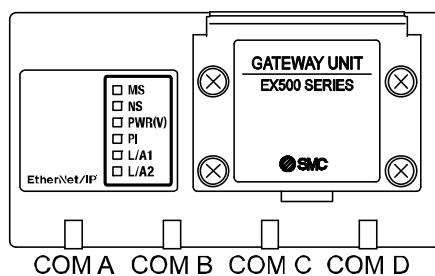

Display	Meaning	
MS	<input type="checkbox"/> LED is OFF	The power supply for input and control is OFF
	<input type="checkbox"/> Green LED is ON	Normal operation
	<input type="checkbox"/> Green LED is flashing	Parameter setting error
	<input type="checkbox"/> Red LED is flashing	Diagnostics error
	<input type="checkbox"/> Red LED is ON	Unrecoverable error
NS	<input type="checkbox"/> LED is OFF	IP address not set
	<input type="checkbox"/> Green LED is ON	EtherNet/IP™ communication established
	<input type="checkbox"/> Green LED is flashing	EtherNet/IP™ communication not established
	<input type="checkbox"/> Red LED is flashing	EtherNet/IP™ communications time out
	<input type="checkbox"/> Red LED is ON	IP address has been duplicated
PWR(V)	<input type="checkbox"/> LED is OFF	Power supply for Solenoid valve is OFF
	<input type="checkbox"/> Green LED is ON	Power supply for Solenoid valve is ON
PI	<input type="checkbox"/> LED is OFF	Forced output mode is disabled (Operating normally)
	<input type="checkbox"/> Orange LED is flashing	Ethernet UCMP Echo request (Ping command) received.
	<input type="checkbox"/> Orange LED is ON	Forced output mode is ON
L/A1	<input type="checkbox"/> LED is OFF	No Link, No Activity (Port1)
	<input type="checkbox"/> Green LED is ON	Link, No Activity (Port1, 100 Mbps)
	<input type="checkbox"/> Green LED is flashing	Link, Activity (Port1, 100 Mbps)
	<input type="checkbox"/> Orange LED is ON	Link, No Activity (Port1, 10 Mbps)
	<input type="checkbox"/> Orange LED is flashing	Link, Activity (Port1, 10 Mbps)
L/A2	<input type="checkbox"/> LED is OFF	No Link, No Activity (Port2)
	<input type="checkbox"/> Green LED is ON	Link, No Activity (Port2, 100 Mbps)
	<input type="checkbox"/> Green LED is flashing	Link, Activity (Port2, 100 Mbps)
	<input type="checkbox"/> Orange LED is ON	Link, No Activity (Port2, 10 Mbps)
	<input type="checkbox"/> Orange LED is flashing	Link, Activity (Port2, 10 Mbps)
COM A	<input type="checkbox"/> LED is OFF	Not connected
	<input type="checkbox"/> Green LED is ON	Normal operation
	<input type="checkbox"/> Green LED is flashing	Diagnostics error
COM B	<input type="checkbox"/> LED is OFF	Not connected
	<input type="checkbox"/> Green LED is ON	Normal operation
	<input type="checkbox"/> Green LED is flashing	Diagnostics error
COM C	<input type="checkbox"/> LED is OFF	Not connected
	<input type="checkbox"/> Green LED is ON	Normal operation
	<input type="checkbox"/> Green LED is flashing	Diagnostics error
COM D	<input type="checkbox"/> LED is OFF	Not connected
	<input type="checkbox"/> Green LED is ON	Normal operation
	<input type="checkbox"/> Green LED is flashing	Diagnostics error

## •Switch setting

Open the switch cover, and set the switches with a small flat blade screwdriver.

### Note

1. The power supply should be off while setting the switches.
2. The default setting is OFF or 0.
3. Whenever the switch cover has been opened, close the switch cover and tighten the screw to the specified torque.  
(Tightening torque: 0.6 Nm)

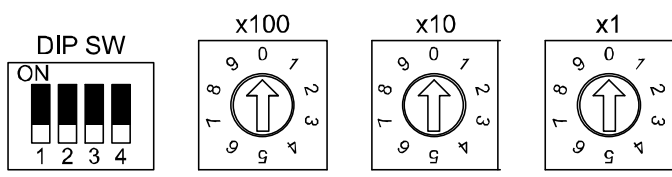

### IP address

Setting			Meaning
x100	x10	x1	
0	0	0	Remote control (DHCP) *1
0	0	1	Manual setting of IP address: 192.168.Y.X (X: 1-254) *2
0	0	2	
:	:	:	
2	5	4	DHCP mode *3
2	5	5	
2	5	6	Reserved
:	:	:	
9	9	9	

The default setting is 0.

### DIP switch

No.	Meaning
1	Reserved (Fixed to OFF)
2	HOLD/CLEAR setting ON: If EtherNet/IP™ communication error occurs, the output will be retained. OFF: Set the output condition during EtherNet/IP™ communication error via network. Cleared when this is not set.
3	Mode setting ON: Gateway distribution system (64 point) OFF: Gateway distribution system 2 (128 point)
4	Manual setting of IP address: 192.168.Y.X (Y: OFF_0, ON_1)

The default setting is OFF.

\*: Configuration

Please refer to the SMC website (URL <http://www.smcworld.com>) for applicable EDS file for the configuration of the network.

**\*1: Remoto control**

The mode to respond to the commands below of BOOTP/DHCP Server provided by Rockwell Automation.

Enable DHCP

Information including IP address can be obtained from BOOTP/DHCP Server. If the power is supplied again in this state, EX500 tries to obtain the information including IP address again.

Disable BOOTP/DHCP

Information including IP address is not obtained from BOOTP/DHCP Server. Previous setting can be held if power is supplied under this condition.

**\*2: Manual setting of IP address**

IP address is set within the range of 192.168.0.1 to 192.168.0.254, 192.168.1.1 to 192.168.1.254.

**\*3: DHCP mode**

Obtain IP address from DHCP Server. Obtained IP address is lost when power supply is cut.

**Default setting**

"Enable DHCP" at "Remote control".

\*4: See page 59.

**Note**

Remote Control mode

If IP address EX500 held is unknown, restart GW unit in DHCP mode temporarily and return to Remote control mode. Though the previous IP address is lost when GW unit is in DHCP mode, new IP address can be obtained from BOOTP/DHCP server.

# Setting of EtherNet/IP™ using RSLogix5000™

Method to connect a GW unit to the Rockwell Automation EtherNet/IP™ module (master) is shown below. Refer to the Operation Manual of the RSLogix5000™ for the detailed operation.

\*: This figure shows the display of Rockwell Automation software, RSLogix5000™.

- Select [EtherNet/IP™ module] in [I/O Configuration] folder, then select [New Module].

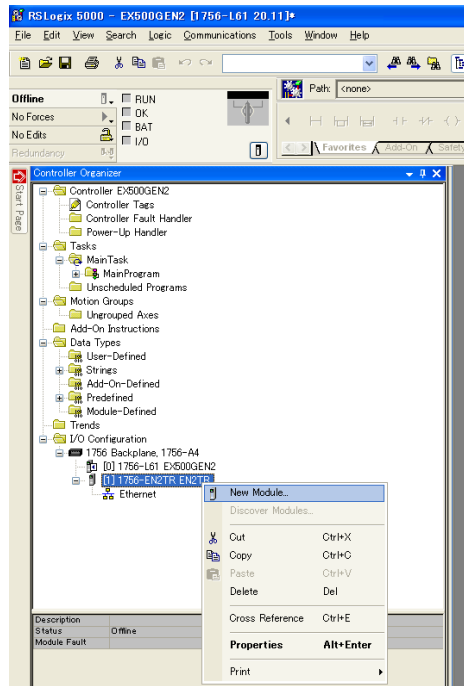

The [Select Module] screen is displayed. Select [ETHERNET-MODULE Generic Ethernet Module], then select [Create].

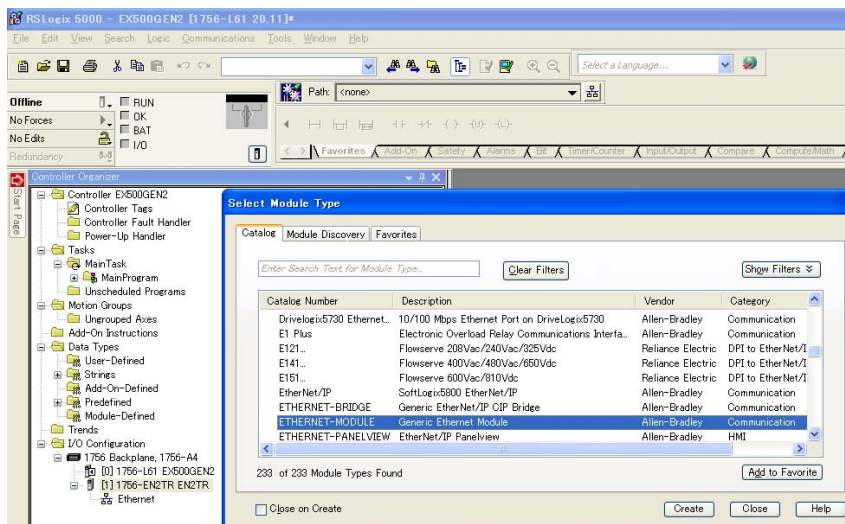

- The Module Properties screen is displayed. Perform each setting.
  - (1) Name: Enter the required unit name.
  - (2) Comm Format: Select the data format of Connection Parameters.
  - (3) IP Address: Enter the IP address setting for the GW unit.
  - (4) Assembly Instance: Perform setting as shown below.

Item	Decimal	
Common Format	"Data-INT"	"Data-SINT"
Input	100	100
Output	150	150
Configuration	130	130

- (5) Size: Perform setting as shown below.

Item	Decimal	
Common Format	"Data-INT"	"Data-SINT"
Input	10 (words)	20 (bytes)
Output	10 (words)	20 (bytes)
Configuration	0 or 34 (words)	0 or 68 (bytes)

\*: Set 0 for Configuration Size when configuration data setting is not changed from the default value. Configuration data setting will be explained later. Configuration data setting can be changed by setting 34 (words) or 68 (bytes). Refer to page 28 for the configuration data map.

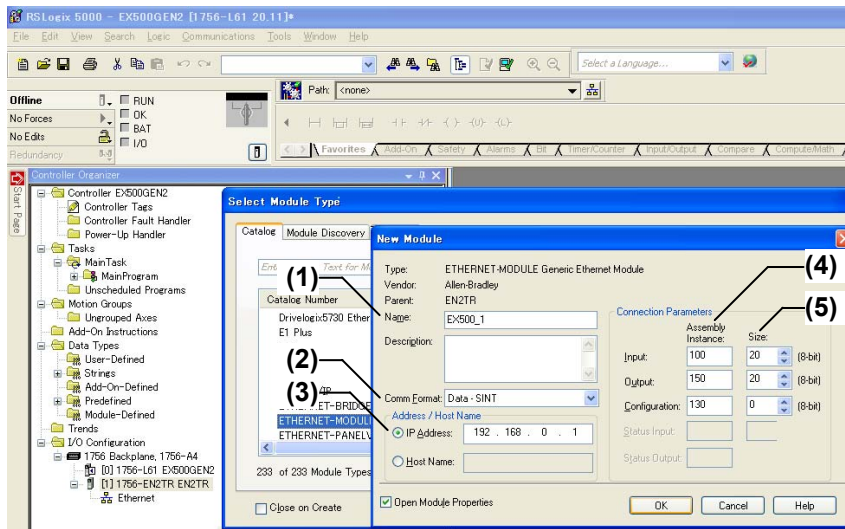

## I/O memory map

I/O data

Connection example

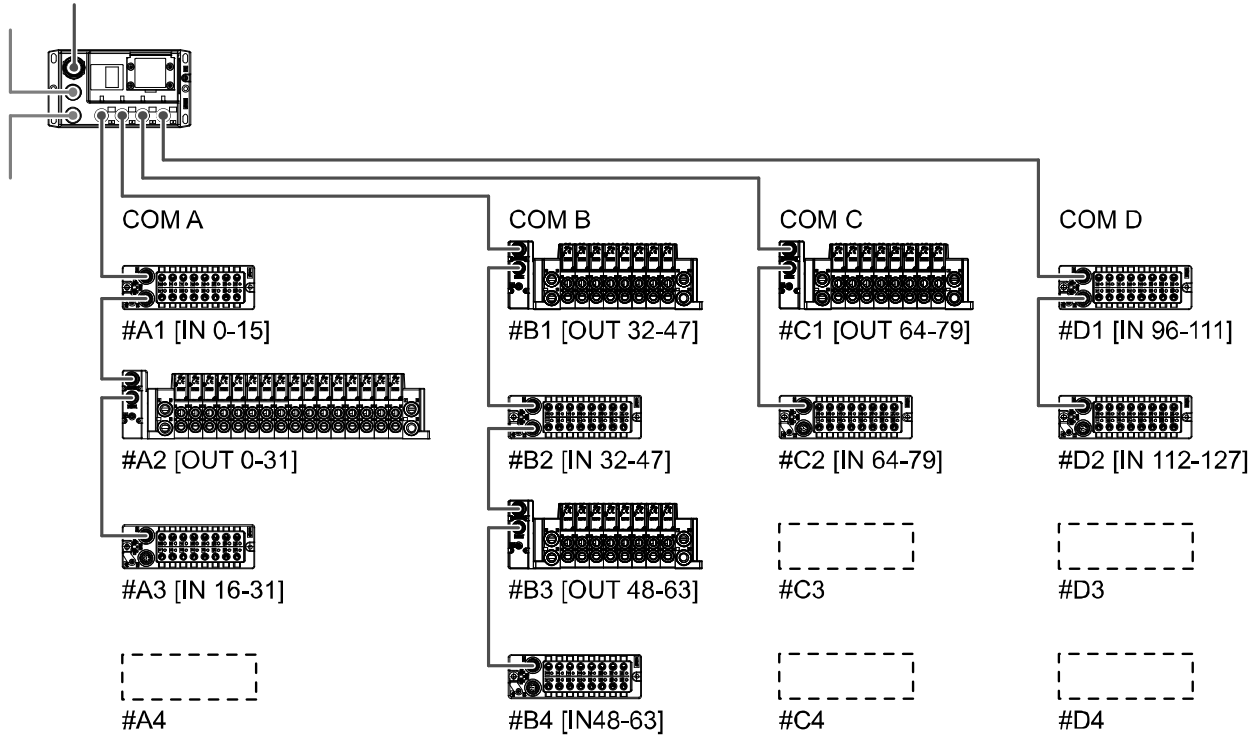

## Input data

Offset (INT)	Input data															Meaning		
	MSB							LSB										
	15	14	13	12	11	10	9	8	7	6	5	4	3	2			1	0
0	IN15	IN14	IN13	IN12	IN11	IN10	IN9	IN8	IN7	IN6	IN5	IN4	IN3	IN2	IN1	IN0	COM A	Input data
1	IN31	IN30	IN29	IN28	IN27	IN26	IN25	IN24	IN23	IN22	IN21	IN20	IN19	IN18	IN17	IN16	COM B	
2	IN47	IN46	IN45	IN44	IN43	IN42	IN41	IN40	IN39	IN38	IN37	IN36	IN35	IN34	IN33	IN32	COM C	
3	IN63	IN62	IN61	IN60	IN59	IN58	IN57	IN56	IN55	IN54	IN53	IN52	IN51	IN50	IN49	IN48	COM D	
4	IN79	IN78	IN77	IN76	IN75	IN74	IN73	IN72	IN71	IN70	IN69	IN68	IN67	IN66	IN65	IN64		
5	IN95	IN94	IN93	IN92	IN91	IN90	IN89	IN88	IN87	IN86	IN85	IN84	IN83	IN82	IN81	IN80		
6	IN111	IN110	IN109	IN108	IN107	IN106	IN105	IN104	IN103	IN102	IN101	IN100	IN99	IN98	IN97	IN96		
7	IN127	IN126	IN125	IN124	IN123	IN122	IN121	IN120	IN119	IN118	IN117	IN116	IN115	IN114	IN113	IN112		
8	#D4	#D3	#D2	#D1	#C4	#C3	#C2	#C1	#B4	#B3	#B2	#B1	#A4	#A3	#A2	#A1	Slave condition	Diagnostic data
9	Error code											COM_D	COM_C	COM_B	COM_A	Port diagnosis/ Error code		

## Output data

Offset (INT)	Output data																Meaning		
	MSB								LSB										
	15								0										
0	OUT15	OUT14	OUT13	OUT12	OUT11	OUT10	OUT9	OUT8	OUT7	OUT6	OUT5	OUT4	OUT3	OUT2	OUT1	OUT0	COM A	Output data	
1	OUT31	OUT30	OUT29	OUT28	OUT27	OUT26	OUT25	OUT24	OUT23	OUT22	OUT21	OUT20	OUT19	OUT18	OUT17	OUT16			
2	OUT47	OUT46	OUT45	OUT44	OUT43	OUT42	OUT41	OUT40	OUT39	OUT38	OUT37	OUT36	OUT35	OUT34	OUT33	OUT32			COM B
3	OUT63	OUT62	OUT61	OUT60	OUT59	OUT58	OUT57	OUT56	OUT55	OUT54	OUT53	OUT52	OUT51	OUT50	OUT49	OUT48			
4	OUT79	OUT78	OUT77	OUT76	OUT75	OUT74	OUT73	OUT72	OUT71	OUT70	OUT69	OUT68	OUT67	OUT66	OUT65	OUT64	COM C		
5	OUT95	OUT94	OUT93	OUT92	OUT91	OUT90	OUT89	OUT88	OUT87	OUT86	OUT85	OUT84	OUT83	OUT82	OUT81	OUT80			
6	OUT111	OUT110	OUT109	OUT108	OUT107	OUT106	OUT105	OUT104	OUT103	OUT102	OUT101	OUT100	OUT99	OUT98	OUT97	OUT96	COM D		
7	OUT127	OUT126	OUT125	OUT124	OUT123	OUT122	OUT121	OUT120	OUT119	OUT118	OUT117	OUT116	OUT115	OUT114	OUT113	OUT112			
8	#D4	#D3	#D2	#D1	#C4	#C3	#C2	#C1	#B4	#B3	#B2	#B1	#A4	#A3	#A2	#A1	Slave connection diagnosis	Diagnostic setting	
9	-	-	-	-	-	-	-	-	-	-	-	-	COM_D	COM_C	COM_B	COM_A	32 point switch diagnosis		

-: Unused



○Diagnostic data

Diagnostic information

Offset (INT)	Input data																Meaning														
	MSB								LSB																						
	15								8									7								0					
8	#D4	#D3	#D2	#D1	#C4	#C3	#C2	#C1	#B4	#B3	#B2	#B1	#A4	#A3	#A2	#A1	Slave condition														
9	Error code												COM_D	COM_C	COM_B	COM_A	Port diagnosis/ Error code														

< Slave condition >

Value	Slave condition
0	Not connected
1	Connection port

< Port diagnosis >

Value	Status
0	OK
1	ERR

< Error code >

Message code showing the diagnostic error and position code showing error location are stored.  
All 0 when no error has occurred.

Message code				Position code (Order #1 - #4, Port A - D)							
				#4	#3	#2	#1	D	C	B	A
0	0	1	0	0	0	0	1	0	0	0	1
Message code 0x2				Product No.1				A port			

Ex.: Short-circuit or over current error with the first slave of COM A port.

Message code and corrective action for diagnostic error are shown below.

Message Code	Name of Diagnostic error	Meaning of Diagnostic Error
0x0	(No error)	There is no error.
0x1	Short-circuit or over current (lost connection)	Short circuit or over current of GW unit branch port input and control power supply.
0x2	Short-circuit or over current	Short circuit or over current of input unit sensor connector.
0x3	More than 32 input	More than 32 inputs are connected to 1 port.
0x4	More than 32 output	More than 32 outputs are connected to 1 port.
0x5	More than 4 slaves	More than 4 slaves are connected to 1 port.
0x6	Lost connection or configuration error	Slave specified by the diagnostic setting "Slave connection diagnostic" is not connected.
0x7	Dip switch is not set to "32out."	SI unit which is not 32 output is connected to the port specified by diagnostic setting < 32 point switch diagnostic >
0x8-0xF	Reserve	-

## Diagnostic setting

Offset (INT)	Output data																Meaning														
	MSB								LSB																						
	15								8									7								0					
8	#D4	#D3	#D2	#D1	#C4	#C3	#C2	#C1	#B4	#B3	#B2	#B1	#A4	#A3	#A2	#A1	Slave connection diagnostic														
9	-	-	-	-	-	-	-	-	-	-	-	-	COM_D	COM_C	COM_B	COM_A	32 point switch diagnostic														

-: Unused

### < Slave connection diagnostic >

Value	Setting
0	Disabled
1	Enabled

\*: See page 26.

### < 32 point switch diagnostic >

Value	Setting
0	Disabled
1	Enabled

\*: See page 27.

< Slave connection diagnostic >

Diagnostic function to detect the branch cable broken wire or incorrect configuration of the slave connection.

Diagnostic error can be generated when the slave is not connected by setting "1" (enabled) for the diagnostic bit of the slave connection.

Refer to the figure below for the usage.

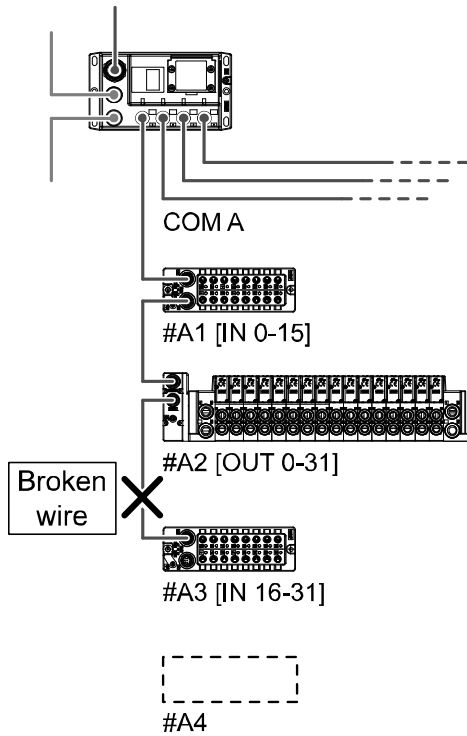

Offset (INT)	Output data																Meaning
	MSB								LSB								
	15								8								
8	#D4	#D3	#D2	#D1	#C4	#C3	#C2	#C1	#B4	#B3	#B2	#B1	#A4	#A3	#A2	#A1	Slave connection diagnosis
	0	0	0	0	0	0	0	0	0	0	0	0	0	1	1	1	

In the figure above, #A1 to #A3 are slaves for which the connection is diagnosed.

In this case, #A3 slave is not connected, and a diagnostic error is generated.

Here, the < Port diagnostic > of the input data is "1".

Offset (INT)	Input data																Meaning
	MSB								LSB								
	15								8								
8	#D4	#D3	#D2	#D1	#C4	#C3	#C2	#C1	#B4	#B3	#B2	#B1	#A4	#A3	#A2	#A1	Slave condition
	0	0	0	0	0	0	0	0	0	0	0	0	0	0	1	1	
9	Error code												COM_D	COM_C	COM_B	COM_A	Port diagnostic/ Error code
	0	1	1	0	0	1	0	0	0	0	0	0	1	0	0	0	

< 32 point switch diagnostic >

Detect the incorrect setting of the SI unit switch.

When a manifold with more than 17 valves is used, by setting "1" (enabled) to 32 point switch diagnostic bit, a diagnostic error can be generated when SI unit switch is set to 16 point output by mistake.

Refer to the figure below for the usage.

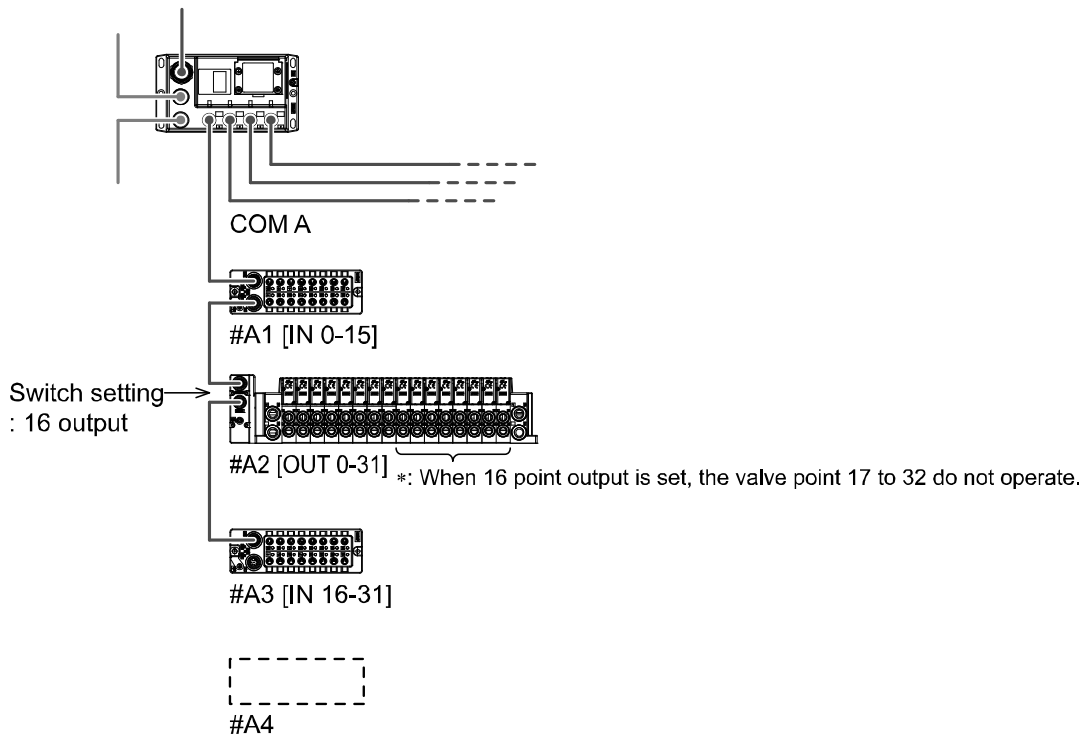

Offset (INT)	Output data																Meaning
	MSB								LSB								
	15								7								
9	Reserve												COM_D	COM_C	COM_B	COM_A	32 point switch diagnosis
	-	-	-	-	-	-	-	-	-	-	-	-	-	0	0	0	1

In the figure above, COM A is the subject of 32 point switch diagnostic.

In this case, diagnostic error is generated as the SI unit of 16 point output setting is connected.

Here, the < Port diagnostic > of the input data is "1".

Offset (INT)	Input data																Meaning
	MSB								LSB								
	15								7								
8	#D4	#D3	#D2	#D1	#C4	#C3	#C2	#C1	#B4	#B3	#B2	#B1	#A4	#A3	#A2	#A1	Slave condition
	0	0	0	0	0	0	0	0	0	0	0	0	0	1	1	1	
9	Error code												COM_D	COM_C	COM_B	COM_A	Port diagnostic/ Error code
	0	1	1	1	0	0	0	1	0	0	0	1	0	0	0	1	

●Configuration data map

Offset (INT)	Configuration data															
	MSB								LSB							
	15								7							
0	-	-	-	-	-	-	-	-	-	-	QC	Web forcing	COM_D diag	COM_C diag	COM_B diag	COM_A diag
1	FA_OUT7		FA_OUT6		FA_OUT5		FA_OUT4		FA_OUT3		FA_OUT2		FA_OUT1		FA_OUT0	
2	FA_OUT15		FA_OUT14		FA_OUT13		FA_OUT12		FA_OUT11		FA_OUT10		FA_OUT9		FA_OUT8	
3	FA_OUT23		FA_OUT22		FA_OUT21		FA_OUT20		FA_OUT19		FA_OUT18		FA_OUT17		FA_OUT16	
4	FA_OUT31		FA_OUT30		FA_OUT29		FA_OUT28		FA_OUT27		FA_OUT26		FA_OUT25		FA_OUT24	
5	FA_OUT39		FA_OUT38		FA_OUT37		FA_OUT36		FA_OUT35		FA_OUT34		FA_OUT33		FA_OUT32	
6	FA_OUT47		FA_OUT46		FA_OUT45		FA_OUT44		FA_OUT43		FA_OUT42		FA_OUT41		FA_OUT40	
7	FA_OUT55		FA_OUT54		FA_OUT53		FA_OUT52		FA_OUT51		FA_OUT50		FA_OUT49		FA_OUT48	
8	FA_OUT63		FA_OUT62		FA_OUT61		FA_OUT60		FA_OUT59		FA_OUT58		FA_OUT57		FA_OUT56	
9	FA_OUT71		FA_OUT70		FA_OUT69		FA_OUT68		FA_OUT67		FA_OUT66		FA_OUT65		FA_OUT64	
10	FA_OUT79		FA_OUT78		FA_OUT77		FA_OUT76		FA_OUT75		FA_OUT74		FA_OUT73		FA_OUT72	
11	FA_OUT87		FA_OUT86		FA_OUT85		FA_OUT84		FA_OUT83		FA_OUT82		FA_OUT81		FA_OUT80	
12	FA_OUT95		FA_OUT94		FA_OUT93		FA_OUT92		FA_OUT91		FA_OUT90		FA_OUT89		FA_OUT88	
13	FA_OUT103		FA_OUT102		FA_OUT101		FA_OUT100		FA_OUT99		FA_OUT98		FA_OUT97		FA_OUT96	
14	FA_OUT111		FA_OUT110		FA_OUT109		FA_OUT108		FA_OUT107		FA_OUT106		FA_OUT105		FA_OUT104	
15	FA_OUT119		FA_OUT118		FA_OUT117		FA_OUT116		FA_OUT115		FA_OUT114		FA_OUT113		FA_OUT112	
16	FA_OUT127		FA_OUT126		FA_OUT125		FA_OUT124		FA_OUT123		FA_OUT122		FA_OUT121		FA_OUT120	
17 - - - 33	Reserve															

-: Unused

< Configuration data >

- COM\_A to COM\_D diag: Select the output operation during a diagnostic error for each port.

0: Continue (Default)  
1: Stop

- Web forcing: Limit the forced output function of Web server function.

0: Forced output is disabled while EtherNet/IP™ communication is established (default status).  
1: Forced output is available while EtherNet/IP™ communication is established.

- QC: QuickConnect™ function can be selected. \*1

0: Invalid (Default)  
1: Enabled

\*: When enabled, Auto-Negotiation (A-N) is disabled. The communication speed is 100 Mbps. Communication is fixed to full duplex. Make sure the value is set to "0" when the QuickConnect™ function is not used.

- FA\_OUT0 to FA\_OUT127: Hold or Clear of output can be set during EtherNet/IP™ communication error.

00: Clear (Default)  
01: Forced output ON  
1X: Hold

\*: Make sure the switch No. 2 is OFF when this configuration data is used. See page 18.

\*1: EtherNet/IP™ QuickConnect™ function

This GW unit can be used as an EtherNet/IP™ compliant node for networks with the QuickConnect™ function.

To enable the QuickConnect™ function, it is necessary to perform the settings 1 to 2 to the GW unit as shown below.

After satisfying the conditions 1 to 2, setting of the QuickConnect™ function compliant EtherNet/IP™ module (master), according to the specified procedure, must be performed. Refer to the manual for the EtherNet/IP™ module (master) for the specified operation procedure.

1. IP address not set

The IP address is set either by manual setting using switches, or by Remote control (with the IP address X "000").

When setting the IP address by remote control, first obtain the IP address through the BOOTP/DHCP Server, then select the Disable DHCP button to hold the IP address.

2. Communication setting

GW communication setting is changed by one of the followings methods.

(1) Configuration data

Set "1" to configuration data "QC" referring to the configuration data map on page 28.

Make sure the value is set to "0" when the QuickConnect™ function is not used.

(2) Changed by CIP™ Object.

Change the EtherNet Link Object to the values shown below.

Setting of communication port 1

Class ID	Inst ID	Attr ID	Access Rule	Name	Semantics of Values	Quick Connect
F6h [EtherNet Link Object]	1 h	6 h	Get/Set	Interface Control	01000000 = A-N Enable(Default)	Not use
					02006400 = A-N Disable, Force 100 Mbps Full duplex	Use

Setting of communication port 2

Class ID	Inst ID	Attr ID	Access Rule	Name	Semantics of Values	Quick Connect
F6h [EtherNet Link Object]	2 h	6 h	Get/Set	Interface Control	01000000 = A-N Enable(Default)	Not use
					02006400 = A-N Disable, Force 100 Mbps Full duplex	Use

\*: Make sure the value is set to "01000000" when the QuickConnect™ function is not used.

Change the TCP/IP Object to the values shown below.

Class ID	Inst ID	Attr ID	Access Rule	Name	Semantics of Values	Quick Connect
F5h [TCP/IP Object]	1 h	Ch	Get/Set	EtherNet/IP QuickConnect	0 = Disable(Default)	Not use
					1 = Enable	Use

\*: Make sure the value is set to "0" when the QuickConnect™ function is not used.

## ■ Web server function

The GW unit has a Web server function which allows checking the information of the slave configuration from a PC Web browser during maintenance, or checking of I/O monitor or forced output of ON/OFF of the valve.

### ● Connection of GW unit and PC

Connect GW unit and PC to the same Ethernet network, then start the Web browser on the PC.

The GW unit can be connected to the Web server by inputting GW unit IP address to the Web browser address bar.

#### **NOTE**

Set the same significant 3 octets of PC IP address as GW unit IP address.

Set the PC subnet mask to "255.255.255.0".

Ex. 1 GW unit: 192.168.0.100	PC: 192.168.0.1	OK: Correct IP address setting
Ex. 2 GW unit: 192.168.0.100	PC: 192.168.3.1	NG: Incorrect IP address setting

●Web server contents

Web browser screen when the Web server is connected is shown below.

< Slave information tab (Home screen) >

Slave configuration corresponding to the condition of each COM port is displayed.

① IP Address : 192.168.0.1      EX500-GEN2  
GW Unit for EtherNet/IP      ② Force output : Inactive

③ Module status : Operating Normally      ④ Network status : Established

⑤ Slave Information      I/O Status      Properties

⑥ #1      #2      #3      #4      Message:

COM A	16 Input	32 Output	16 Input	
COM B	16 Input	16 Output	16 Input	16 Output
COM C	16 Output	16 Input		
COM D	16 Input	16 Input		

■ :Slave connection error enabled and no faults.  
■ :Slave connection error disabled and no faults.  
■ :Diagnostics error.

Copyright © SMC Corporation. All Rights Reserved

16 Input: Input unit is connected.

16 Output: SI unit (16 output) is connected.

32 Output: SI unit (32 output) is connected.

Blank: Slave is not connected.

No.	Item	Meaning
1	IP Address	IP address of GW unit connected to Web server
2	Force output	Force output mode enable/disable. Active: Force output mode enabled Inactive: Force output mode disabled
3	Module status	GW unit operating condition. Operating Normally: Normal operation Diagnostics Error: Diagnostic error detected
4	Network status	Displays the communication status of the GW unit EtherNet/IP™. Established: EtherNet/IP™ communication is established Not established: EtherNet/IP™ communication is not established Timeout: EtherNet/IP™ communications time out
5	Menu tab	Menu is changed by selecting the tab.
6	Slave configuration	Configuration of SI unit and input unit connected to each branch port.



●Diagnostic error

Example below shows Slave information when a diagnostic error is generated.

Diagnostic error name is displayed in Message space. \*

IP Address : 192.168.0.1    EX500-GEN2 GW Unit for EtherNet/IP    Force output : Inactive

Module status : **Diagnostics Error**    Network status : Established

Slave Information    I/O Status    Properties

	#1	#2	#3	#4	Message:
COM A	16 Input	32 Output	16 Input	No Module	... Lost connection or configuration error
COM B	16 Input	16 Output	16 Input	16 Output	... More than 4 slaves
COM C	16 Output	16 Input			... Short-circuit or over current
COM D	16 Input	16 Input	16 Input		... More than 32 input

■ :Slave connection error enabled and no faults.  
■ :Slave connection error disabled and no faults.  
■ :Diagnostics error.

Copyright © SMC Corporation. All Rights Reserved.

Diagnostic Error name and meaning

Problems	Error meaning
Short-circuit or over current (lost connection)	Short circuit or over current of GW unit branch port input and control power supply.
Short-circuit or over current	Short circuit or over current of input unit sensor connector.
More than 32 input	More than 32 inputs is connected to 1 port.
More than 32 output	More than 32 outputs is connected to 1 port.
More than 4 slaves	More than 4 slaves are connected to 1 port.
Lost connection or configuration error	Slave specified by the diagnostic setting "Slave connection diagnostic" is not connected.
Dip switch is not set to "32out."	SI unit which is not 32 output is connected to the port specified by diagnostic setting < 32 point switch diagnostic >.

\*: One representative error is displayed when multiple errors are generated simultaneously in the same port. Following message will be displayed after the errors are solved.

< I/O Status tab >

Current GW unit I/O memory map is displayed.

[Example] Refer to page 22 for details.

IP Address : 192.168.0.1      EX500-GEN2      Force output : Inactive  
 Module status : **Operating Normally**      GW Unit for EtherNet/IP      Network status : **Established**



Slave Information    I/O Status    Properties

Offset (INT)	INPUT DATA																Hex	Description
	Bit																	
0	15	14	13	12	11	10	9	8	7	6	5	4	3	2	1	0	#5555	Com A - Slave#1
1	1	0	1	0	1	0	1	0	1	0	1	0	1	0	1	0	#AAAA	Com A - Slave#3
2	0	0	0	0	0	0	0	0	0	0	0	0	0	0	0	0	#0000	Com B - Slave#1
3	0	1	0	1	0	1	0	1	0	1	0	1	0	1	0	1	#5555	Com B - Slave#3
4	0	1	0	1	0	1	0	1	0	1	0	1	0	1	0	1	#5555	Com C - Slave#2
5	0	0	0	0	0	0	0	0	0	0	0	0	0	0	0	0	#0000	Com C - Not allocated
6	0	1	0	1	0	1	0	1	0	1	0	1	0	1	0	1	#5555	Com D - Slave#1
7	0	0	0	0	0	0	0	0	0	0	0	0	0	0	0	0	#0000	Com D - Slave#2
8	#D4	#D3	#D2	#D1	#C4	#C3	#C2	#C1	#B4	#B3	#B2	#B1	#A4	#A3	#A2	#A1	#33F7	Slave connected status
	0	0	1	1	0	1	1	1	1	1	1	1	0	1	1	1		
9	Error code												COM_D	COM_C	COM_B	COM_A	#0000	Port diagnostics
	0	0	0	0	0	0	0	0	0	0	0	0	0	0	0	0		

Change Password      Execute      Reset      Force output

Offset (INT)	OUTPUT DATA																Hex	Description
	Bit																	
0	15	14	13	12	11	10	9	8	7	6	5	4	3	2	1	0	#AAAA	Com A - Slave#2
1	1	0	1	0	1	0	1	0	1	0	1	0	1	0	1	0	#AAAA	Com A - Slave#2
2	1	0	1	0	1	0	1	0	1	0	1	0	1	0	1	0	#AAAA	Com B - Slave#2
3	1	0	1	0	1	0	1	0	1	0	1	0	1	0	1	0	#AAAA	Com B - Slave#4
4	0	0	0	0	0	0	0	0	0	0	0	0	0	0	0	0	#0000	Com C - Slave#1
5	0	0	0	0	0	0	0	0	0	0	0	0	0	0	0	0	#0000	Com C - Not allocated
6	0	0	0	0	0	0	0	0	0	0	0	0	0	0	0	0	#0000	Com D - Not allocated
7	0	0	0	0	0	0	0	0	0	0	0	0	0	0	0	0	#0000	Com D - Not allocated
8	#D4	#D3	#D2	#D1	#C4	#C3	#C2	#C1	#B4	#B3	#B2	#B1	#A4	#A3	#A2	#A1	#00F7	Enable slave connection errors
	0	0	0	0	0	0	0	0	1	1	1	1	0	1	1	1		
9	Reserved												COM_D	COM_C	COM_B	COM_A	#0000	32out switch diagnostic setting
	-	-	-	-	-	-	-	-	-	-	-	-	-	0	0	0		

No.	Item	Meaning
1	Force output	Select for force output mode.
2	Change password	Select for changing the password to enable changing to force output mode.

•Forced output mode

Procedure to change to forced output mode and the method of forced output.

Warning and password input screen will appear by selecting the Force output button.

Force output space becomes active when the password entered is successful. The mode will be changed to force output mode.

Initial password is "SMCEX500".

IP Address : 192.168.0.1      EX500-GEN2      Force output : Inactive  
 GW Unit for EtherNet/IP

Module status : Operating Normally      Network status : Not Established

Slave Information    I/O Status    Properties

Offset (INT)	INPUT DATA																Hex	Description	
	15	14	13	12	11	10	9	8	7	6	5	4	3	2	1	0			
0	0	1	0	1	0												1	#5555	Com A - Slave#1
1	1	0	1	0	1												0	#AAAA	Com A - Slave#3
2	0	0	0	0	0												0	#0000	Com B - Slave#1
3	0	1	0	1	0												1	#5555	Com B - Slave#3
4	0	1	0	1	0												1	#5555	Com C - Slave#2
5	0	0	0	0	0												0	#0000	Com C - Not allocated
6	0	1	0	1	0												1	#5555	Com D - Slave#1
7	0	0	0	0	0												0	#0000	Com D - Slave#2
8	#D4	#D3	#D2	#D1	#C4												#A1	#33F7	Slave connected status
9	0	0	0	0	0												COM_A	#0000	Port diagnostics

**Warning**

\*Forced outputs are maintained until they are reset using the "Reset" button or function, cleared by clicking the "Force Output Exit" button or power to the EX500 is turned off.(Forces will remain active if the web application is shut down)

\*If output forcing is enabled through the web browser the PLC will not be able to communicate with the EX500.

Enabled force outputs?

Password:

Offset (INT)	15	14	13	12	11	10	9	8	7	6	5	4	3	2	1	0	Hex	Description				
0	0	0	0	0	0												0	#0000	Com A - Slave#2			
1	0	0	0	0	0												0	#0000	Com A - Slave#2			
2	0	0	0	0	0												0	#0000	Com B - Slave#2			
3	0	0	0	0	0												0	#0000	Com B - Slave#4			
4	0	0	0	0	0												0	#0000	Com C - Slave#1			
5	0	0	0	0	0												0	#0000	Com C - Not allocated			
6	0	0	0	0	0												0	#0000	Com D - Not allocated			
7	0	0	0	0	0												0	#0000	Com D - Not allocated			
8	#D4	#D3	#D2	#D1	#C4	#C3	#C2	#C1	#B4	#B3	#B2	#B1	#A4	#A3	#A2	#A1		#0000	Enable slave connection errors			
9	-	-	-	-	-	-	-	-	-	-	-	-	-	-	-	-	COM_D	COM_C	COM_B	COM_A	#0000	32out switch diagnostic setting

**< CAUTION >**

- Forced output is valid until selecting Reset or Force output exit.  
 Forced output is valid even if the network is shut down during forced output mode.  
 (Forced output is released when GW unit power supply is off.)
- While EtherNet/IP™ communication is established, the message below is shown and it is not possible to change to forced output mode. Set 1 for the configuration data Web forcing when forced output is used while communication is established.

Output forcing is only allowed when PLC is not connected.

OUTPUT DATA becomes editable in forced output mode.  
 Edited OUTPUT DATA is displayed in red.

After OUTPUT DATA is edited, the output data will be reflected by selecting "Execute".  
 Reflected OUTPUT DATA is displayed in yellow.

IP Address : 192.168.0.1      EX500-GEN2      Force output : **Active**  
 Module status : **Operating Normally**      GW Unit for EtherNet/IP      Network status : **Not Established**      

Slave Information    I/O Status    Properties

Offset (INT)	INPUT DATA																Hex	Description
	Bit																	
0	15	14	13	12	11	10	9	8	7	6	5	4	3	2	1	0	#5555	Com A - Slave#1
1	1	0	1	0	1	0	1	0	1	0	1	0	1	0	1	0	#AAAA	Com A - Slave#3
2	0	0	0	0	0	0	0	0	0	0	0	0	0	0	0	0	#0000	Com B - Slave#1
3	0	1	0	1	0	1	0	1	0	1	0	1	0	1	0	1	#5555	Com B - Slave#3
4	0	1	0	1	0	1	0	1	0	1	0	1	0	1	0	1	#5555	Com C - Slave#2
5	0	0	0	0	0	0	0	0	0	0	0	0	0	0	0	0	#0000	Com C - Not allocated
6	0	1	0	1	0	1	0	1	0	1	0	1	0	1	0	1	#5555	Com D - Slave#1
7	0	0	0	0	0	0	0	0	0	0	0	0	0	0	0	0	#0000	Com D - Slave#2
8	#D4	#D3	#D2	#D1	#C4	#C3	#C2	#C1	#B4	#B3	#B2	#B1	#A4	#A3	#A2	#A1	#33F7	Slave connected status
	0	0	1	1	0	0	1	1	1	1	1	1	0	1	1	1		
9	Error code												COM_D	COM_C	COM_B	COM_A	#0000	Port diagnostics
	0	0	0	0	0	0	0	0	0	0	0	0	0	0	0	0		

Change Password      Execute      Reset      Force output exit

Offset (INT)	OUTPUT DATA																Hex	Description
	Bit																	
0	15	14	13	12	11	10	9	8	7	6	5	4	3	2	1	0	#5555	Com A - Slave#2
1	0	1	0	0	0	0	0	0	0	0	0	0	0	1	0	1	#0000	Com A - Slave#2
2	0	0	0	0	0	0	0	0	0	0	0	0	0	0	0	0	#0000	Com B - Slave#2
3	0	0	0	0	0	0	0	0	0	0	0	0	0	0	0	0	#0000	Com B - Slave#4
4	0	0	0	0	0	0	0	0	0	0	0	0	0	0	0	0	#0000	Com C - Slave#1
5	0	0	0	0	0	0	0	0	0	0	0	0	0	0	0	0	#0000	Com C - Not allocated
6	0	0	0	0	0	0	0	0	0	0	0	0	0	0	0	0	#0000	Com D - Not allocated
7	0	0	0	0	0	0	0	0	0	0	0	0	0	0	0	0	#0000	Com D - Not allocated
8	#D4	#D3	#D2	#D1	#C4	#C3	#C2	#C1	#B4	#B3	#B2	#B1	#A4	#A3	#A2	#A1	#0000	Enable slave connection errors
	0	0	0	0	0	0	0	0	0	0	0	0	0	0	0	0		
9	Reserved												COM_D	COM_C	COM_B	COM_A	#0000	32out switch diagnostic setting
	-	-	-	-	-	-	-	-	-	-	-	-	-	0	0	0		

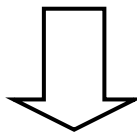

IP Address : 192.168.0.1

EX500-GEN2  
GW Unit for EtherNet/IP

Force output : Active

Module status : Operating Normally

Network status : Not Established



Slave Information

I/O Status

Properties

Offset (INT)	INPUT DATA																Hex	Description
	Bit																	
	15	14	13	12	11	10	9	8	7	6	5	4	3	2	1	0		
0	0	1	0	1	0	1	0	1	0	1	0	1	0	1	0	1	#5555	Com A - Slave#1
1	1	0	1	0	1	0	1	0	1	0	1	0	1	0	1	0	#AAAA	Com A - Slave#3
2	0	0	0	0	0	0	0	0	0	0	0	0	0	0	0	0	#0000	Com B - Slave#1
3	0	1	0	1	0	1	0	1	0	1	0	1	0	1	0	1	#5555	Com B - Slave#3
4	0	1	0	1	0	1	0	1	0	1	0	1	0	1	0	1	#5555	Com C - Slave#2
5	0	0	0	0	0	0	0	0	0	0	0	0	0	0	0	0	#0000	Com C - Not allocated
6	0	1	0	1	0	1	0	1	0	1	0	1	0	1	0	1	#5555	Com D - Slave#1
7	0	0	0	0	0	0	0	0	0	0	0	0	0	0	0	0	#0000	Com D - Slave#2
8	#D4	#D3	#D2	#D1	#C4	#C3	#C2	#C1	#B4	#B3	#B2	#B1	#A4	#A3	#A2	#A1	#33F7	Slave connected status
	0	0	1	1	0	0	1	1	1	1	1	1	0	1	1	1		
9	Error code												COM_D	COM_C	COM_B	COM_A	#0000	Port diagnostics
	0	0	0	0	0	0	0	0	0	0	0	0	0	0	0	0		

Change Password

Execute

Reset

Force output exit

Offset (INT)	OUTPUT DATA																Hex	Description
	Bit																	
	15	14	13	12	11	10	9	8	7	6	5	4	3	2	1	0		
0	0	1	0	1	0	1	0	1	0	1	0	1	0	1	0	1	#5555	Com A - Slave#2
1	0	1	0	0	0	0	0	0	0	0	0	0	0	1	0	1	#4005	Com A - Slave#2
2	0	0	0	0	0	0	0	0	0	0	0	0	0	0	0	0	#0000	Com B - Slave#2
3	0	0	0	0	0	0	0	0	0	0	0	0	0	0	0	0	#0000	Com B - Slave#4
4	0	0	0	0	0	0	0	0	0	0	0	0	0	0	0	0	#0000	Com C - Slave#1
5	0	0	0	0	0	0	0	0	0	0	0	0	0	0	0	0	#0000	Com C - Not allocated
6	0	0	0	0	0	0	0	0	0	0	0	0	0	0	0	0	#0000	Com D - Not allocated
7	0	0	0	0	0	0	0	0	0	0	0	0	0	0	0	0	#0000	Com D - Not allocated
8	#D4	#D3	#D2	#D1	#C4	#C3	#C2	#C1	#B4	#B3	#B2	#B1	#A4	#A3	#A2	#A1	#0000	Enable slave connection errors
	0	0	0	0	0	0	0	0	0	0	0	0	0	0	0	0		
9	Reserved												COM_D	COM_C	COM_B	COM_A	#0000	32out switch diagnostic setting
	-	-	-	-	-	-	-	-	-	-	-	-	-	0	0	0		

All output data can be cleared by selecting "Reset".  
 Forced output mode is released by selecting "Force output exit".  
 At this time, the output data is automatically cleared.

●Password change

Password can be changed by selecting the Change password button.

Type the password before change in the Old password space, and the new password in the New password and Confirm password spaces. Password change is completed by selecting OK.

IP Address : 192.168.0.1      EX500-GEN2      Force output : Inactive  
 Module status : **Operating Normally**      GW Unit for EtherNet/IP      Network status : **Not Established**      

Slave Information | **I/O Status** | Properties

Offset (INT)	INPUT DATA																Hex	Description
	15	14	13	12	11	10	9	8	7	6	5	4	3	2	1	0		
0	0	1	0	1	0	<div style="border: 1px solid gray; padding: 5px;">           Change password for output forcing?             Old password : <input type="text"/>             New password : <input type="text"/>             Confirm password : <input type="text"/>   <input type="button" value="OK"/> <input type="button" value="Cancel"/> </div>											#5555	Com A - Slave#1
1	1	0	1	0	1												#AAAA	Com A - Slave#3
2	0	0	0	0	0												#0000	Com B - Slave#1
3	0	1	0	1	0												#5555	Com B - Slave#3
4	0	1	0	1	0												#5555	Com C - Slave#2
5	0	0	0	0	0												#0000	Com C - Not allocated
6	0	1	0	1	0												#5555	Com D - Slave#1
7	0	0	0	0	0												#0000	Com D - Slave#2
8	#D4	#D3	#D2	#D1	#C4												#33F7	Slave connected status
9	0	0	0	0	0												#0000	Port diagnostics

Change Password      Reset      Force output

Offset (INT)	OUTPUT DATA																Hex	Description
	15	14	13	12	11	10	9	8	7	6	5	4	3	2	1	0		
0	0	0	0	0	0	0	0	0	0	0	0	0	0	0	0	0	#0000	Com A - Slave#2
1	0	0	0	0	0	0	0	0	0	0	0	0	0	0	0	0	#0000	Com A - Slave#2
2	0	0	0	0	0	0	0	0	0	0	0	0	0	0	0	0	#0000	Com B - Slave#2
3	0	0	0	0	0	0	0	0	0	0	0	0	0	0	0	0	#0000	Com B - Slave#4
4	0	0	0	0	0	0	0	0	0	0	0	0	0	0	0	0	#0000	Com C - Slave#1
5	0	0	0	0	0	0	0	0	0	0	0	0	0	0	0	0	#0000	Com C - Not allocated
6	0	0	0	0	0	0	0	0	0	0	0	0	0	0	0	0	#0000	Com D - Not allocated
7	0	0	0	0	0	0	0	0	0	0	0	0	0	0	0	0	#0000	Com D - Not allocated
8	#D4	#D3	#D2	#D1	#C4	#C3	#C2	#C1	#B4	#B3	#B2	#B1	#A4	#A3	#A2	#A1	#0000	Enable slave connection errors
9	Reserved												COM_D	COM_C	COM_B	COM_A	#0000	32out switch diagnostic setting

**< CAUTION >**

- Valid character for password is half-width alphanumeric and "-", "\_", "." and "@".
- Maximum number of characters for password is 16.
- Changed password must be strictly controlled.
- If the password is forgotten and needs to be reset, CIP Object Reset service command can initialize the password.

Service	Class ID	Inst ID	Attr ID	Values
Reset	01 h [Identity Object]	1 h	-	01 (Type1 reset)

< Properties tab >

Network information including the GW unit MAC address and communication speed are displayed.

IP Address :  EX500-GEN2  
GW Unit for EtherNet/IP

Force output :

Module status :  Network status :



Slave Information | I/O Status | **Properties**

Network Interface	
Ethernet Address(MAC)	00:23:C6:19:AB:CD
IP Address	192.168.0.1
SubnetMask	255.255.255.0
DefaultGateway	0.0.0.0

Ethernet Port 1	
Interface label	ETH-PHY1
Link Status	Active
Speed	100Mbps
Duplex	Full duplex
Negotiate Status	Successfully negotiated speed and duplex

Ethernet Port 2	
Interface label	ETH-PHY2
Link Status	Inactive
Speed	0Mbps
Duplex	Half duplex
Negotiate Status	Auto negotiation in progress

Copyright © SMC Corporation. All Rights Reserved.



# Specification

## ■ Specifications

### Basic Specifications

Item	Specifications
Power supply voltage range	Power supply for input and control: 24 VDC $\pm 10\%$ * Power supply for solenoid valve: 24 VDC $+10\%/-5\%$ *
Rated current	Power supply for input and control: 6.2 A (GW unit internal current consumption: 200 mA or less) Power supply for solenoid valve: 4 A
Number of inputs and outputs	Input: Max. 128 points/Output: Max. 128 points
Standard	CE marking, UL(CSA), RoHS
Weight	550 g

\*: The direct current power supply to combine should be UL1310 class 2 power supply when conformity to UL is necessary.

### Environment specifications

Item	Specifications
Enclosure rating	IP65
Body material	PBT
Operating temperature range	Operation: $-10$ to $50$ °C, Storage: $-20$ to $60$ °C (No condensation or freezing)
Operating humidity range	Operation, Storage: 35 to 85%RH (No condensation)
Operating atmosphere	No corrosive gas

### Communication specifications

Item	Specifications
Protocol	Ethernet (IEEE802.3)
Media	100BASE-TX (CAT5 or more)
Communication speed	10/100 Mbps (Automatically selected)
Communication method	Full duplex / half duplex (automatically selected)
Fieldbus protocol	EtherNet/IP™
I/O Message	Input: 20 bytes (assembly instance: 100) Output: 20 bytes (assembly instance: 150)
IP address setting range	Setting of specified address by DHCP server or internal switch. (192.168.0.1 to 192.168.0.254, 192.168.1.1 to 192.168.1.254)
Device information	Vendor ID: 7 (SMC Corp.) Product type: 12 (Communication adapter) Product code: 198
Applicable function	Quick Connect™ DLR Web server (Applicable browser: Internet Explorer6 to 11, Firefox28.0 to 31.0, Google Chrome 36.0 to 37.0)



### Branch port specifications

Item	Specifications
Number of inputs and outputs	128 Inputs/128 Outputs
Applicable system	Gateway distribution system 2 (128 point)
Number of branch port	4 (Input: Max. 32 points/Output: Max. 32 points per branch)
Number of connected slave	Max. 16 (Input unit: 2 pcs./SI unit: 2 pcs. per branch)
Power supply for input equipment and control	24 VDC, Max. 1.5 A per one branch port
Power supply for Solenoid valve	24 VDC, Max. 1.0 A per one branch port
Branch cables	Cable with M12 connector made by SMC (EX500-AC□□□-S□P□)
Branch cable length	Total length 20 m or less per branch

## ■Dimensions

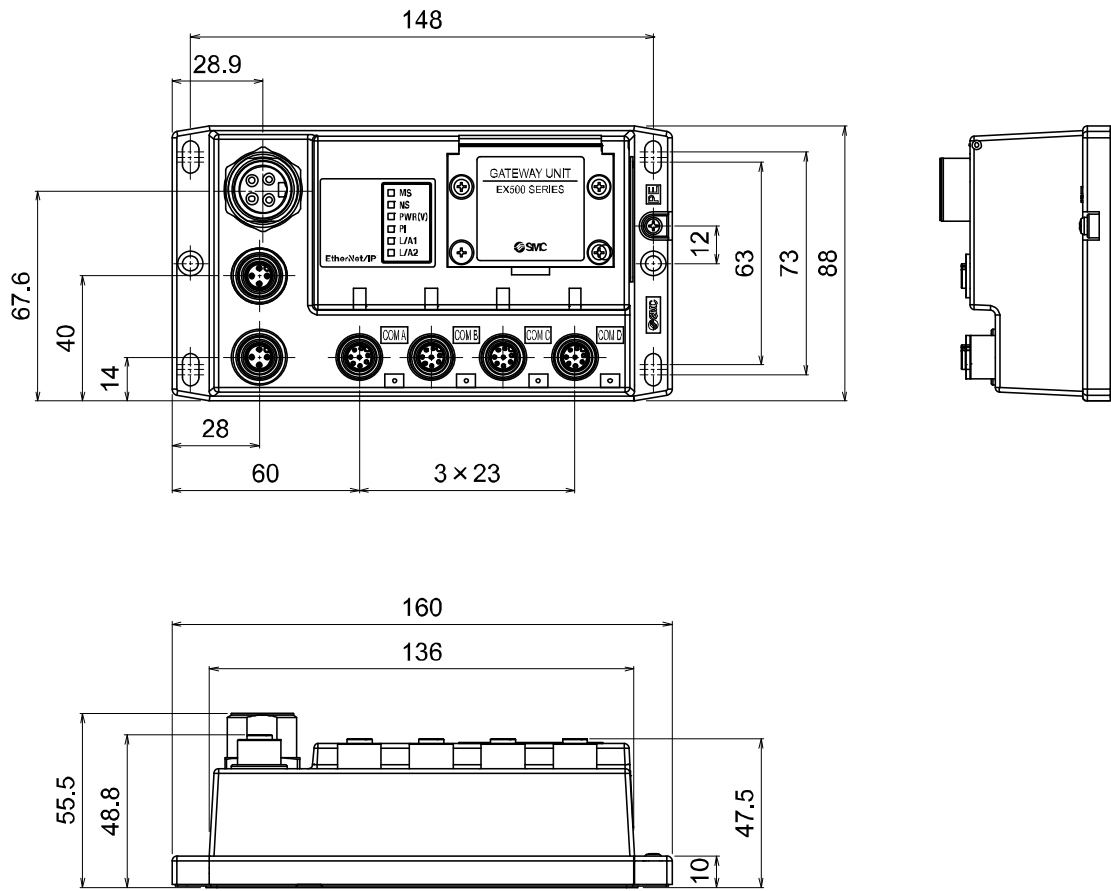

# SI unit

## Model Indication and How to Order

EX500-S 1 03

• Output type

1	Source/PNP (negative common)
---	------------------------------

## Summary of Product parts

SI unit is combined with the manifold valve to communicate with GW unit.

The EX9 series general output block can be connected with the SI unit to operate the solenoid valve or relays.

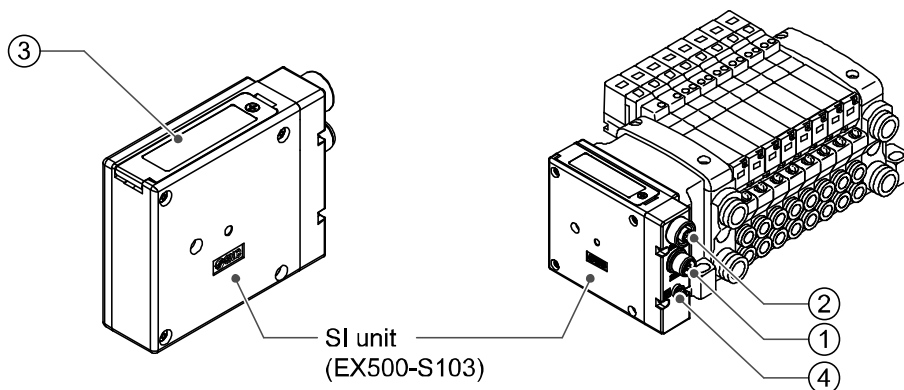

No.	Description	Application
1	Branch connector (IN)	Connector for branch cable (with M12 connector) from the GW unit. *1
2	Branch connector (OUT)	Connector for branch cable (with M12 connector) to the next unit on the branch line. *1
3	Display and switch setting cover	LED display to indicate the SI unit status. *2 Set the output points using the switches under the cover.
4	Grounding terminal (FE)	Used for functional grounding. (M3 thread) (It is recommended to ground with resistance of 100 ohms or less)

### Accessories

Hexagon socket head cap screw (M3 x 30): 2 pcs.	Connects the SI unit and the valve manifold.
Seal cap: 1 pc. (for M12 connector socket)	For unused branch connector (OUT).

\*1: Refer to page 12 for wiring.

\*2: Refer to page 47 for display

## Mounting and Installation

### ■ Installation

Refer to the drawing below.

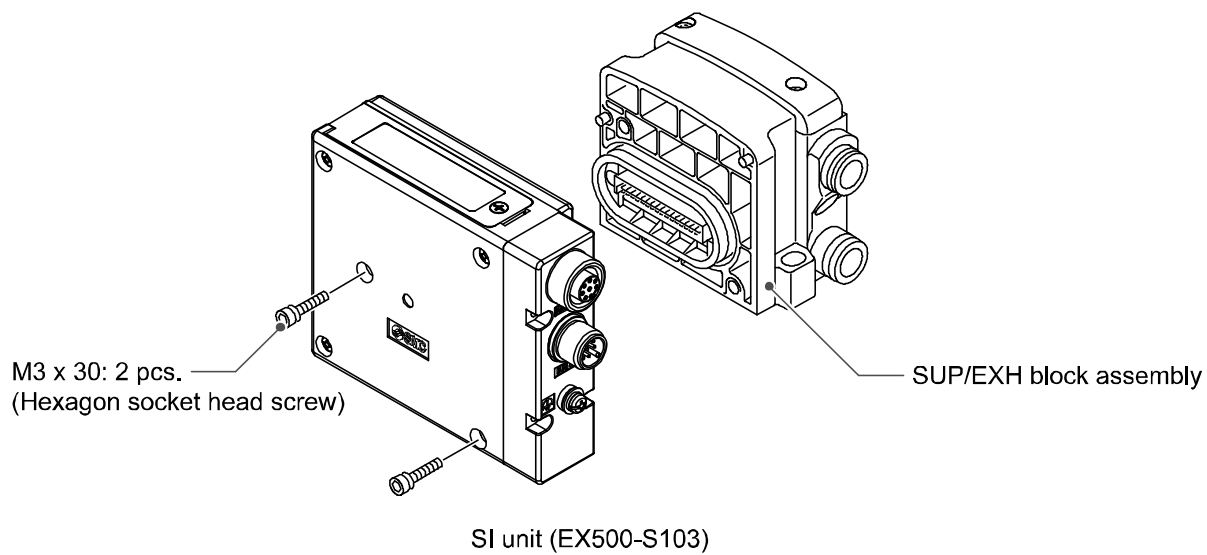

#### NOTE

Tighten the screws while holding the SI unit and the supply/exhaust block assembly so that there is no gap between them. Tighten the screws with the tightening torque specified.  
(Tightening torque: 0.6 Nm)

\*: Refer to the catalogue and the operation manuals for details of the installation of the solenoid valve and manifold.

○Ground connection

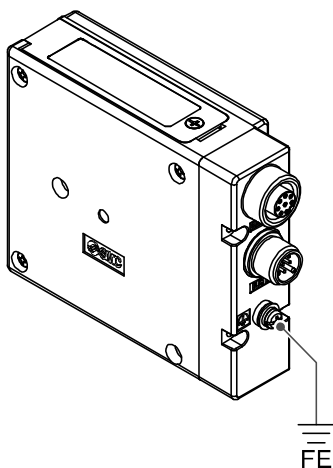

**NOTE**

Connect the FE terminal to ground.

○Output No. assignment

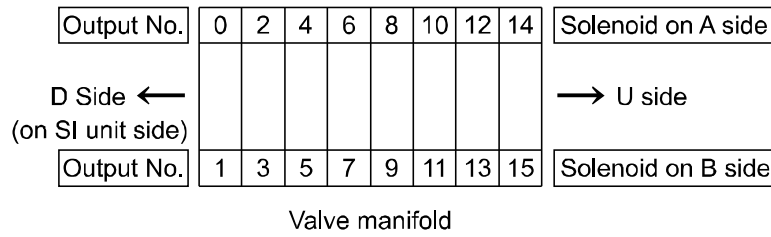

\*: Output No. starts from 0, and will be assigned to the valves in order from the SI unit mounted side (D side).

\*: Standard wiring on the manifold is for double-solenoid valves and output number starts A side and B side in that order. If the mounted valves are single solenoid valves, the output on B side will be empty. (See fig. a)

\*: Special wiring specification with a mixed wiring of single solenoid and double solenoid can be specified with a wiring specification sheet. This makes it possible to specify the output numbers without empty outputs. (See fig. b)

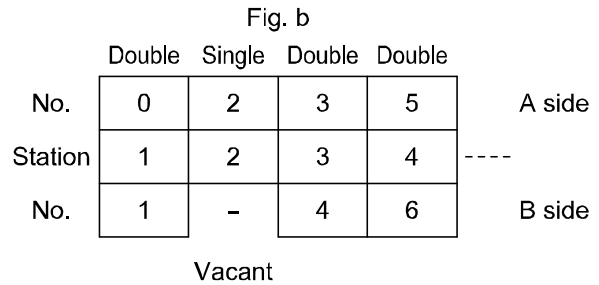
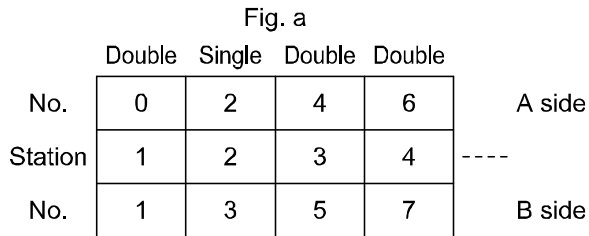

## ■ Separate power supply

It is possible to provide a separate power supply to the SI unit and valves using a Y branch connector.

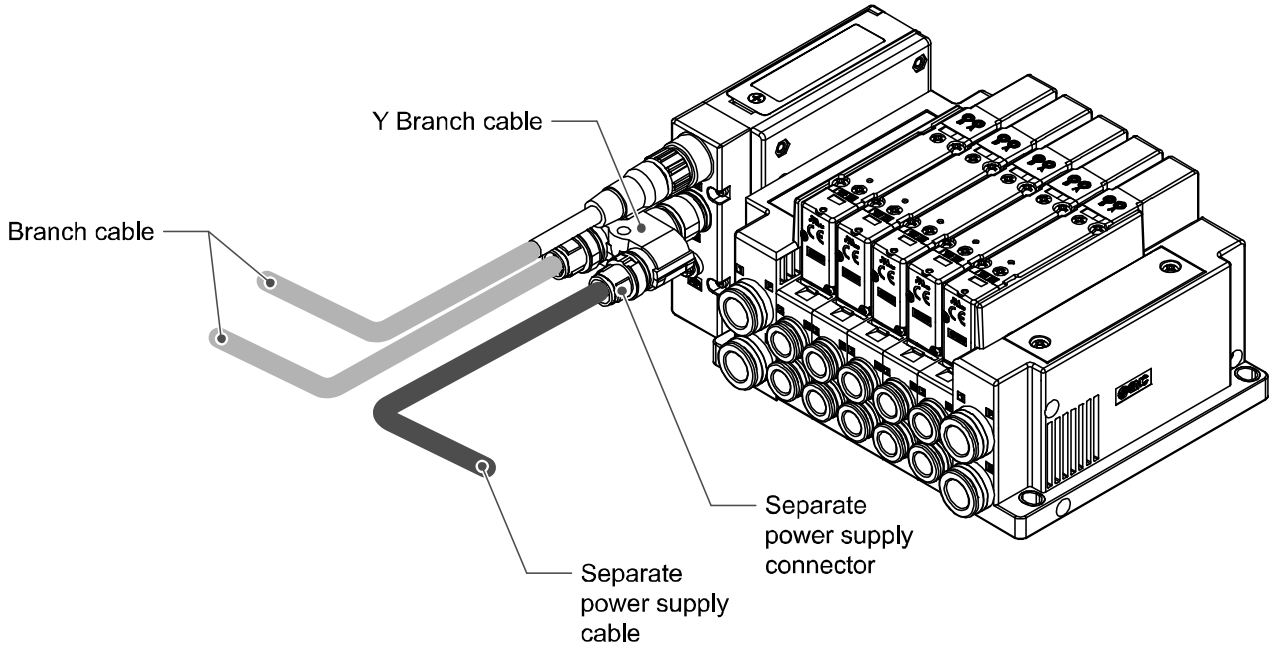

### Separate connector pin layout

M12, 4 pin, plug

No.	Description	
1	24 VDC (For solenoid valves)	
2	0 VDC (For solenoid valves)	
3	Unused	
4	Unused	

\*: Refer to page 73 for Y branch connector.

# LED Display and Settings

## •LED display

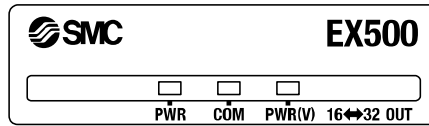

Display	Meaning	
PWR	LED is OFF	The power supply for input and control is OFF
	Green LED is ON	Power supply for input and control is ON
COM	LED is OFF	Communication error between GW unit has occurred
	Green LED is ON	Communication between GW unit is normal
PWR(V)	LED is OFF	Power supply for solenoid valve is OFF
	Green LED is ON	Power supply for solenoid valve is ON

## •Switch setting

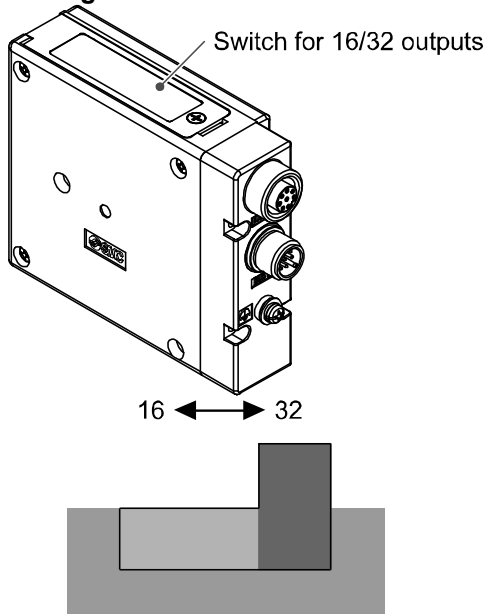

Number of outputs

	Meaning
16	16 output
32	32 output

\*: The default setting is 32.



# Specification

## Specifications

Item	Specifications
Output type	PNP (negative common)
Number of outputs	32 points (Internal switch for selecting 16 point or 32 point)
Connected load	Solenoid valve with surge voltage suppressor of 24 VDC and 1.0 W or less (manufactured by SMC)
Short circuit protection	Applicable
Load current	Max power supply of GW unit 1.0 A, Max. external power supply 1.5 A
Internal current consumption	50 mA or less
Enclosure rating	IP67
Body material	PBT
Operating temperature range	Operation: -10 to 50 °C, Storage: -20 to 60 °C (No condensation or freezing)
Operating humidity range	Operation, Storage: 35 to 85%RH (No condensation)
Operating atmosphere	No corrosive gas
Standard	CE marking, UL(CSA), RoHS
Weight	200 g
System	Gateway distribution system 2 (128 point)

### Applicable valve series

Refer to the catalogue and the operation manuals for details of the specifications of the solenoid valve and manifold.

Valve series	
SV series	SV1000, SV2000, SV3000
SY series	SY3000, SY5000, SY7000
VQC series	VQC1000, VQC2000, VQC4000
S0700 series	S0700

### Power supply voltage for Solenoid valve

Voltage drop may occur to the source voltage supplied via the SI unit to the valve due to the power consumption of the valves and the length of the branch cable.

Refer to the guidelines of the Solenoid Valve Power Supply Voltage Drop below.

\*: Y connector is also available depending on your usage.

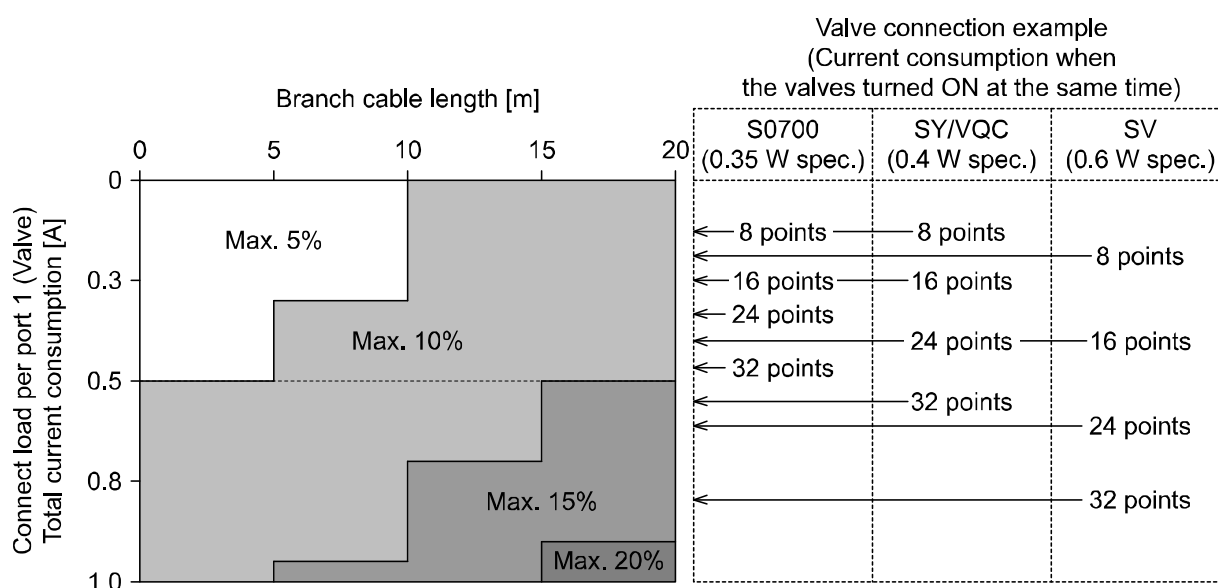

< Guideline of the Solenoid Valve Power Supply Voltage Drop >

## ■Dimensions

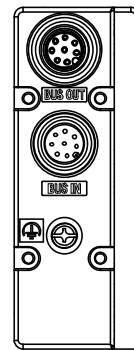
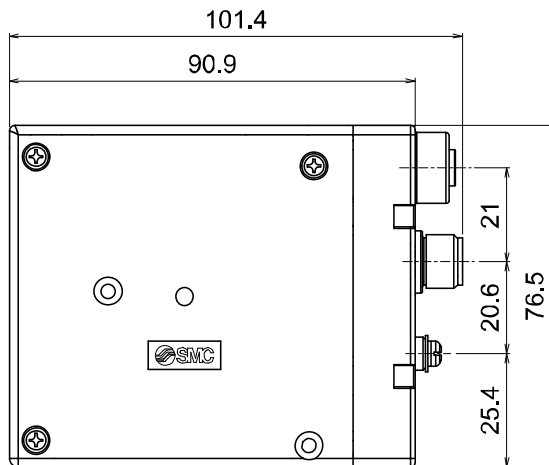
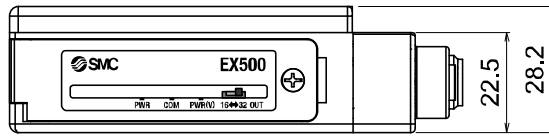

# Input unit

## Model Indication and How to Order

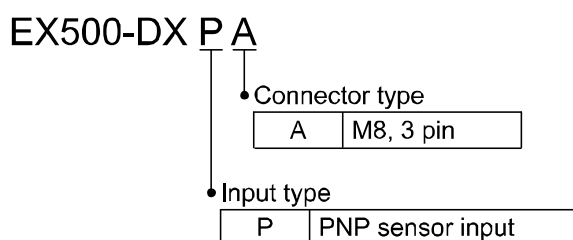

## Summary of Product parts

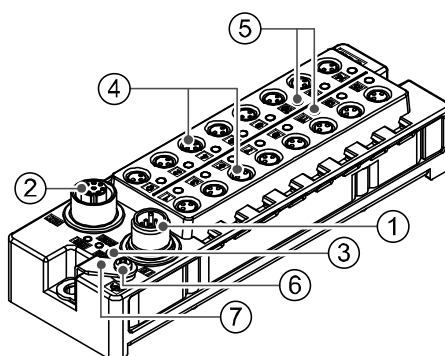

No.	Description	Application
1	Branch connector (IN)	Connector for branch cable (with M12 connector) from the GW unit. *1
2	Branch connector (OUT)	Connector for branch cable (with M12 connector) to the next unit on the branch line. *1
3	Display LED	LED display to indicate the input status. *2
4	Sensor connector	Connector for sensor. *1
5	Display LED	Displays the sensor signal status. *2
6	Grounding terminal	Used for functional grounding. (M3 thread) (It is recommended to ground with resistance of 100 ohms or less)
7	Grounding bracket	Connect the mounting hole to the grounding terminal

### Accessories

Seal cap: 1 pc. (for M12 connector socket)	For unused branch connector (OUT).
Seal cap: 16 pcs. (for M8 connector socket)	Used for unused sensor connector.

\*1: Refer to page 12 for wiring.

\*2: Refer to page 55 for display.

# Mounting and Installation

## ■ Installation

### ● Direct mounting

Install the product using 2 M4 screws x 20 mm or longer with a head  $\varnothing 8$  minimum.

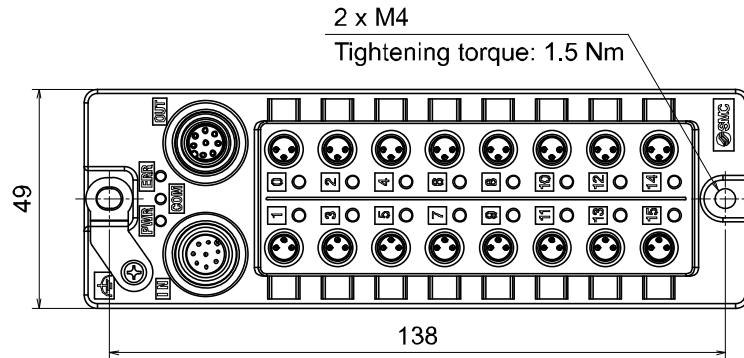

## ■Wiring

### ●Branch wiring

Connect the branch cable to the branch connector (IN/OUT). Refer to page 12 for wiring.

### ●Sensor wiring

Connect the sensors to the sensor connectors.

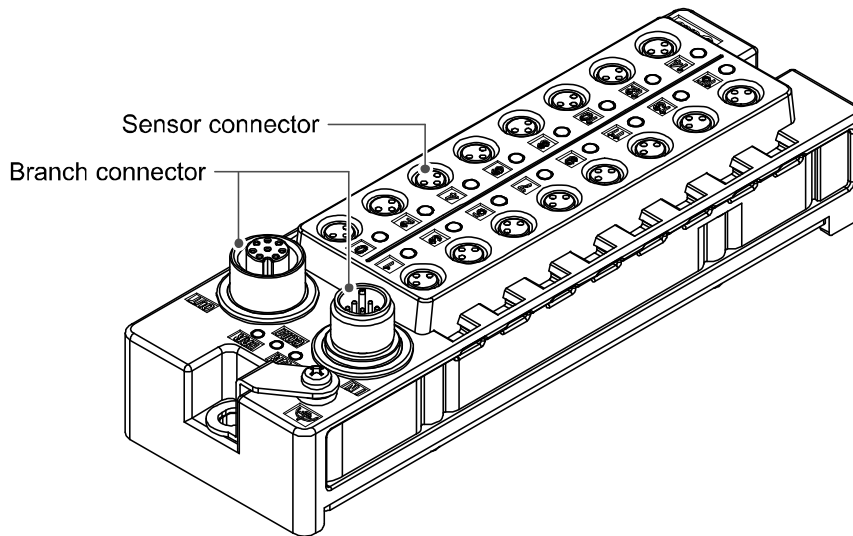

### Pin layout of the sensor connector

M8 connector (3 pin, socket)

No.	Description	
1	Power supply (24 VDC)	1
3	Power supply (0 V)	4
4	Input	3

A circular diagram representing the M8 connector's pin layout. It shows three pins arranged in a triangle. The top pin is labeled '1', the bottom-left pin is labeled '4', and the bottom-right pin is labeled '3'.

#### NOTE

Be sure to fit a seal cap on any unused connectors of the input block.  
IP67 is maintained by using the seal cap.  
(Tightening torque for M8: 0.05 Nm, M12: 0.1 Nm)

- Sensor wiring example
- PNP input

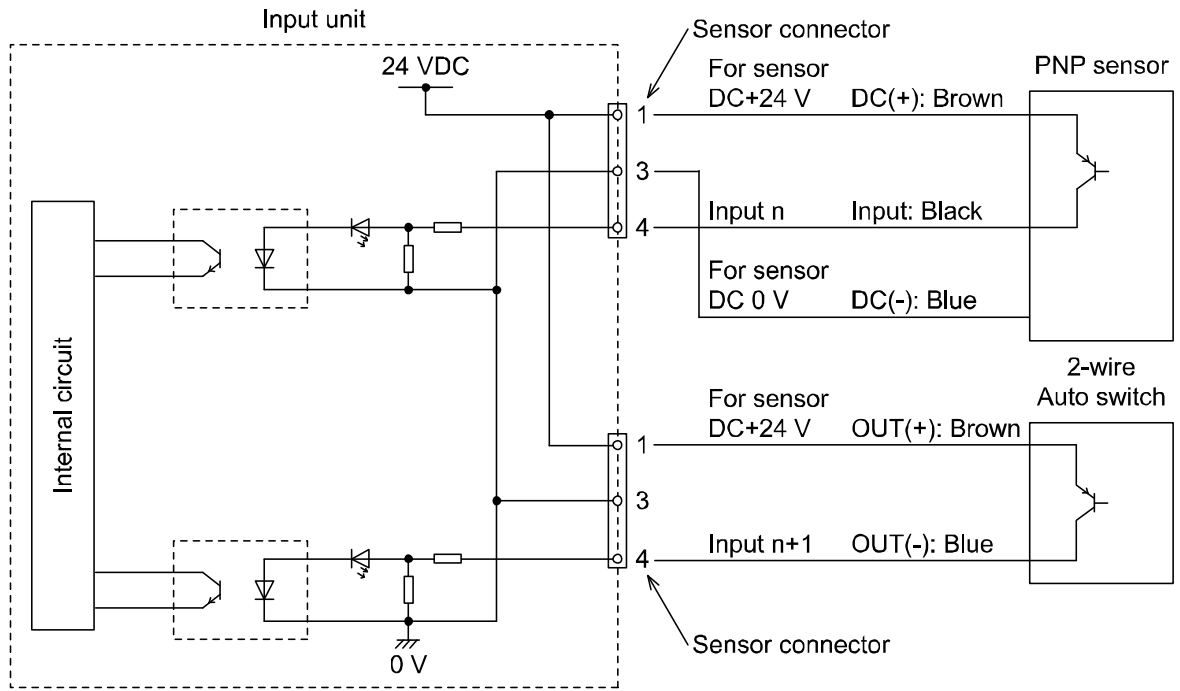

- Correspondence between the input number and input

The input number is assigned from 0 to 15 from the branch connector side.

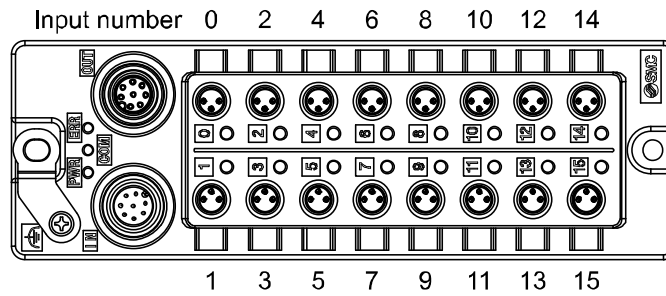

○Ground connection

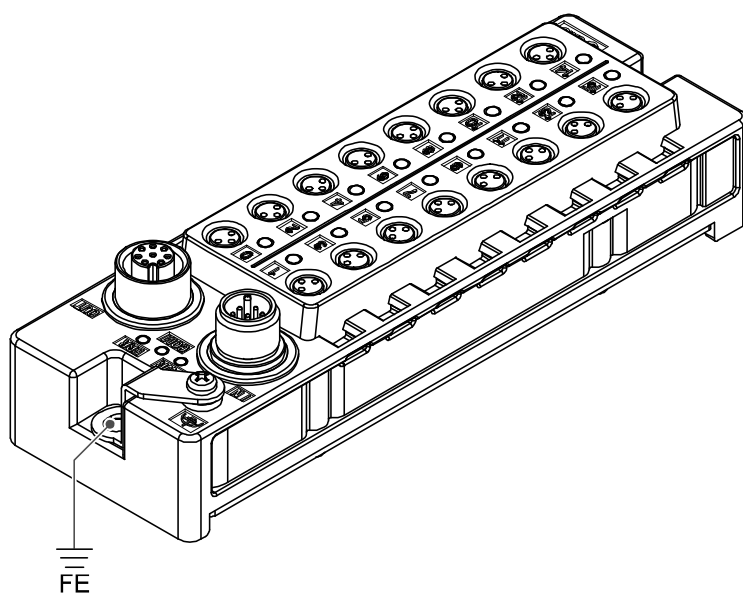

The mounting hole at the branch connector side is connected to the ground terminal using the grounding bracket.

**NOTE**

Connect the FE terminal to ground.

## LED Display

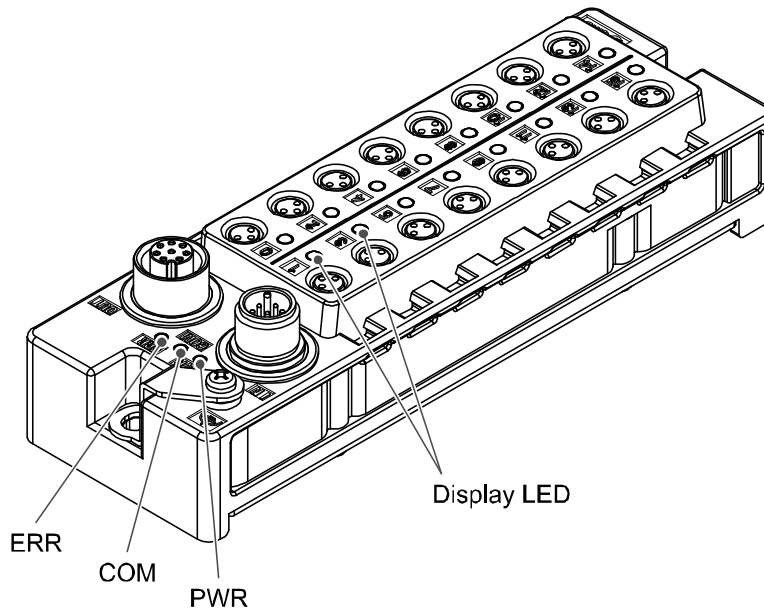

Display	Meaning	
PWR	LED is OFF	The power supply for input and control is OFF
	Green LED is ON	Power supply for input and control is ON
COM	LED is OFF	Communication error between GW unit has occurred
	Green LED is ON	Communication between GW unit is normal
ERR	LED is OFF	Normal operation
	Red LED is ON	Short circuit detection
Display LED	LED is OFF	Sensor signal input is OFF
	Green LED is ON	Sensor signal input is ON



# Specification

## ■ Specifications

Item	Specifications
Input type	PNP sensor input
Number of inputs	16
Voltage for input equipment	24 VDC
Current for input equipment	Max. 1.3 A/unit (Total of 8 connectors of even number must be Max. 0.65 A, 8 connectors of odd number must be Max. 0.65 A)
Input ON voltage/input ON current	11 V or more/Typ.7 mA (at 24 VDC)
Input OFF voltage/input OFF current	5 V or less/1.5 mA or less (at 24 VDC)
Rated input current	Approx. 7 mA
Internal current consumption	200 mA or less (when the input signal is ON)
Display	Green LED (Lights when ON)
Sensor connector	M8 connector (3 pin, socket)
Short circuit protection	Available
Enclosure rating	IP67
Body material	PBT
Operating temperature range	Operation: -10 to 50 °C, Storage: -20 to 60 °C (No condensation or freezing)
Operating humidity range	Operation, Storage: 35 to 85%RH (No condensation)
Operating atmosphere	No corrosive gas
Standard	CE mark, UL(CSA), RoHS
Weight	250 g
System	Gateway distribution system 2 (128 point)

### Power supply voltage for input and control

Voltage drop may occur to the source voltage supplied from the input unit to the sensor due to the connected unit, power consumption of the sensor or the length of the branch cable.

Refer to the Guideline of the Voltage Drop of the Power Supply for Input and Control below.

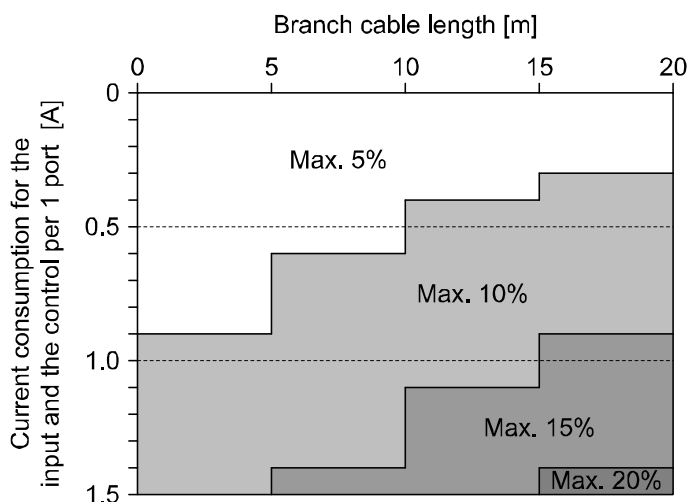

< Guideline of the Voltage Drop of the Power Supply for Input and Control >

## ■Dimensions

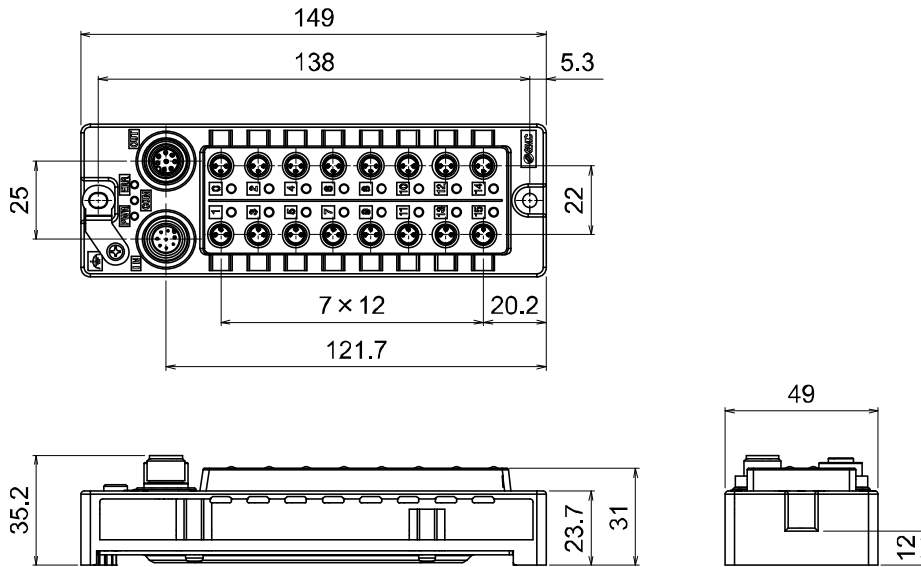

## Interchangeability of system

**Mixed usage Gateway distribution system 2 (128 points) and gateway distribution system (64 points)**  
EX500-GEN2, EX500-S103, EX500-DXPA are products for gateway distribution system 2 (128 points).

Although it is possible to use with existing 64 point gateway distribution system, the operating condition must comply with the specifications of the 64 point gateway system.

		GW unit	
		Gateway distribution system 2 (128 points) •EX500-GEN2	Gateway distribution system (64 points) •EX500-GDN1 •EX500-GPR1A
SI unit Input unit	Gateway distribution system 2 (128 points) •EX500-S103 •EX500-DXPA	Usable	Usable *:Same specifications of gateway distribution system (64 point)
	Gateway distribution system (64 points) •EX500-S001 •EX500-Q□01 •EEX500-IB1-□	Usable *:Same specifications of gateway distribution system (64 point)	Usable

### •Specifications of gateway distribution system (64 point)

Item		Specifications
Number of inputs and outputs		64 input (16 input per branch) 64 output (16 output per branch)
Number of occupied slave		Max. 8 (Input unit: 1 pc./SI unit: 1 pc. per branch)
Rated current	GW unit	Power supply for input and control: 3.0 A Power supply for Solenoid valve: 3.0 A
	Input unit	Max. 0.5 A/unit
	SI unit	Max. 0.75 A/ unit
Branch cable length		Total length 10 m or less per branch

**GW unit using SI unit for 64 point gateway distribution system and input unit.**

If EX500-GEN2 DIP switch No.3 is turned on, the unit starts up with the specifications of 64 point gateway distribution system and it is possible to use with 64 point gateway distribution system.

\*: Diagnostic function of the gateway distribution system 2 (128 points) cannot be used.

DIP SW

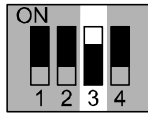

Method to connect GW unit to Rockwell Automation EtherNet/IP™ module (master) is shown below. Refer to the Operation Manual of the RSLogix5000™ for the detailed operation.

\*: This figure shows the display of Rockwell Automation software, RSLogix5000™.

- Select [EtherNet/IP™ module] in [I/O Configuration] folder, then select [New Module].

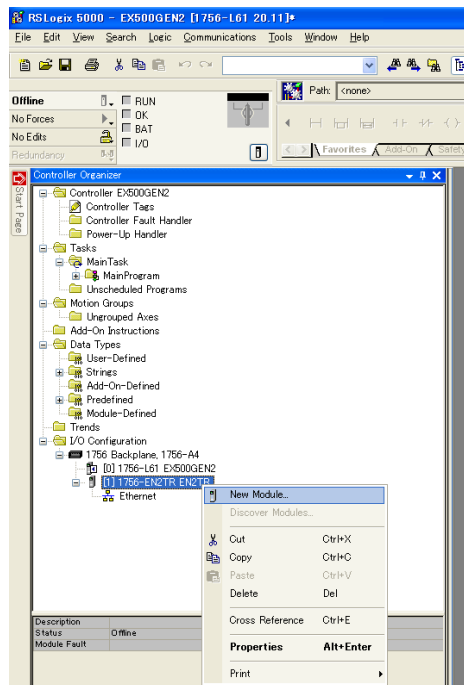

- The [Select Module] screen is displayed. Select [ETHERNET-MODULE Generic Ethernet Module], then select [Create].

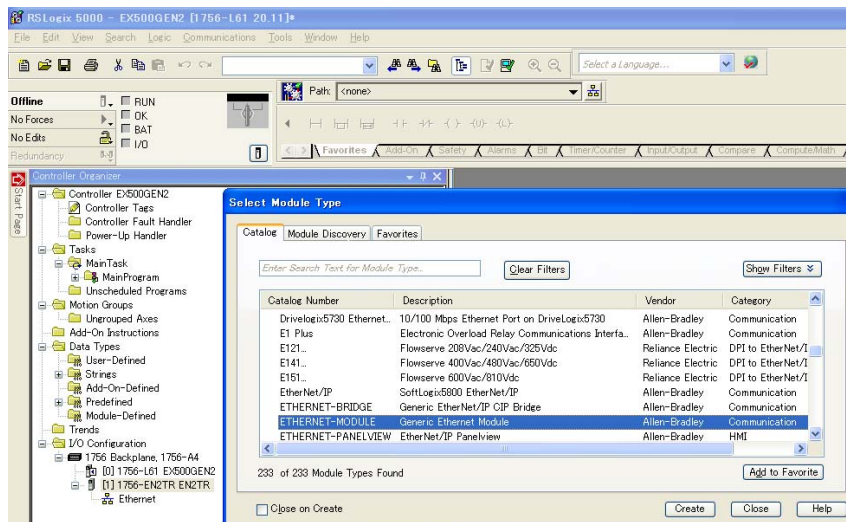

•[Module Properties] screen is displayed. Perform each setting.

- (1) Name: Enter the required unit name.
- (2) Comm Format: Select the data format of Connection Parameters.
- (3) IP Address: Enter the IP address setting for the SI unit.
- (4) Assembly Instance: Perform setting as shown below.

Item	Decimal	
	"Data-INT"	"Data-SINT"
Common Format	"Data-INT"	"Data-SINT"
Input	100	100
Output	150	150
Configuration	130	130

(5) Size: Perform setting as shown below.

Item	Decimal	
	"Data-INT"	"Data-SINT"
Common Format	"Data-INT"	"Data-SINT"
Input	8(words)	16(bytes)
Output	8(words)	16(bytes)
Configuration	0(words)	0 (bytes)

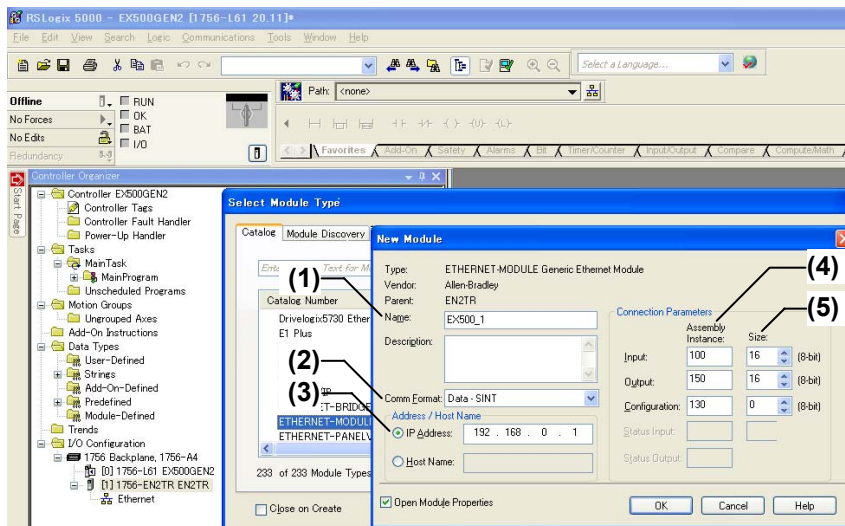

•I/O memory map for 64 points gateway distribution system mode

Input data

Offset (INT)	Input data																Meaning	
	MSB								LSB									
	15								8									
0	IN15	IN14	IN13	IN12	IN11	IN10	IN9	IN8	IN7	IN6	IN5	IN4	IN3	IN2	IN1	IN0	COM A	
1	IN31	IN30	IN29	IN28	IN27	IN26	IN25	IN24	IN23	IN22	IN21	IN20	IN19	IN18	IN17	IN16	COM B	
2	IN47	IN46	IN45	IN44	IN43	IN42	IN41	IN40	IN39	IN38	IN37	IN36	IN35	IN34	IN33	IN32	COM C	
3	IN63	IN62	IN61	IN60	IN59	IN58	IN57	IN56	IN55	IN54	IN53	IN52	IN51	IN50	IN49	IN48	COM D	
4	0	0	0	0	0	0	0	0	0	0	0	0	0	0	0	0	Reserved	
5	0	0	0	0	0	0	0	0	0	0	0	0	0	0	0	0	Reserved	
6	0	0	0	0	0	0	0	0	0	0	0	0	0	0	0	0	Reserved	
7	0	0	0	0	0	0	0	0	0	0	0	0	0	0	0	0	COM D COM C COM B COM A	Port Status

0: Fixed to 0

< Port condition >

Value	Status
0	Connection port
1	Not connected

Output data

Offset (INT)	Output data																Meaning
	MSB								LSB								
	15								8								
0	OUT15	OUT14	OUT13	OUT12	OUT11	OUT10	OUT9	OUT8	OUT7	OUT6	OUT5	OUT4	OUT3	OUT2	OUT1	OUT0	COM A
1	OUT31	OUT30	OUT29	OUT28	OUT27	OUT26	OUT25	OUT24	OUT23	OUT22	OUT21	OUT20	OUT19	OUT18	OUT17	OUT16	COM B
2	OUT47	OUT46	OUT45	OUT44	OUT43	OUT42	OUT41	OUT40	OUT39	OUT38	OUT37	OUT36	OUT35	OUT34	OUT33	OUT32	COM C
3	OUT63	OUT62	OUT61	OUT60	OUT59	OUT58	OUT57	OUT56	OUT55	OUT54	OUT53	OUT52	OUT51	OUT50	OUT49	OUT48	COM D
4	-	-	-	-	-	-	-	-	-	-	-	-	-	-	-	-	Reserved
5	-	-	-	-	-	-	-	-	-	-	-	-	-	-	-	-	Reserved
6	-	-	-	-	-	-	-	-	-	-	-	-	-	-	-	-	Reserved
7	-	-	-	-	-	-	-	-	-	-	-	-	-	-	-	-	Reserved

-: Unused

# Troubleshooting

## Troubleshooting flow chart

When any serial system failure occurs, perform the following trouble shooting.

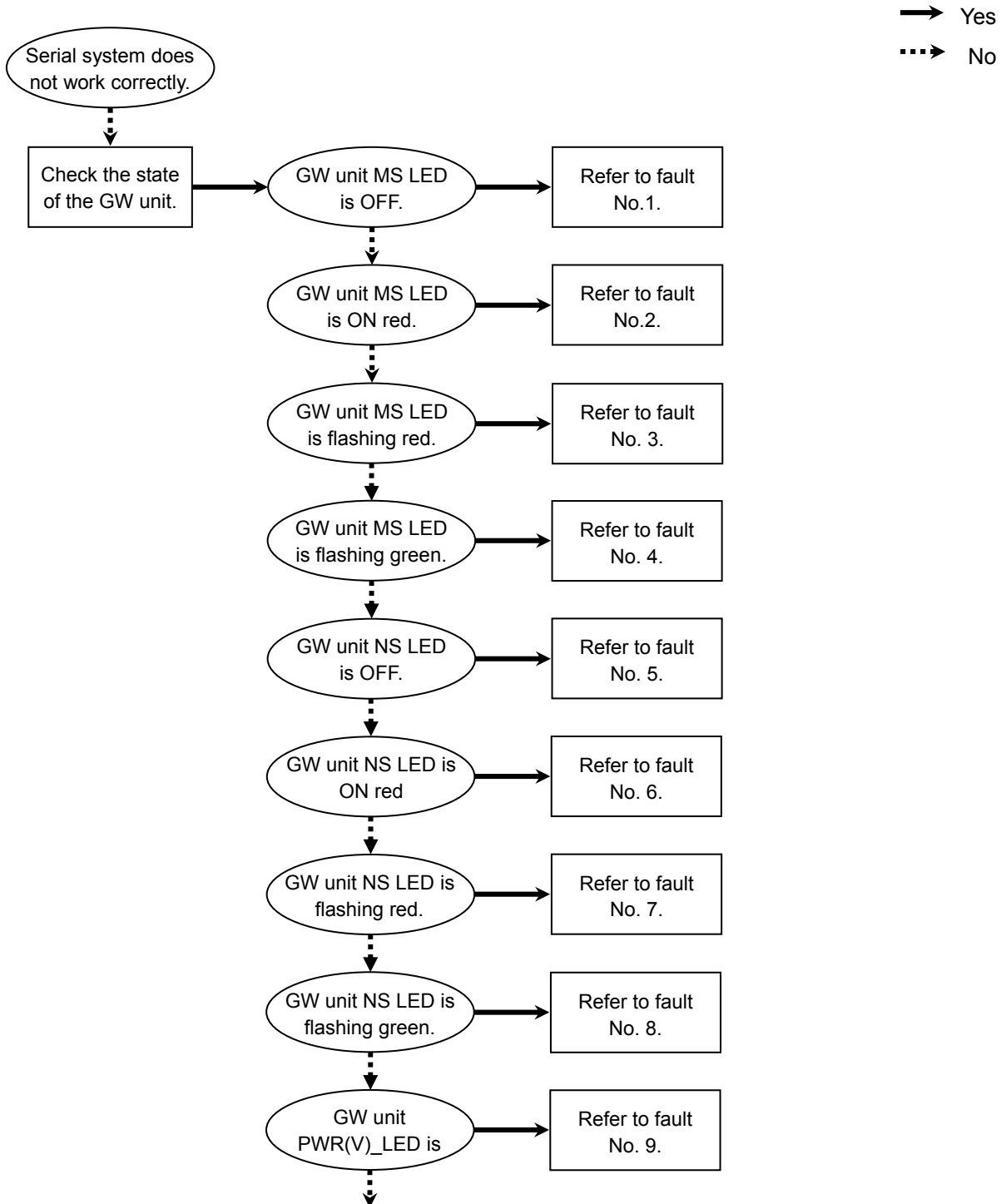

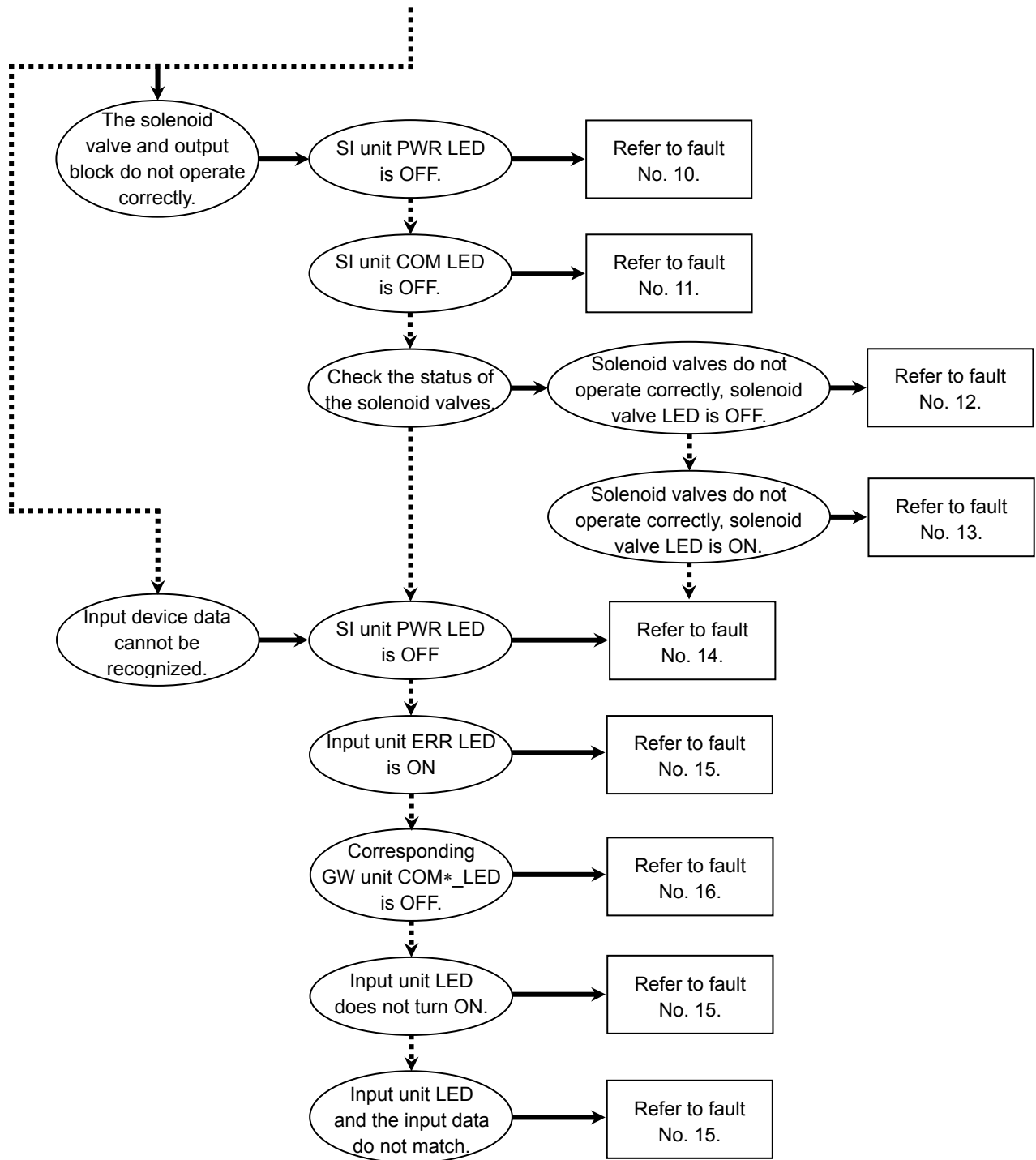



## Troubleshooting

### Fault No. 1

Fault	Possible cause	Investigation method	Countermeasures
GW unit MS LED is OFF.	Wiring of the power supply for input and control is defective	Check the power supply cable connections and check for broken wires.	Tighten the power supply cable connection. (if there is a broken wire, replace the cable).
			Correct the power cable wiring layout.
	Incorrect power supply for input and control	Check the supply voltage for input and control.	Supply 24 VDC $\pm$ 10% to the power supply for control and inputs of the product.

### Fault No. 2

Fault	Possible cause	Investigation method	Countermeasures
GW unit MS LED is ON red	Malfunction of the GW unit	-	Contact your sales representative.

### Fault No. 3

Fault	Possible cause	Investigation method	Countermeasures
GW unit MS LED is flashing red.	Diagnostics error detected	Check the meaning of diagnostic error.	Solve the diagnostic error.

### Fault No. 4

Fault	Possible cause	Investigation method	Countermeasures
GW unit MS LED is flashing green.	Parameter setting error	-	Contact your sales representative.

### Fault No. 5

Fault	Possible cause	Investigation method	Countermeasures
GW unit NS LED is OFF.	No IP address	Check the communication cable connections and check for broken wires.	Tighten the communication cable connection. (if there is a broken wire, replace the cable)
		Wait for the IP address to be set by the DHCP server.	Set the IP address using the DHCP server.

Fault No. 6

Fault	Possible cause	Investigation method	Countermeasures
GW unit NS LED is ON red	IP address has been duplicated	Check that the IP address has not been duplicated on another slave unit.	Set the IP address so that it is not duplicated.

Fault No. 7

Fault	Possible cause	Investigation method	Countermeasures
GW unit NS LED is flashing red.	EtherNet/IP connection time out	Check the communication cable connections and check for broken wires.	Tighten the communication cable connection. (if there is a broken wire, replace the cable)
		Check that the communication cable length is within the maximum specified length. Check that the recommended cable for EtherNet has been used. Check that the communication cable wiring is correct.	Wire the communication cable according to the EtherNet wiring specifications.
		Check that there is no noise source or high voltage line around the EtherNet™ cables and power cables.	Separate the communication and power supply cables away from noise sources.

Fault No. 8

Fault	Possible cause	Investigation method	Countermeasures
GW unit NS LED is flashing green.	Waiting for connection to be established.	Check the address and communication setting.	Review the setting of the switch and address.
		Check the communication cable connections and check for broken wires.	Tighten the communication cable connection. (if there is a broken wire, replace the cable)
		Check if the PLC is operating normally.	Review the setting of PLC.

Fault No. 9

Fault	Possible cause	Investigation method	Countermeasures
GW unit PWR(V)_LED is OFF.	Wiring of the solenoid valve power supply is defective.	Check the power supply cable connections and check for broken wires.	Tighten the power supply cable connection. (if there is a broken wire, replace the cable)
	Solenoid valve power supply failure	Check proper supply voltage of solenoid valve power supply.	Correct the power cable wiring layout. Power supply for solenoid valves: 24 VDC +10%/-5%

Fault No. 10

Fault	Possible cause	Investigation method	Countermeasures
SI unit PWR LED is OFF.	Power supply for input and control: 24 VDC $\pm$ 10%	Check the branch cable connections and check for broken wires.	Tighten the branch cable connection. (if there is a broken wire, replace the cable)

Fault No. 11

Fault	Possible cause	Investigation method	Countermeasures
SI unit COM LED is OFF.	Communication failure of the branch port	Check the branch cable connections and check for broken wires.	Tighten the branch cable connection. (if there is a broken wire, replace the cable)
		Check the wiring length of the branch cable and check that the recommended cable is used.	Review wiring Total length 20 m or less per branch
		Check that there is no high voltage cable or equipment that generates noise around the branch cable.	Separate the branch cable away from noise sources.

Fault No. 12

Fault	Possible cause	Investigation method	Countermeasures
Solenoid valves not operating correctly. Solenoid valve LED is OFF.	Defective connection between the SI unit and solenoid valve manifold.	Check for any loose screws at the connection between the SI unit and the valve manifold.	Same as Investigation method.
	Polarity of the solenoid valve and the SI unit output are not compatible.	Check that the solenoid valve polarity specification and output polarity of the SI unit are compatible.	The solenoid valve polarity specification and output polarity of the SI unit are compatible.
	Solenoid valve failure	Refer to the troubleshooting of the solenoid valve.	Same as Investigation method.

Fault No. 13

Fault	Possible cause	Investigation method	Countermeasures
Solenoid valves not operating correctly. Solenoid valve LED is ON.	Solenoid valve failure	Refer to the troubleshooting of the solenoid valve.	Same as Investigation method.

Fault No. 14

Fault	Possible cause	Investigation method	Countermeasures
Input unit PWR LED is OFF.	Power supply for input and control: 24 VDC $\pm$ 10%	Check the branch cable connections and check for broken wires.	Tighten the branch cable connection. (if there is a broken wire, replace the cable)

Fault No. 15

Fault	Possible cause	Investigation method	Countermeasures
Input unit ERR LED is ON	Over current power supply for input and control	Check the total current consumption of the input devices such as the sensor used.	Ensure that the total current consumption is within the specified range of the input unit.
		Check the input devices used, and check the wiring to the input devices. Refer to the input device operation manual troubleshooting section, or contact the input device manufacturer.	Resolve the short-circuit or over current.
	Power supply short-circuit of the input devices used.	Check the troubleshooting of input equipment Or, confirm with the manufacturer of the input equipment.	Same as Investigation method.

Fault No. 16

Fault	Possible cause	Investigation method	Countermeasures
Corresponding GW unit COM *LED is OFF.	Communication failure of the branch port	Check the branch cable connections and check for broken wires.	Tighten the branch cable connection. (if there is a broken wire, replace the cable)
		Check the wiring length of the branch cable and check that the recommended cable is used.	Revise the wiring length: Total length 20 m or less per branch Exclusive cables: EX500-AC□□□-S□P□
		Check that there is no high voltage cable or equipment that generates noise around the branch cable.	Separate the branch cable away from noise sources.

Fault No. 17

Fault	Possible cause	Investigation method	Countermeasures
Input unit display LED does not turn ON.	Polarity of the input unit and input device including sensor are not compatible.	Check that the polarity of the input unit and the input device are compatible.	Use an input device polarity compatible with the polarity of the input unit.
	Defective connection between the input unit and input device.	Check the input device connection and wiring (pin layout) and check for broken wires.	Tighten the cable connection. (Replace the cable if it is broken.)
	Malfunction of input unit	-	Rectify the wiring of the input device cable. Contact your sales representative.

Fault No. 18

Fault	Possible cause	Investigation method	Countermeasures
Input unit display LED and the input data do not match.	Communication failure of the branch port	Check the wiring length of the branch cable and check that the recommended cable is used.	Review wiring Total length 20 m or less per branch
		Check that there is no high voltage cable or equipment that generates noise around the branch cable.	Separate the branch cable away from noise sources.
	Malfunction of input unit	-	Contact your sales representative.

# Accessories

## (1) Ethernet communication connector cable

How to Order: EX9-AC 020 EN-PSRJ

Cable length (L)		Connector specification M12 plug connector with RJ45 connector
010	1 m	
020	2 m	
030	3 m	
050	5 m	
100	10 m	

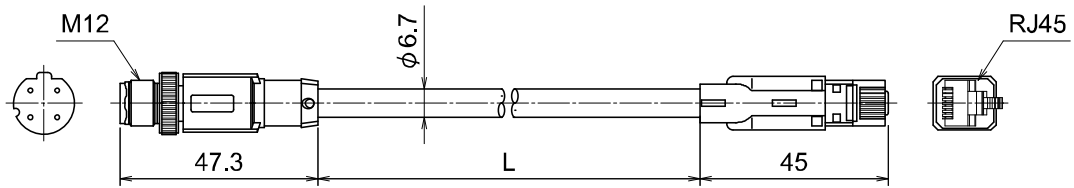

With M12 socket connector  
EX9-AC  EN-PSRJ

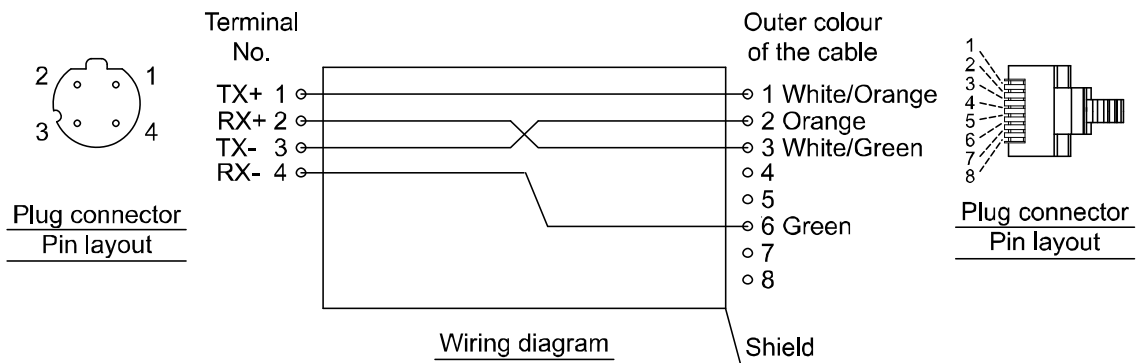

Item	Specifications
Cable O.D.	φ6.7 mm
Min. bending radius	34 mm

## How to Order: PCA-1446566

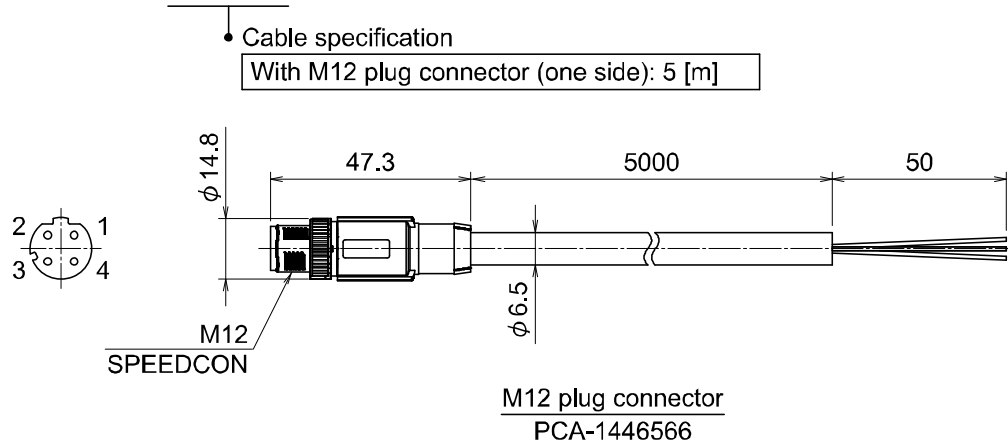

Item	Specifications
Cable O.D.	φ6.5 mm
Nominal cross section	AWG22
Wire diameter (Including insulator)	1.5 mm
Min. bending radius	45.5 mm

Pin No.	Cable color: Signal
1	Yellow: TX+
2	White: RX+
3	Orange: TX-
4	Blue: RX-

## (2) Assembly type communication connector for Ethernet

### How to Order: PCA-1446553

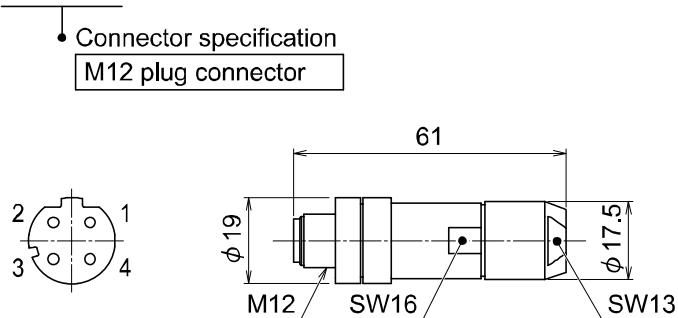

### Applicable cable

Item	Specifications
Cable O.D.	φ4.0 to 8.0 mm
Electric wire cross section (Twist line)	AWG26 to 22

(3) Cable with 7/8 inch connector for power supply.

How to Order: PCA-1415999

• Cable specification

1415999	Straight: 2 m
1415996	Straight: 6 m
1416000	Angle: 2 m
1415997	Angle: 6 m

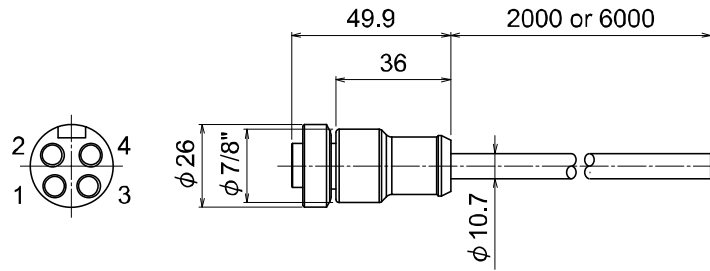

Straight connector type

2 m: PCA-1415999

6 m: PCA-1415996

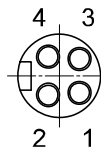
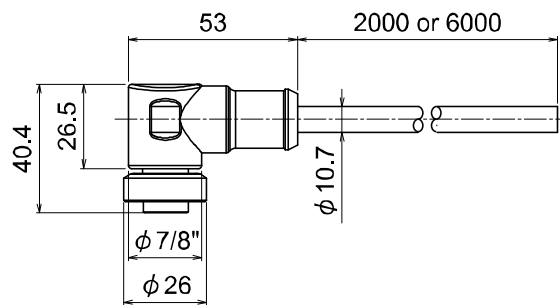

Angled connector type

2 m: PCA-1416000

6 m: PCA-1415997

Item	Specifications
Cable O.D.	10.7 mm
Nominal cross section	AWG16
Min. bending radius	94 mm (when fixed)

Pin No.	Cable color: Signal
1	Red: 24 VDC (For solenoid valves)
2	Green: 24 VDC (For input and control)
3	White: 0 V (For input and control)
4	Black: 0 V (Solenoid valve)



(4) Branch cable with M12 connector

How to Order: EX500-AC 030 - SSPS

Cable length (L)	
003	0.3 m
005	0.5 m
010	1 m
030	3 m
050	5 m
100	10 m

Connector specification	
SSPS	Socket side: Straight, Plug side: Straight
SAPA	Socket side: Angled, Plug side: Angled

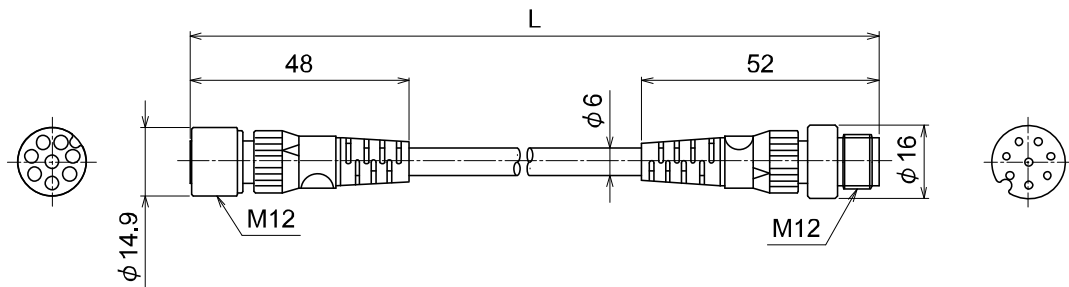

Straight connector type  
EX500-AC□-SSPS

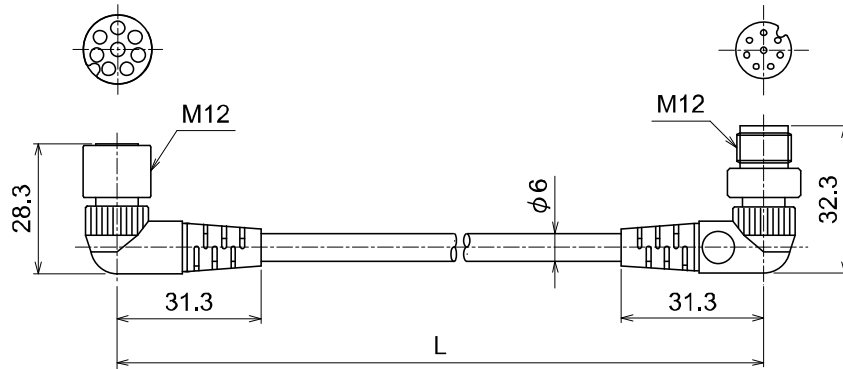

Angled connector type  
EX500-AC□-SAPA

L = 300, 500, 1000, 3000, 5000, 10000 (mm)

Item	Specifications
Cable O.D.	ø6 mm
Min. bending radius	40 mm (When fixed)

(5) Y branch connector

Connector to provide a separate power supply to SI unit valve.

How to Order: EX500-ACY01-S

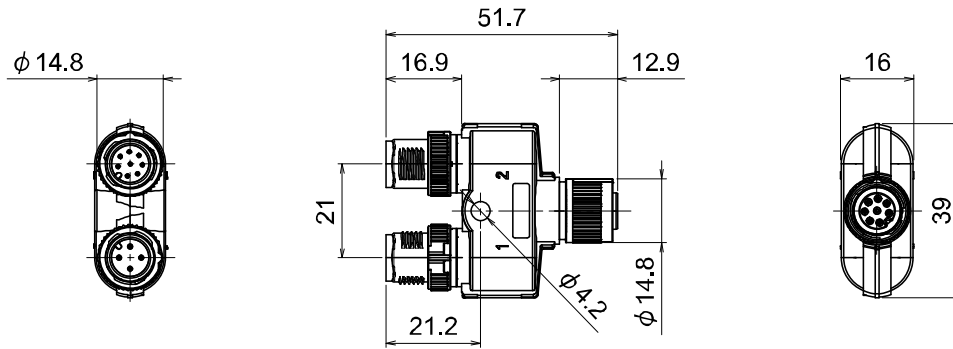

(6) DIN rail bracket (2 pcs.)

Bracket for mounting the input unit to DIN rail.

How to Order: EX500-ZMA1

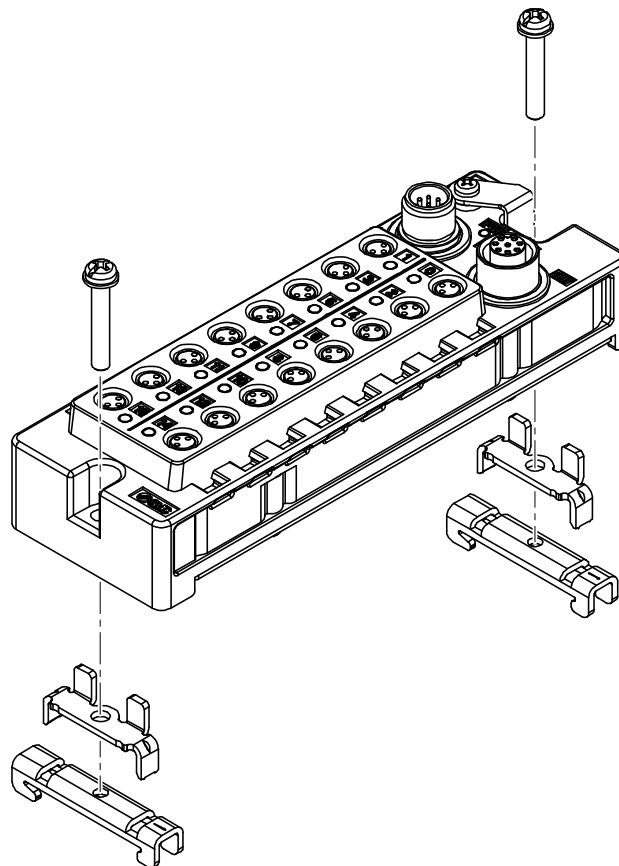

(7) Marker (1 sheet, 88 pcs.)

The signal name of the input device and unit address can be written on the marker, and can be installed to each unit.

How to Order: EX600-ZT1

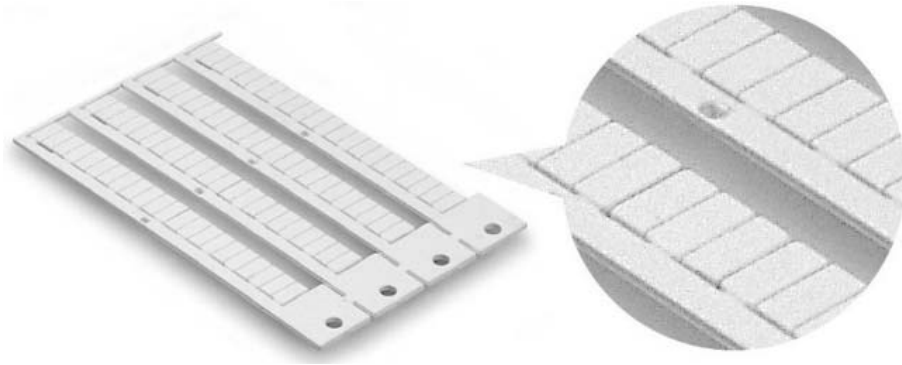

(8) Seal cap

Mount the seal cap in the unused ports of the GW unit and input unit.  
IP65/67 is satisfied by using the seal cap properly.  
(The seal cap is provided with each product.)

How to Order: EX9-AW

• Connector specification

ES	M8, connector (for socket): 10 pcs.
TS	M12, connector (for socket): 10 pcs.

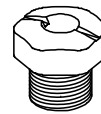

**NOTE**

Tighten the seal caps to the tightening torque specified.  
(For M8: 0.05 Nm, M12: 0.1 Nm)

Revision history
------------------

## SMC Corporation

4-14-1, Sotokanda, Chiyoda-ku, Tokyo 101-0021 JAPAN

Tel: +81 3 5207 8249 Fax: +81 3 5298 5362

URL <http://www.smcworld.com>

---

NOTE: Specifications are subject to change without prior notice and any obligation on the part of the manufacturer.

EtherNet/IP™ is a trademark of ODVA.

© 2015 SMC Corporation All Rights Reserved

