



Operation Manual

PRODUCT NAME

Vacuum regulator

MODEL/ Series

IRV10

IRV10A

IRV20

IRV20A

SMC Corporation

Table of Contents

Safety Instructions	2~3
Introduction	4
1. Specifications	4
2. Construction and Operating Principle	5
3. How to Order	6
4. Specific Product Precautions	7~11
5. Warranty	12
6. Disassembling Drawing	13~16
7. Spare Parts Kit	17~18
8. Assembly Drawing	19~22

Safety Instructions

Be sure to read and understand this operation manual before handling.

Keep this operation manual to refer anytime necessary and make sure to deliver this manual to the end user.

These safety instructions are intended to prevent hazardous and/or equipment damage.

These instructions indicate the level of potential hazard by labeling "Caution", "Warning" or "Danger". To ensure safety, be sure to observe ISO4414(Note1), JIS B 8370(Note2) and other safety practices.

Caution

Operator error could result in injury or equipment damage.

Warning

Operator error could result in serious injury or loss of life.

Danger

In extreme conditions, there is a possibility of serious injury or loss of life.

(Note 1) I S O 4 4 1 4 Pneumatic fluid power-Recommendations for the application of equipment to transmission and control systems.

(Note 2) J I S B 8 3 7 0 General Rule for Pneumatic Systems



Warning

- ① The compatibility of pneumatic equipment is the responsibility of the person who designs the pneumatic system of decides its specifications.

Since the products specified here are used in various operating conditions, their compatibility with the specific pneumatic system must be based on specifications or after analysis and/or tests to meet your specific requirements.

- ② Only trained personnel should operate pneumatically operated machinery and equipment.

Compressed air can be dangerous if an operator is unfamiliar with it. Assembly, handling or pneumatic systems should be performed by trained and experienced operators.

- ③ Do not service machinery/equipment or attempt to remove components until safety is confirmed.

Ⓐ Inspection and maintenance of machinery/equipment should only be performed after confirmation of safe locked-out control positions.

Ⓑ When equipment is to be removed, confirm the safety process as mentioned above. Cut the supply pressure for the equipment and exhaust all residual compressed air or vacuum pressure (negative pressure) in the system.

Ⓒ Before machinery/equipment is re-started, take measures to prevent quick extensions of the cylinder piston rod etc. (Bleed air into the system gradually to create back-pressure.)

- ④ Contact SMC if the product is to be used in any of the following conditions,

Ⓐ Conditions and environments beyond the given specifications, or if product is used outdoors.

Ⓑ Installation on equipment in conjunction with atomic energy, railway, air navigation, vehicles, medical equipment, food and beverage, recreation equipment, emergency stop circuits, press applications, or safety equipment,

Ⓒ An application which has the possibility of having negative effects on people, property, or animals, requiring special safety analysis,

Introduction

IRV10,10A,20,20A vacuum regulator is an apparatus to adjust vacuum pressure (negative pressure) Arbitrarily by connecting vacuum pump to the port on the VAC. side.

1 .Specifications

Model		IRV10※	IRV20※
Fluid		Air	
Set pressure		-100 to -1.3kPa (Note 1)	
Handle resolution		within 0.13kPa (Note 2)	
Air suction rate		within 0.6 ℓ/min(ANR)	
Operating temperature		5~60°C	
Vacuum side port size		φ 6、 φ 8	φ 6、 φ 8、 φ 10
Set side port size		φ 1/4"、 φ 5/16"	φ 1/4"、 φ 5/16"、 φ 3/8"
Weight (No accessories)	Renewal type	135g(IRV10-C08)	250g(IRV20-C10)
	One-side piping type	125g(IRV10A-C08)	250g(IRV20A-C10)

(Note 1) This varies with pressure on vacuum pump side.

(Note 2) This value varies with conditions and does not guarantee the practical performance.

2 .Construction and Operating Principle

By turning handle①clockwise, force of set spring②pushes down diaphragm③and main valve④ so that VAC. Pressure side and SET. Pressure side are connected, which increases vacuum on SET. Pressure side (become closer to absolute vacuum).

Vacuum pressure on SET. Pressure side passes air pass, goes to vacuum chamber⑥and acts on the top of diaphragm③. This pressure opposes compression force of set spring② and becomes SET. Pressure.

When vacuum SET. Pressure becomes higher than the set value (closer to absolute vacuum), balance of set spring② and SET. Pressure in vacuum chamber⑥ is lost. Because of this, diaphragm③ is pushed up so that main valve④ closes and atmosphere suction valve⑤ opens. Atmosphere flows in SET. Pressure and becomes SET. Pressure when compression force of set Spring② balances with SET. Pressure.

When vacuum of SET. Pressure becomes lower than the set value (closer to atmospheric pressure), balance of set spring② and SET. Pressure in vacuum chamber⑥ is lost, and diaphragm ③ is pushed down. Atmosphere suction valve⑤ closes and main valve④ opens, and air is sucked to VAC. Pressure side. It becomes SET. Pressure when compression force of set spring② balances with SET. Pressure.

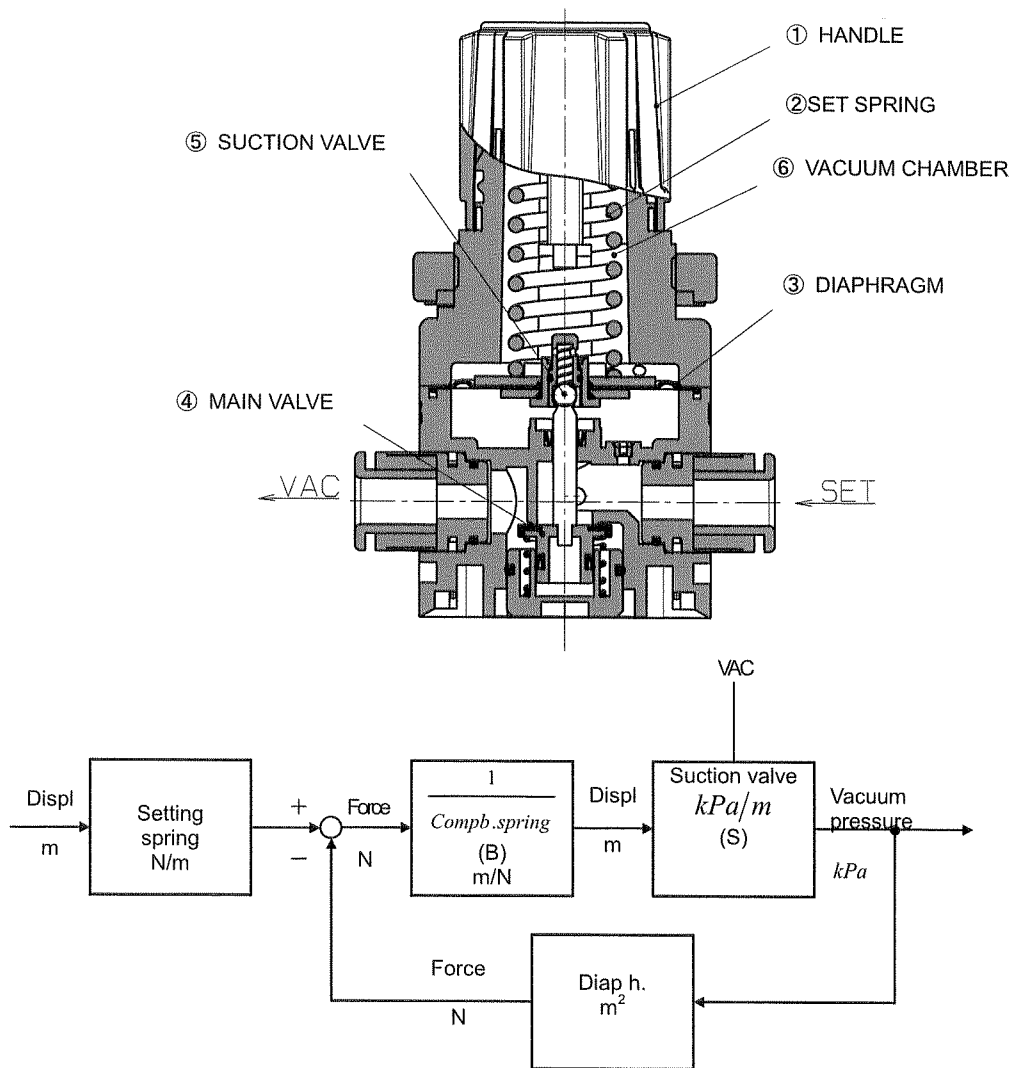

Block Diagram

3 .How to Order

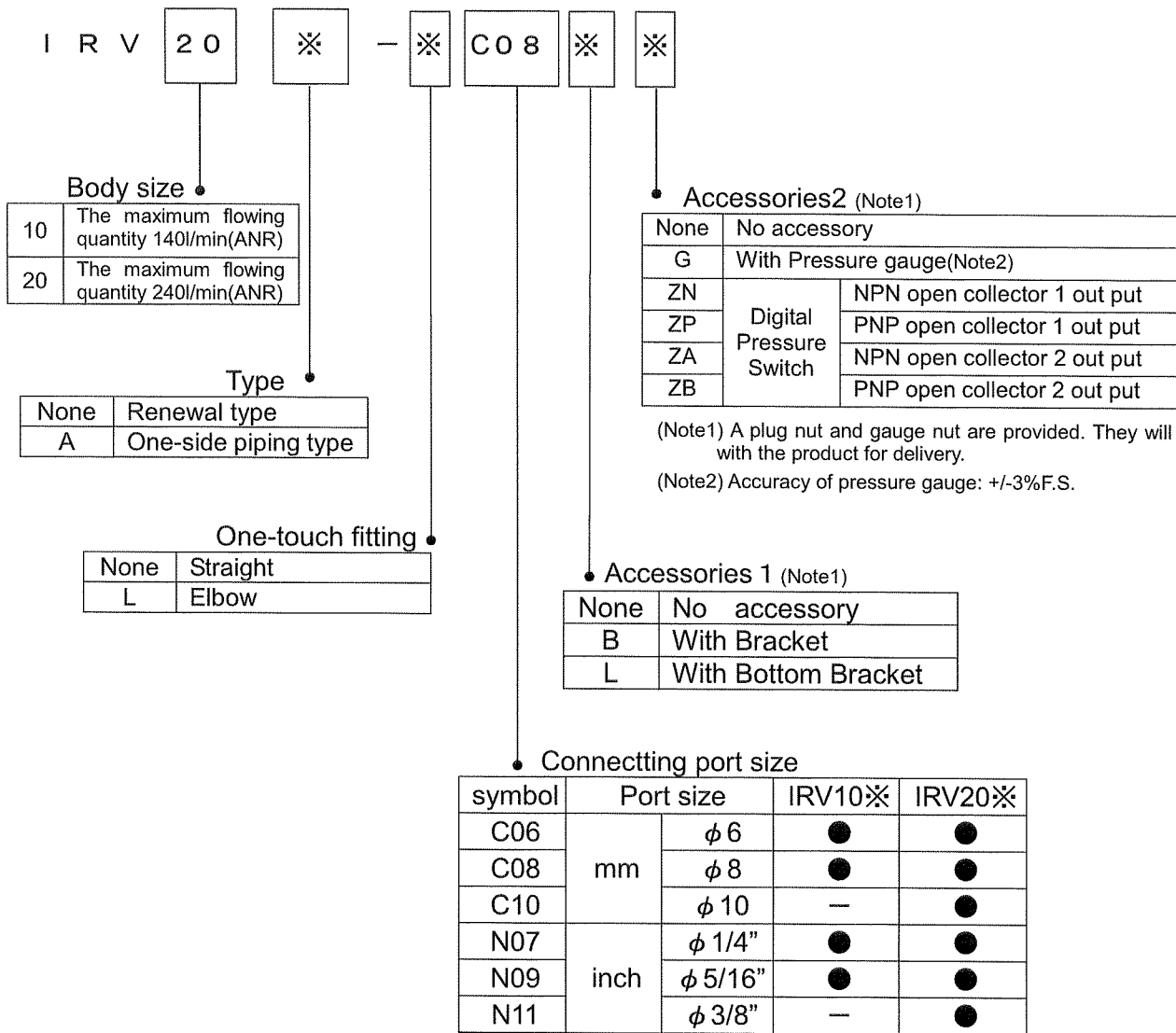

4 .Specific Product Precautions



Warning

Handling

- (1) If a possible danger of system is expected when vacuum pressure is Decreased by service interruption and/or vacuum pump trouble,provide the system with a safety circuit to avoid such a danger.
- (2) If a possible danger of system is expected when vacuum regulator fails, provide the system with a safty circuit to avoid such a danger.



Caution

Handling

- (1) Reduce the set pressure to zero(atomospheric pressure) for removing the plug when additionally mount the pressure gauge and pressure switch.

1.For customers purchasing regulator with a pressure gauge or pressure switch

1-1 Accessories

- Pressure gauge (GZ43,GZ33)or pressure switch (ZSE30A)-----1 piece
- Gauge nut (with O-ring)-----1 piece

Note) The gauge nut is mounted on the pressure gauge or pressure switch.

- Plug nut (with O-ring)-----1 piece
- Clip-----1 piece

Note) For the summarized piping specification, only 1 clip is provided ,and no plug nut is provided.

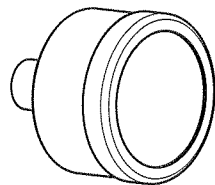

Pressure gauge

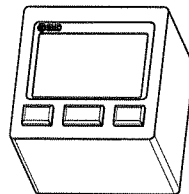

Pressure switch

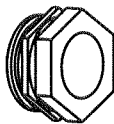

Gauge nut

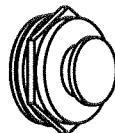

Plug nut



Clip

1-2 Mounting of pressure gauge or pressure switch

1) Confirm the VAC side and SET side of the product, and insert the pressure gauge or pressure switch completely (until flush with the product surface) into the preferred hexagon gauge port.

Insert the clip to the left side of the product completely as shown in the figure.

2) After insertion, check to ensure the pressure gauge does not come off.

This is the end of the mounting procedure for the summarized piping specification.

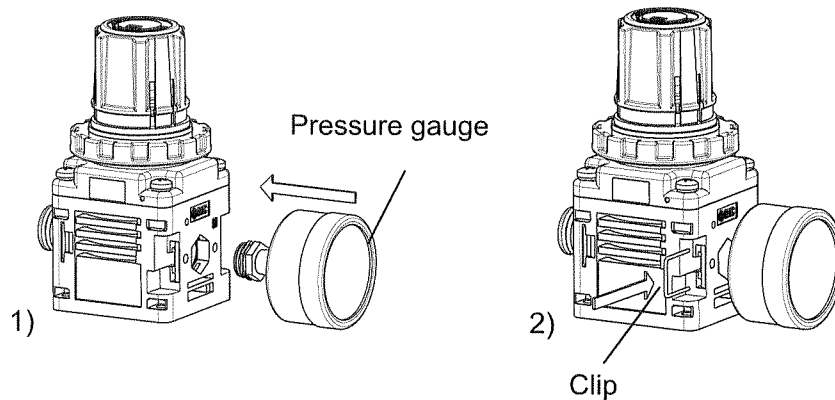

3) Insert the plug nut into the opposite gauge port completely.

4) Insert the clip into the left side of the product completely as with 2).

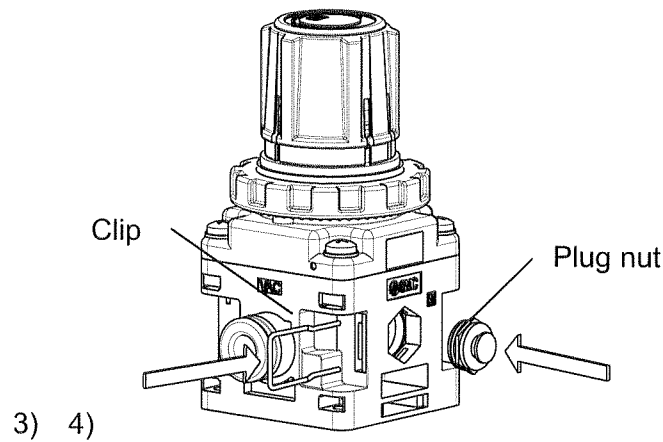

Note) When the pressure gauge or pressure switch is removed, be sure to remove the clip straight.

The body is made of resin, so never apply torque.

(2) Do not remove the biss on the body with negative pressure applied.

(3) Reduce the set pressure to zero(atmospheric pressure) and shut off the vacuum pump pressure completely for removing the guide for inspection.

(4) One touch fitting is cassette type for easy replacement. One-touch fitting is set by clip inserted as drawing below. To replace the fitting, remove the clip with flat blade driver. Then, insert one-touch fitting until it contact to the end, and insert the clip to its original position.

- Note1) Before replacement, ensure that VAC.SET pressure is not applied and exhaust inside pressure completely. Operation with pressure applied is dangerous.
- Note2) To pull out the clip, pull it out slowly supporting with hand. The clip may pop out and dangerous if pulling the clip with force.
- Note3) After ensuring the replacement part is inserted to the end, insert the clip to the end. If the clip is not inserted completely, it will come off.
- Note4) To insert elbow type one-touch fitting, hold the fitting with hand during inserting the tube. Inserting the tube without holding the body applies excess force to blocks and one-touch fitting and it leads to cause air leakage and damage.

How to pull out the clip

Set the driver tip to the slope of the place where the clip inserted, lift the clip by moving the driver slowly.

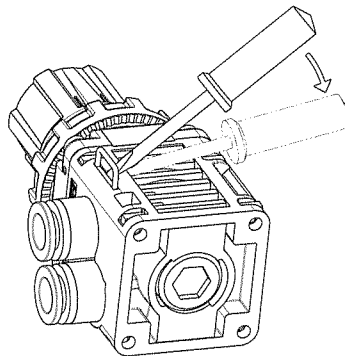

Mounting of fitting assembly

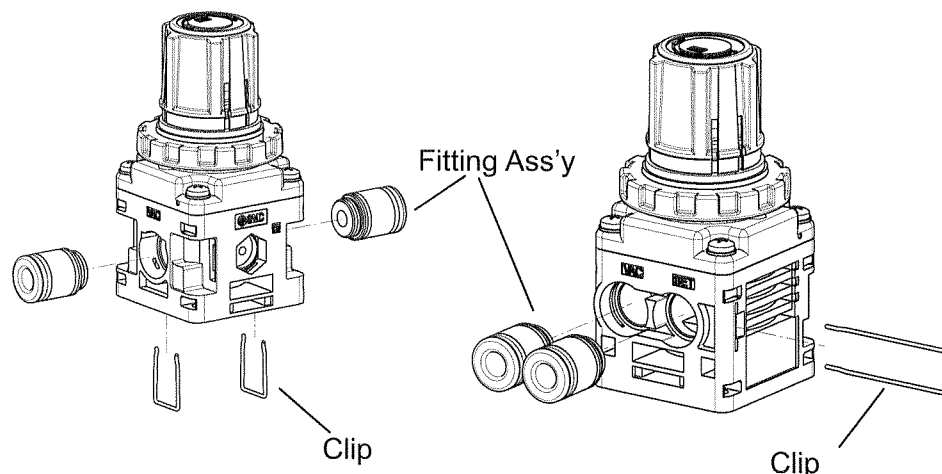

Warning

Handling

(1) Keep the specified tightening torque for mounting

Excessive torque can damage the mounting screws and product body.
And insufficient torque can cause the threaded parts to loosen.

Cross recessed round head screw for mounting the bottom bracket

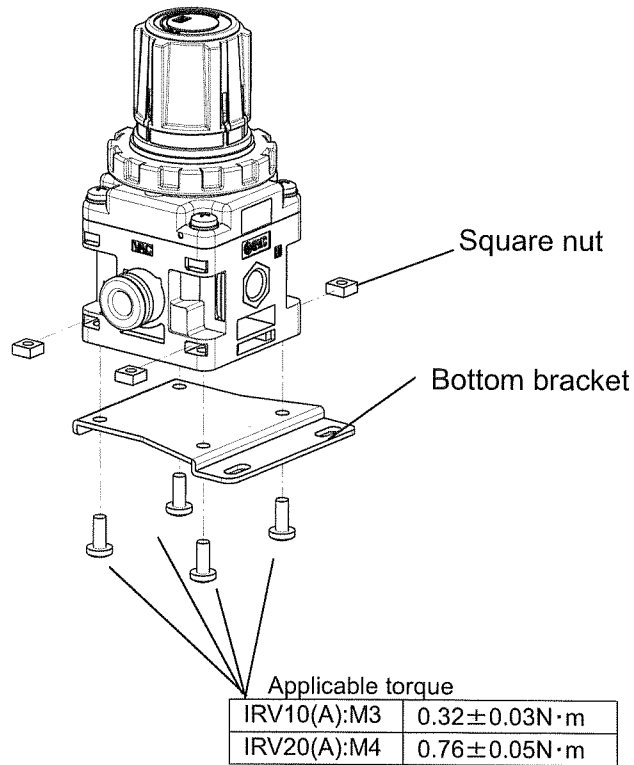

Caution

Environment

- (1) Do not use the product in an environment where the product is directly exposed to corrosive gases, chemicals, salt water or steam.
- (2) Do not mount the product in a location where it is subject to strong vibrations and/or shocks.
- (3) Use this vacuum regulator in a location free from dirt since this product sucks atmosphere all the time.
- (4) When the product is directly exposed to sunlight, provide a protective cover.
- (5) When heat source is around the product, shut off radiant heat.

Caution

Vacuum Source

- (1) This vacuum regulator is not designed to adjust pressure of vacuum pump.
- (2) Note that ejector should not be used as "vacuum source" since its flow rate is less than this vacuum regulator.

⚠ Caution

Air

- (1) Contact SMC when using the product in applications other than Compressed air.
- (2) Do not use air containing chemicals, synthetic oils with organic solvents, Salinity and corrosive gases.

⚠ Caution

Operation

- (1) Connect vacuum pump to the port indicated by "VAC"(shown in upper Right of the port).
- (2) Pressure changes "atmospheric pressure→vacuum pressure" by turning the handle clockwse and "vacuum pressure→atmospheric pressure" by turning the handle counterclockwise.
- (3) Never touch to exhaust hole (Inlet for atmosphere)on the body during adjusting pressure.
- (4) To lock the handle after pressure setting, push the handle until orange Mark below is hidden and it clicks. To unlock the handle, pull the handle until the orange make is seen and it clicks.
- (5) Do not apply positive pressure to this vacuum regulator since this is for Negative pressure use only. If positive pressure is applied, this vacuum regulator will not be broken. However, main valve inside pressure adjusting valve becomes "open" and positive pressure will be introduced to vacuum pump, and vacuum pump may be failed.
- (6) When vacuum pump capacity is relatively small or piping ID is small, large fluctuation of set pressure (variation range in pressure when flowing from zero) may be the result. In this case, change the vacuum pump or piping diameter. If the vacuum pump may not be replaced, add a tank (capacity of the tank depends on the operating conditions) on VAC side.
- (7) Note that pressure response time after valve (solenoid valve) opening/ closing is affected by internal volume of the setting side (including piping volume). In addition, capacity of vacuum pump affects the response time.
- (8) If pressure gauge is used in the direction as Figure 1, it may cause displacement from zero point. So, be sure to use pressure gauge in the Direction as Figure 2

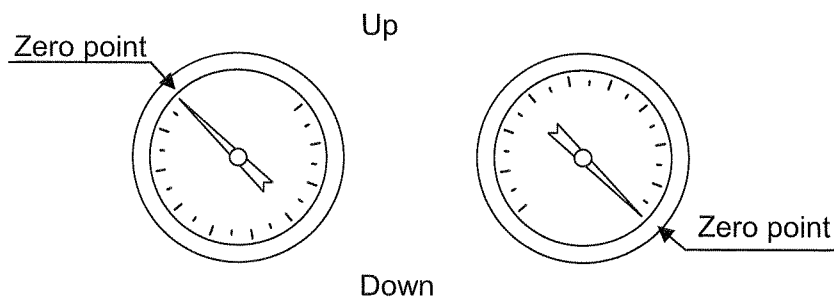

5.Warranty

1. Period: 1.5 year after delivery to the customer's specified location or one year after starting operation, whichever comes sooner.
2. Scope: If a failure occurs within the warranty period which is deemed to be SMC's responsibility, we will provide a replacement product as limited warranty. Any loss or damage incurred by the failure is not covered by the warranty."
3. Contents:
 - a. We guarantee that the product will operate normally if it is installed under maintenance and control in accordance with the Operation Manual, and operated under the conditions specified in the catalog or contracted separately.
 - b. We guarantee that the product does not have any defects in components, materials or assembly.
 - c. We guarantee that the product complies with the outline dimensions provided.
 - d. The following situations are out of scope of this warranty.
 - 1) The product was incorrectly installed or connected with other equipment.
 - 2) The product was under insufficient maintenance and control or incorrectly handled.
 - 3) The product was operated outside of the specifications.
 - 4) The product was modified or altered in construction.
 - 5) The failure was a secondary failure of the product caused by the failure of equipment connected to the product.
 - 6) The failure was caused by a natural disaster such as an earthquake, typhoon, or flood, or by an accident or fire.
4. If there is any doubt about anything specified in "Scope" and "Content", it shall be resolved by agreement between the customer and SMC.

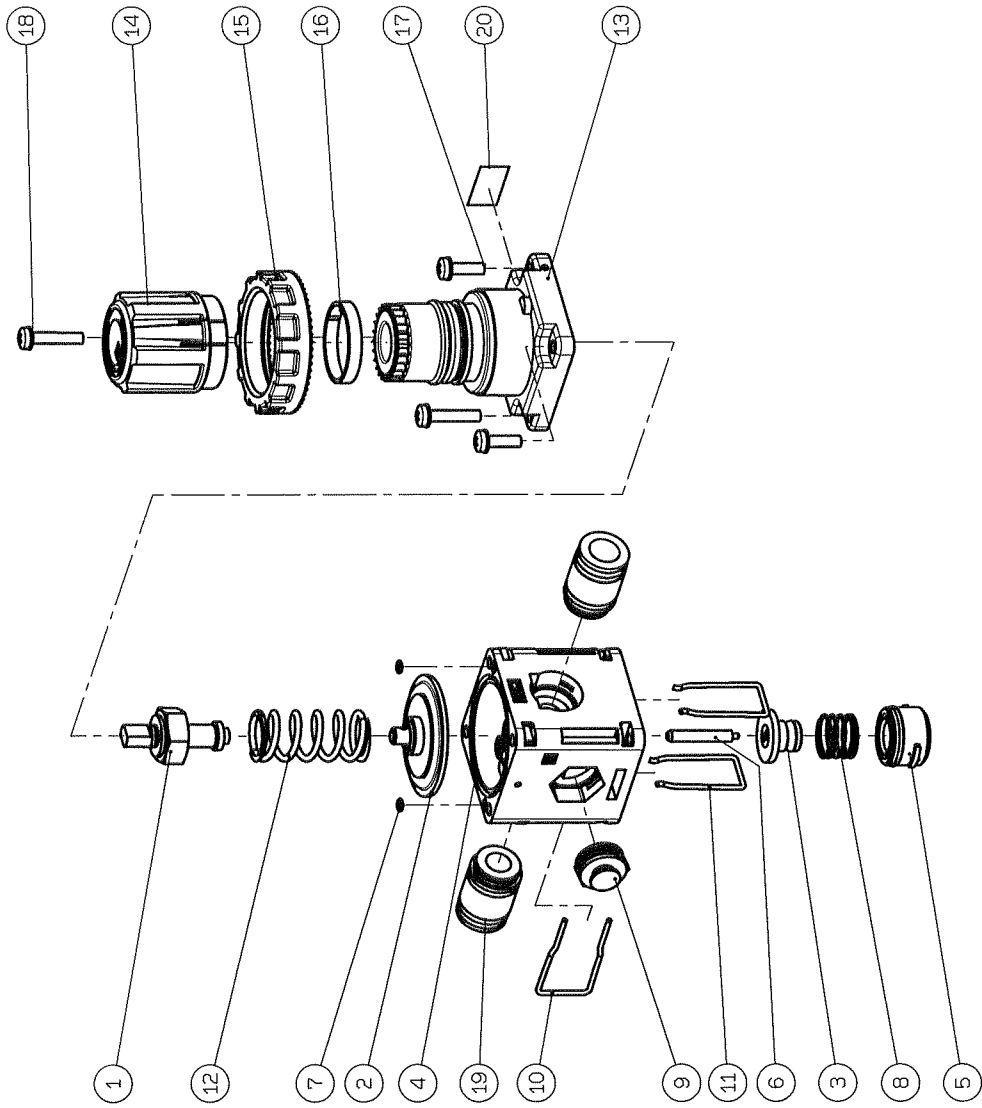

ITEM	PART · NO	PART · NAME	MATERIAL	QTY	REMARKS
20	VVQ1000-51A-*	Name plate	RESIN	1	
19	One-touch fitting			2	
18	Machine screw	Steel		2	M3X15
17	Machine screw	Steel		2	M3X10
16	Set nut	RESIN		1	
15	Handle	RESIN		1	
14	Bonnet assembly	Steel		1	
13	Adjusting spring	Steel		1	
12	Clip for fitting	stainless		2	
11	Clip for nut	stainless		1	
10	Plug nut	Brass		2	
9	Valve spring	stainless		1	
8	O-ring	NBR		2	Φ1.7X0.85
7	KA01749	Stem	Brass	1	
6	Valve guide assembly			1	
5	Body assembly			1	with orifice
4	Valve assembly			1	
3	P601010-3	Diaphragm assembly		1	
2	P601010-2	Diaphragm pressure screw		1	
1		ASSEMBLY		1	

REVISION	DESCRIPTION	DATE	PREPARED	REV. NO	SCALE	DWG. NAME	THIRD ANGLE
1					1:1	VACUUM REGULATOR Resolution Assembling Drawing	

TOLERANCES UNLESS OTHERWISE SPECIFIED	DRAWN	DATE	DESIGNED	DATE	CHECKED	DATE	APPROVED	DATE
0.5-0.25	1	0.1	0.2	0.1	0.3	0.3	0.8	1.2
3-0.25	0.2	0.1	0.2	0.1	0.2	0.3	0.8	1.2
6-0.25	0.1	0.1	0.2	0.1	0.2	0.3	0.8	1.2
30-0.25	0.1	0.1	0.2	0.1	0.2	0.3	0.8	1.2
120-0.25	0.1	0.1	0.2	0.1	0.2	0.3	0.8	1.2
400-0.25	0.1	0.1	0.2	0.1	0.2	0.3	0.8	1.2

FINISH	PAINT	POSSING	INTERNAL	EXTERNAL

IRV10	MODEL	REV. NO
1		

DWG. NO	DWG. TITLE	REVISION
TA IRV10	Vacuum Regulator Resolution Assembling Drawing	

FIG. NO.

TA IRV10A

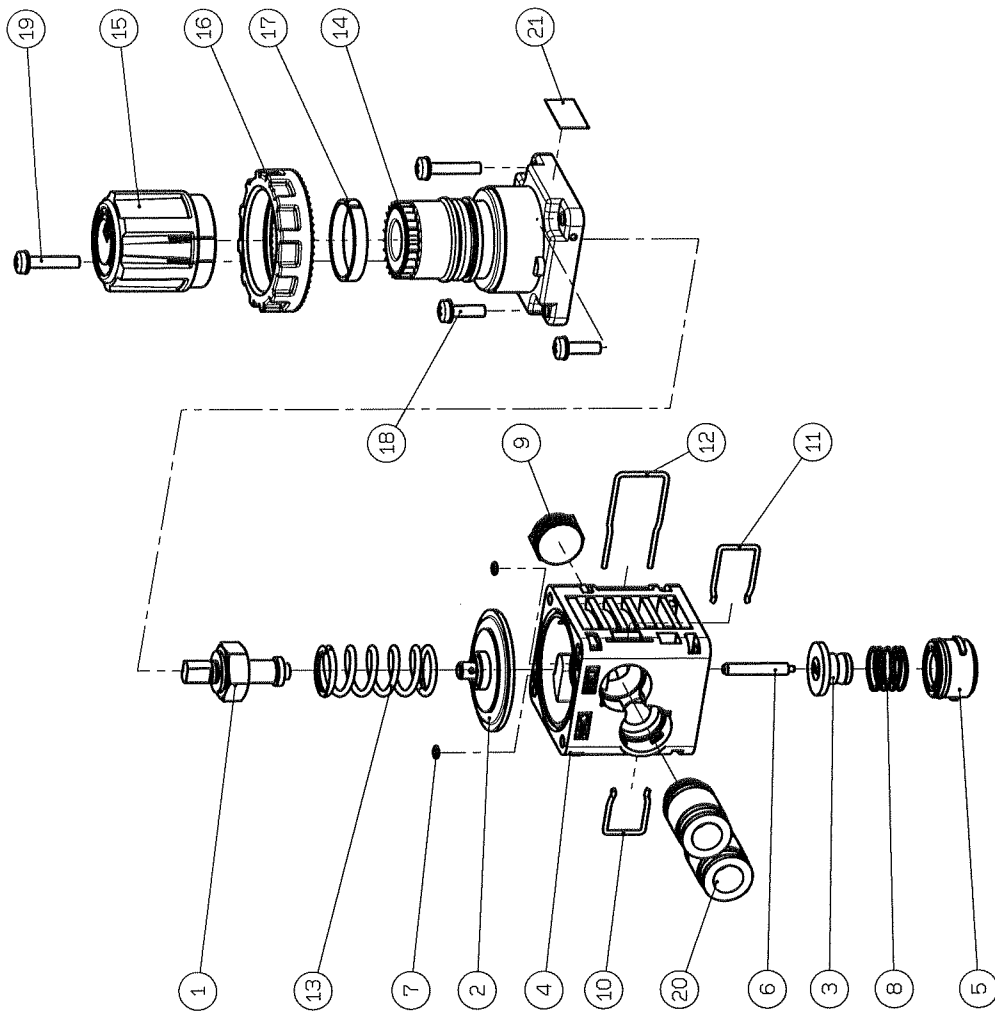

ITEM	PART · NO	PART · NAME	MATERIAL	QTY	REMARKS
21	VVQ1000-51A-※	Name plate	Resin	1	
20		One-touch fitting	Steel	2	
19		Machine screw	Steel	2	M3x15
18		Machine screw	Steel	2	M3x10
17		Set ring	Resin	1	
16		Set nut	Resin	1	
15		Handle	Resin	1	
14		Bonnet assembly	Steel	1	
13		Adjusting spring	Steel	1	
12		Clip for nut	stainless	1	
11		Clip for fitting	stainless	1	
10		Clip for fitting	stainless	1	
9		Plug nut	Brass	1	
8		valve spring	stainless	1	
7	KA01749	O-ring	NER	2	φ1.7x0.85
6		Stem	Brass	1	
5		valve guide assembly		1	
4		Body assembly		1	with orifice
3	P601010-3	Valve assembly		1	
2	P601010-2	Diaphragm assembly		1	
1		ADJUSTING pressure screw assembly		1	

REVISION	DESCRIPTION	DATE	PREPARED	REV. NO	SCALE	DRAWN	DATE	DESIGNED	CHECKED	APPROVED	DATE
					1:1						

TOLERANCES AS B SHOWN	FINISH	IRV10 MODEL
RANGE(mm)	PAINT	1
0.5-0.25		
3-0.25		
6-0.25		
30-0.25		
120-0.400		
300-0.51000		
600-0.63500		

THIRD ANGLE	IRV10 MODEL
1	1

DWG NO	TA IRV10A
REVISION	
DWG NAME	Vacuum Regulator Resolution Assembling Drawing

DWG NO. IAD50250400 SMC Corporation

FINISH: 表面処理 / PAINT: 塗料 / PACKING: 包装方法
MATERIAL: 材質 / MATERIAL SIZE: 材料寸法

7. LIST OF SPARES

Document No.

DIK-45700-SL003

Page 1/1

TITLE Series IRV10※ Repairing parts kit

MODEL No. IRV10※

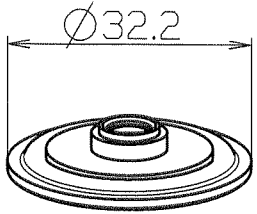
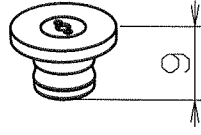
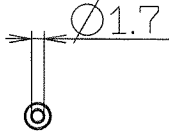
No.	NAME	SKETCH	MATERIAL	SUPPLY QUANTITY		DRAWING		REMARKS
				WORKING	SPARE	PART No.	ITEM No	
1	Diaphragm Ass'y		NBR	1		P601010-2		
2	Valve Ass'y		NBR	1		P601010-3		
3	"O"ring		NBR	2		φ 1.7× 0.85		

TITLE Series IRV20※ Repairing parts kit
 MODEL No. IRV20※

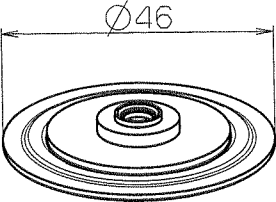
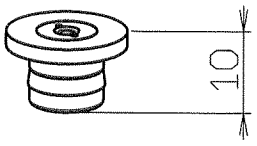
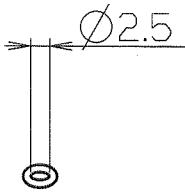
No.	NAME	SKETCH	MATERIAL	SUPPLY QUANTITY		DRAWING		REMARKS
				WORKING	SPARE	PART No.	ITEM No	
1	Diaphragm Ass'y		NBR	1		P601020-2		
2	Valve Ass'y		NBR	1		P601020-3		
3	"O"ring		NBR	2		φ 2.5×1		

Specification
 Setting pressure -100~-1.3kPa
 Operating temperature 5~60°C
 VAC side port size $\phi 6$, $\phi 1/4$, $\phi 8$, $\phi 5/16$
 SET side port size $\phi 6$, $\phi 1/4$, $\phi 8$, $\phi 5/16$
 Port size for pressure gauge Rc1/8 (pressure gauge with pressure switch attached only one)
 weight (without accessory) 125g (RV10A-C05)

One-touch fitting dimension

One-touch fitting size	VAC/SET			
	Straight	Elbow	Elbow	Elbow
$\phi 6$, $\phi 1/4$	R	S	T	U
$\phi 8$, $\phi 5/16$	10	19	26	7.5
	12	20	28	10.5
				14

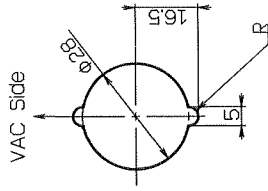
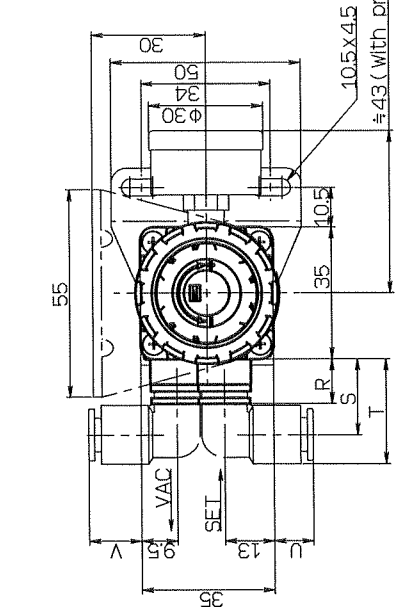

Model identification numbering

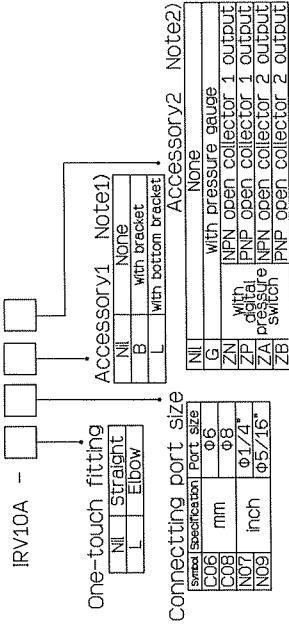

Note1) Note2)
 Accessories1,2 are shipped together

Panel cut
 Panel board thickness max.3

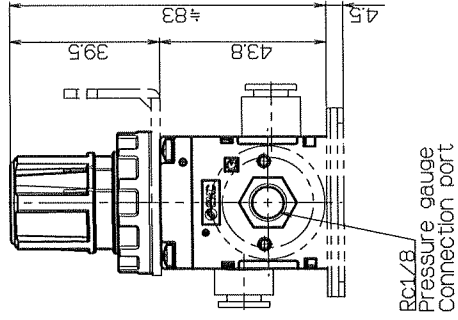
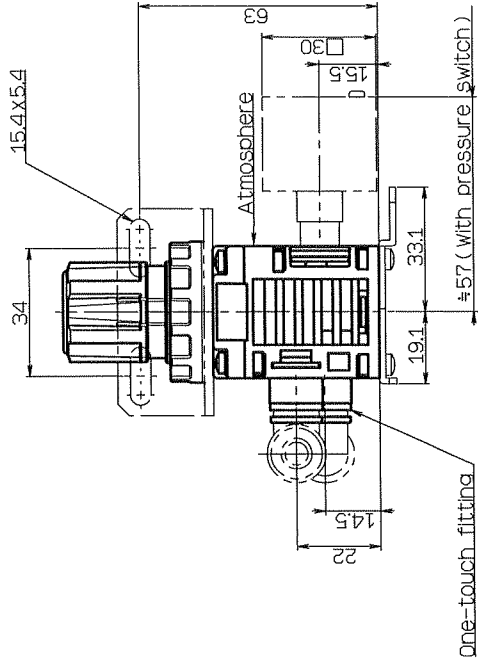

Mounting direction of pressure gauge
 if pressure gauge is used in the direction as Figure 1, it may cause displacement from zero point. So be sure to use pressure gauge in the direction as Figure 2.

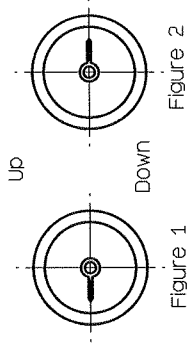

ITEM	PART. NO.	PART. NAME	MATERIAL (QTY)	REMARKS
		FINISH		
		PAINT	URBAN WHITE	
		ACOME		
		INTERNAL		
		EXTERNAL		
		SCALE	1:1	
		DWG. NAME	vacuum Regulator	
		DWG. NO.	① IRV10A - * * * * *	
		REVISION		
		THIRD ANGLE		
		MODEL		

REV. NO.	DATE	PREPARED	REV. NO.	DATE	APPROVED
1	02/01/02		1	02/01/02	
2	02/01/02		2	02/01/02	
3	02/01/02		3	02/01/02	
4	02/01/02		4	02/01/02	
5	02/01/02		5	02/01/02	
6	02/01/02		6	02/01/02	
7	02/01/02		7	02/01/02	
8	02/01/02		8	02/01/02	
9	02/01/02		9	02/01/02	
10	02/01/02		10	02/01/02	
11	02/01/02		11	02/01/02	
12	02/01/02		12	02/01/02	
13	02/01/02		13	02/01/02	
14	02/01/02		14	02/01/02	

Revision history

SMC Corporation

URL <http://www.smcworld.com>

4-14-1 Sotokanda, Chiyoda-ku, Tokyo 101-0021, Japan

Tel: 03-5207-8271 Fax: 03-5298-5361

2007 SMC Corporation All Rights Reserved

