



Operation Manual

PRODUCT NAME

Solid State Auto Switch

MODEL / Series / Product Number

*D-M9***

SMC Corporation



Contents

Safety Instructions	2
Model Indication and How to Order	8
Summary of Product parts	9
Definition and terminology	10
Mounting and Installation	11
Installation	11
Maintenance	12
Troubleshooting	13
Specification	17
Specifications	17
Dimensions	18

Safety Instructions

These safety instructions are intended to prevent hazardous situations and/or equipment damage. These instructions indicate the level of potential hazard with the labels of "Caution", "Warning" or "Danger". They are all important notes for safety and must be followed in addition to International standards (ISO/IEC) *1) and other safety regulations.

- *1) ISO 4414: Pneumatic fluid power -- General rules relating to systems.
- ISO 4413: Hydraulic fluid power -- General rules relating to systems.
- IEC 60204-1: Safety of machinery -- Electrical equipment of machines. (Part 1: General requirements)
- ISO 10218-1992: Manipulating industrial robots -Safety.
- etc.

 Caution :	CAUTION indicates a hazard with a low level of risk which, if not avoided, could result in minor or moderate injury.
 Warning :	WARNING indicates a hazard with a medium level of risk which, if not avoided, could result in death or serious injury.
 Danger :	DANGER indicates a hazard with a high level of risk which, if not avoided, will result in death or serious injury.

Warning

1. The compatibility of the product is the responsibility of the person who designs the equipment or decides its specifications.

Since the product specified here is used under various operating conditions, its compatibility with specific equipment must be decided by the person who designs the equipment or decides its specifications based on necessary analysis and test results. The expected performance and safety assurance of the equipment will be the responsibility of the person who has determined its compatibility with the product. This person should also continuously review all specifications of the product referring to its latest catalogue information, with a view to giving due consideration to any possibility of equipment failure when configuring the equipment.

2. Only personnel with appropriate training should operate machinery and equipment.

The product specified here may become unsafe if handled incorrectly. The assembly, operation and maintenance of machines or equipment including our products must be performed by an operator who is appropriately trained and experienced.

3. Do not service or attempt to remove product and machinery/equipment until safety is confirmed.

1. The inspection and maintenance of machinery/equipment should only be performed after measures to prevent falling or runaway of the driven objects have been confirmed.
2. When the product is to be removed, confirm that the safety measures as mentioned above are implemented and the power from any appropriate source is cut, and read and understand the specific product precautions of all relevant products carefully.
3. Before machinery/equipment is restarted, take measures to prevent unexpected operation and malfunction.

4. Contact SMC beforehand and take special consideration of safety measures if the product is to be used in any of the following conditions.

1. Conditions and environments outside of the given specifications, or use outdoors or in a place exposed to direct sunlight.
2. Installation on equipment in conjunction with atomic energy, railways, air navigation, space, shipping, vehicles, military, medical treatment, combustion and recreation, or equipment in contact with food and beverages, emergency stop circuits, clutch and brake circuits in press applications, safety equipment or other applications unsuitable for the standard specifications described in the product catalogue.
3. An application which could have negative effects on people, property, or animals requiring special safety analysis.
4. Use in an interlock circuit, which requires the provision of double interlock for possible failure by using a mechanical protective function, and periodical checks to confirm proper operation.

Caution

The product is provided for use in manufacturing industries.

The product herein described is basically provided for peaceful use in manufacturing industries. If considering using the product in other industries, consult SMC beforehand and exchange specifications or a contract if necessary.
If anything is unclear, contact your nearest sales branch.

Limited warranty and Disclaimer/Compliance Requirements

The product used is subject to the following "Limited warranty and Disclaimer" and "Compliance Requirements".

Read and accept them before using the product.

Limited warranty and Disclaimer

1. The warranty period of the product is 1 year in service or 1.5 years after the product is delivered, whichever is first. *2)
Also, the product may have specified durability, running distance or replacement parts. Please consult your nearest sales branch.
2. For any failure or damage reported within the warranty period which is clearly our responsibility, a replacement product or necessary parts will be provided.
This limited warranty applies only to our product independently, and not to any other damage incurred due to the failure of the product.
3. Prior to using SMC products, please read and understand the warranty terms and disclaimers noted in the specified catalogue for the particular products.

*2) Vacuum pads are excluded from this 1 year warranty.

A vacuum pad is a consumable part, so it is warranted for a year after it is delivered.

Also, even within the warranty period, the wear of a product due to the use of the vacuum pad or failure due to the deterioration of rubber material are not covered by the limited warranty.

Compliance Requirements

1. The use of SMC products with production equipment for the manufacture of weapons of mass destruction (WMD) or any other weapon is strictly prohibited.
2. The exports of SMC products or technology from one country to another are governed by the relevant security laws and regulation of the countries involved in the transaction. Prior to the shipment of a SMC product to another country, assure that all local rules governing that export are known and followed.

Operator

- ◆ This operation manual is intended for those who have knowledge of machinery using pneumatic equipment, and have sufficient knowledge of assembly, operation and maintenance of such equipment. Only those persons are allowed to perform assembly, operation and maintenance.
- ◆ Read and understand this operation manual carefully before assembling, operating or providing maintenance to the product.

■ Safety Instructions

Warning

- Do not disassemble, modify (including changing the printed circuit board) or repair.
An injury or failure can result.
- Do not operate the product outside of the specifications.
Do not use for flammable or harmful fluids.
Fire, malfunction, or damage to the product can result.
Verify the specifications before use.
- Do not operate in an atmosphere containing flammable or explosive gases.
Fire or an explosion can result.
This product is not designed to be explosion proof.
- If using the product in an interlocking circuit:
 - Provide a double interlocking system, for example a mechanical system.
 - Check the product regularly for proper operation.Otherwise malfunction can result, causing an accident.
- The following instructions must be followed during maintenance:
 - Turn off the power supply.
 - Stop the air supply, exhaust the residual pressure and verify that the air is released before performing maintenance.Otherwise an injury can result.

Caution

- Do not touch terminals and printed circuit board inside the product.
Otherwise it can cause electric shock, malfunction or damage to the product can result.
- After maintenance is complete, perform appropriate functional inspections.
Stop operation if the equipment does not function properly.
Safety cannot be assured in the case of unexpected malfunction.

■NOTE

- Follow the instructions given below when designing, selecting and handling the product.
 - The instructions on design and selection (installation, wiring, environment, adjustment, operation, maintenance, etc.) described below must also be followed.
 - ◆ Product specifications
 - Use the specified voltage.
Otherwise failure or malfunction can result.
 - Do not place two or more actuators close together.
When using two or more actuators closely in parallel, keep a distance of at least 40 mm between the actuator tubes to prevent magnetic interference from affecting the product, which can cause malfunction.
(If the distance is specified for the actuator, use that value.)
 - Detection by an Auto switch mounted in a mid-stroke position depends on the piston speed. Conditions must satisfy the equation below.

Wherein;

Maximum detectable piston speed = V [mm/s]

$$V \text{ [mm/s]} = \frac{\text{Operating range of Auto switch [mm]}}{\text{Operating time of load [ms]}} \times 1000$$

- Design the product to prevent reverse current when the circuit is opened or the product is forced to operate for operational check.
Reverse current can cause malfunction or damage to the product.
- Reserve a space for maintenance.
Allow sufficient space for maintenance when designing the system.

■Product handling

◆ Installation

- Tighten to the specified tightening torque. (0.05 to 0.15 Nm)
If the tightening torque is exceeded the mounting screws and brackets may be broken. If the tightening torque is insufficient, the product can be displaced.
(Refer to "Mounting and Installation" on page 11.)
- Be sure to ground terminal FG when using a commercially available switch-mode power supply.
- Never mount an actuator equipped with Auto switch in a location that will be used as a foothold.
The product may be damaged if excessive force is applied by stepping or climbing onto it.
- Do not drop, hit or apply excessive shock (over 1000 m/s²) to the Auto switch.
Otherwise damage to the internal parts can result, causing malfunction.

◆ Wiring

- Do not pull hard on the lead wire. In particular, never lift an Auto switch actuator by holding the lead wires.
Otherwise damage to the internal parts can result, causing malfunction.
- Avoid repeatedly bending or stretching the lead wire, or placing heavy load on them.
Repetitive bending stress or tensile stress can cause the sheath of the wire to peel off, or breakage of the wire.
If the lead wire can move, fix it near the body of the product.
The recommended bend radius is 40 to 80 mm. Contact SMC for details.
- Wire correctly.
Incorrect wiring can break the product.
- Do not perform wiring while the power is on.
Otherwise damage to the internal parts can result, causing malfunction.
- Do not route wires and cables together with power or high voltage cables.
Otherwise the product can malfunction due to interference of noise and surge voltage from power and high voltage cables to the signal line. Route the wires (piping) of the product separately from power or high voltage cables.
- Confirm proper insulation of wiring.
Poor insulation (interference from another circuit, poor insulation between terminals, etc.) can lead to excess voltage or current being applied to the product, causing damage.

- Design the system to prevent reverse current when the product is forced to operate for operational check.
Depending on the circuit used, insulation may not be maintained when operation is forced, allowing reverse current to flow, which can cause malfunction and damage the product.
- Keep wiring as short as possible to prevent interference from electromagnetic noise and surge voltage.
Do not use a cable longer than 100 m.
- Strip the cable sheath in the correct direction.
Otherwise the insulation material can be torn or damaged.



◆Environment

- Do not use the product in a place where strong magnetic field exists.
Otherwise malfunction of the product or demagnetization of the internal magnet can result.
- Do not use the product in an atmosphere with accumulation of iron waste or close contact with magnetic substances.
When a large amount of iron waste such as machining chips or spatter has accumulated, or a magnetic substance (something attracted by a magnet) is brought into close proximity with the actuator, it may cause the Auto switch to malfunction due to weakening.
- Do not use the product in an environment that is constantly exposed to the splash of water.
This can cause insulation failure or malfunction due to swelling of the potting resin.
- Do not use in a place where the product could be splashed by oil or chemicals.
If the product is to be used in an environment containing oils or chemicals such as coolant or cleaning solvent, even for a short time, it may be adversely affected. (insulation failure, malfunction due to swelling of the potting resin, or hardening of the potting resin, or hardening of the lead wires)
- Do not use the product in an environment where corrosive gases or fluids could be splashed.
Otherwise damage to the product and malfunction can result.
- Do not use in an area where surges are generated.
If there is equipment which generates a large amount of surge (solenoid type lifter, high frequency induction furnace, motor, etc.) close to the actuator, this may cause deterioration or breakage of the internal circuit of the Auto switch. Avoid sources of surge generation and crossed lines.
- Do not use a load which generates surge voltage.
When a surge-generating load such as a relay or solenoid is driven directly, use an Auto switch with a built-in surge absorbing element.
- The product is CE marked, but not immune to lightning strikes. Take measures against lightning strikes in the system.
- Mount the product in a place that is not exposed to vibration or impact (over 1000 m/s²).
Otherwise failure or malfunction can result.
- Do not use the product in an environment that is exposed to temperature cycle.
Heat cycles other than ordinary changes in temperature can adversely affect the inside of the product.
- Do not expose the product to direct sunlight.
If using in a location directly exposed to sunlight, shade the product from the sunlight. Otherwise failure or malfunction can result.
- Keep within the specified ambient temperature range.
Otherwise malfunction can result.
- Do not operate close to a heat source, or in a location exposed to radiant heat.
Otherwise malfunction can result.

◆ Adjustment and Operation

- Adjust the Auto switch in the middle of the operating range and then fix it.

Adjust the position of the Auto switch so that the piston stops in the middle of the operating area (where Auto switch is in ON status).

Mounting the Auto switch close to the edge of the operating range can cause operation to be unstable.

Air grippers and rotary actuators have their own setting method. Follow their instructions.

- Turn the power on after connecting a load.

If switched on with no load, excess current may flow, causing the product to break instantly.

◆ Maintenance

- Turn off the power supply, stop the supplied air, exhaust the residual pressure and verify the release of air before performing maintenance.

There is a risk of unexpected malfunction.

- Perform regular maintenance and inspections.

There is a risk of unexpected malfunction.

- Do not touch the terminals while the power is on.

Otherwise malfunction and damage to the product can result.

- Do not use solvents such as benzene, thinner etc. to clean the Auto switch.

They could damage the surface of the body and erase the markings on the body.

Use a soft cloth to remove stains.

For heavy stains, use a cloth soaked with diluted neutral detergent and fully squeezed, then wipe up the stains again with a dry cloth.

◆ Other

- Contact SMC for information regarding water resistance, lead wire bend resistance.

- Contact SMC if there is a problem with the product's ON/OFF positions (hysteresis).

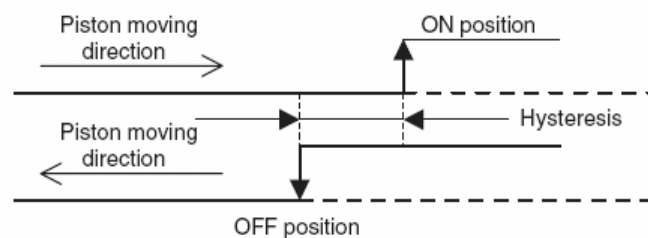

Model Indication and How to Order

D-M9

• Output type

Symbol	Specification
N	3-wire, NPN
P	3-wire, PNP
B	2-wire

• Electric entry

Symbol	Specification
NIL	In line
V	Perpendicular

• Lead wire length

Symbol	Specification
NIL	500 mm (Half strip)
M	1000 mm (Half strip)
L	3000 mm (Half strip)
Z	5000 mm (Half strip)
SAPC	500 mm (M8 3 pin pre-wired)
SBPC	500 mm (M8 4 pin pre-wired)
SDPC	500 mm (M12 4 pin pre-wired)
MAPC	1000 mm (M8 3 pin pre-wired)
MBPC	1000 mm (M8 4 pin pre-wired)
MDPC	1000 mm (M12 4 pin pre-wired)

Summary of Product parts

- Summary of Product parts
D-M9B/M9N/M9P

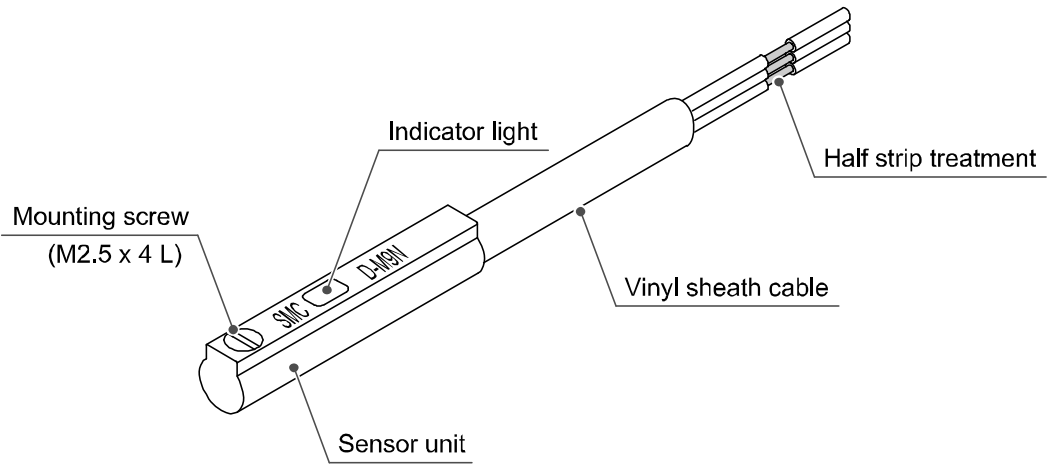

D-M9BV/M9NV/M9PV

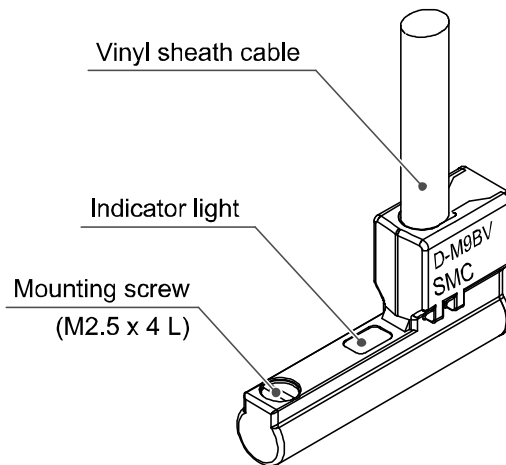

■ Definition and terminology

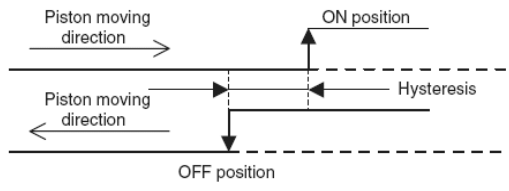
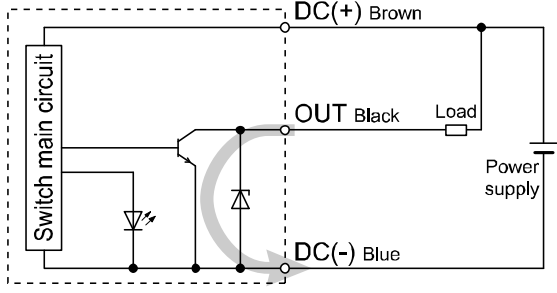
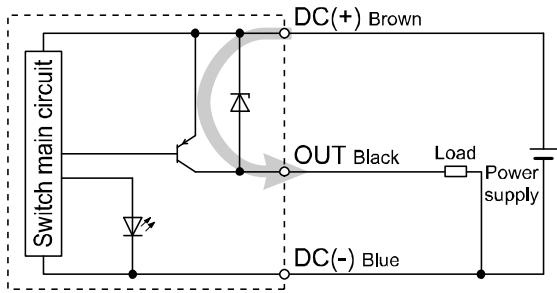
	Term	Meaning and definition
2	2-wire Auto switch	Auto switch which has only signal line and COM line.
C	Current leakage	The current flowing to the load when the Auto switch turns off.
H	Hysteresis	The difference between the points when the Auto switch turns on and off, which is provided to prevent chattering. 
I	Internal voltage drop	The voltage applied between the COM and signal line when the Auto switch turns on.
L	Load current	The current flowing to the load when the Auto switch turns on.
M	Most sensitive position	The center position of the sensor unit (which gets the strongest reaction of the sensor unit), which means the center position of an operating range as well.
N	NPN output	Auto switch which sinks current from the signal line when turning on. 
P	PNP output	Auto switch which sources current from the signal line when turning on. 
R	Reed Auto switch	Auto switch which generates on and off outputs with a mechanical contact.
S	Sequence controller (PLC)	The device to perform sequence control, which performs controlling such as receipt of inputs from the Auto switch along with programming and sending of the output to other machines.
	Solid state Auto switch	Auto switch which generates on and off outputs with or without mechanical contact such as a transistor.

Mounting and Installation

■ Installation

When mounting the Auto switch to the actuator, the appropriate mounting bracket should be used.

"How to mount" depends on the actuator type and bore size.

Please refer to the actuator catalogue.

For new Auto switch applications, confirm that the actuator includes a magnet before assembling the Auto switch and bracket.

• Tightening torque

Use a watchmaker driver whose grip diameter is 5 to 6 mm when tightening the mounting screw.

M2.5 mount screw tightening torque shall be 0.05 to 0.15 Nm (0.5 to 1.5 kgf•cm)

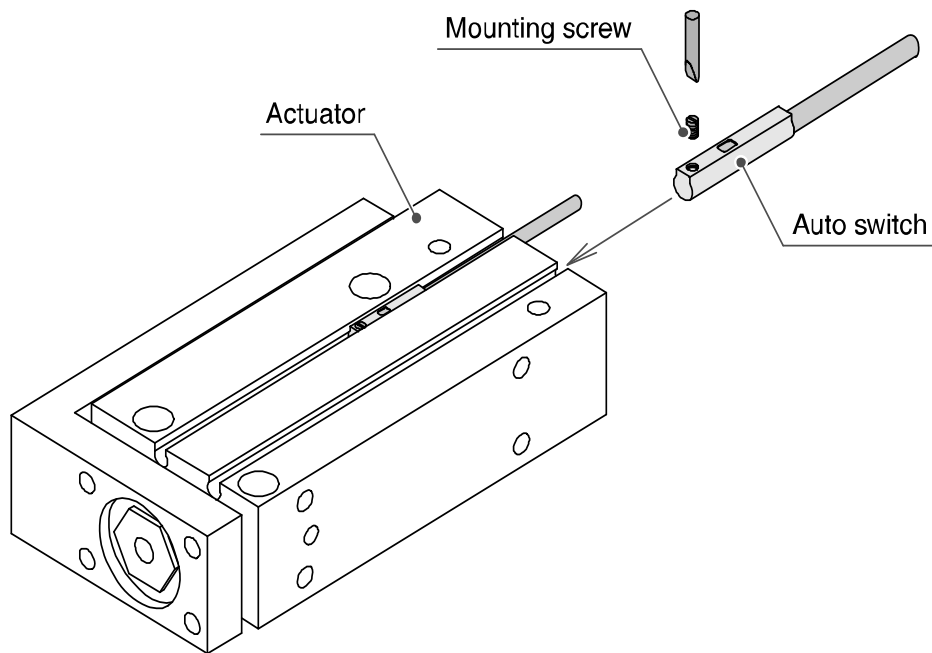

• Setting the detection position

Position the actuator at the end of the stroke.

Set the Auto switch in the position where the Auto switch Red light is ON.

(Detecting actuator end)

Based on A and B dimensions in the actuator catalogue, set the Auto switch position.

During installation, perform adjustment while checking the operating conditions of the Auto switch.

Air grippers and rotary actuators have their own setting method.

Follow the instructions in the relevant manual.

•Internal circuit
D-M9N(V)

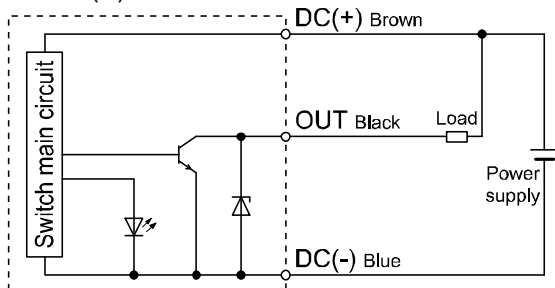

D-M9P(V)

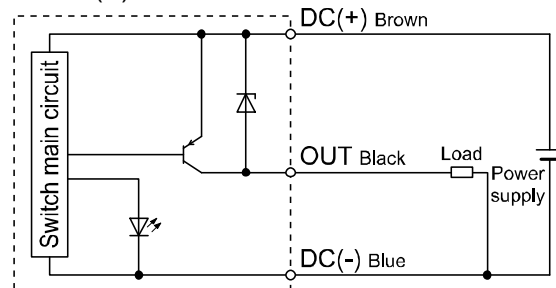

D-M9B(V) (Sink input mode)

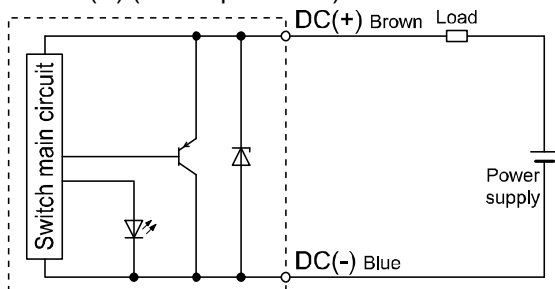

D-M9B(V) (Source input mode)

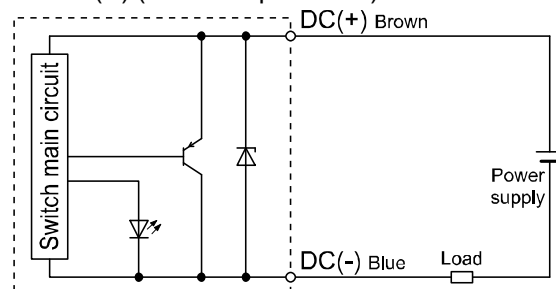

*: The number marked on each lead wire color shows the pin number of pre-wired connector.

Maintenance

After the power has been disconnected, please observe the following precautions:-

Regarding the actuator operation set up, the contents of the program may be maintained by the customer's application system.

Take care to confirm safety when the power is re-connected, and the actuator operation is resumed, because the operation may have stopped in an unstable condition.

Troubleshooting

When the Auto switch falls in operation failure, identify the trouble with the following flow chart. A failure of the Auto switch might depend on operating environment (application etc.) and needs to be given a measure by contacting to us separately.

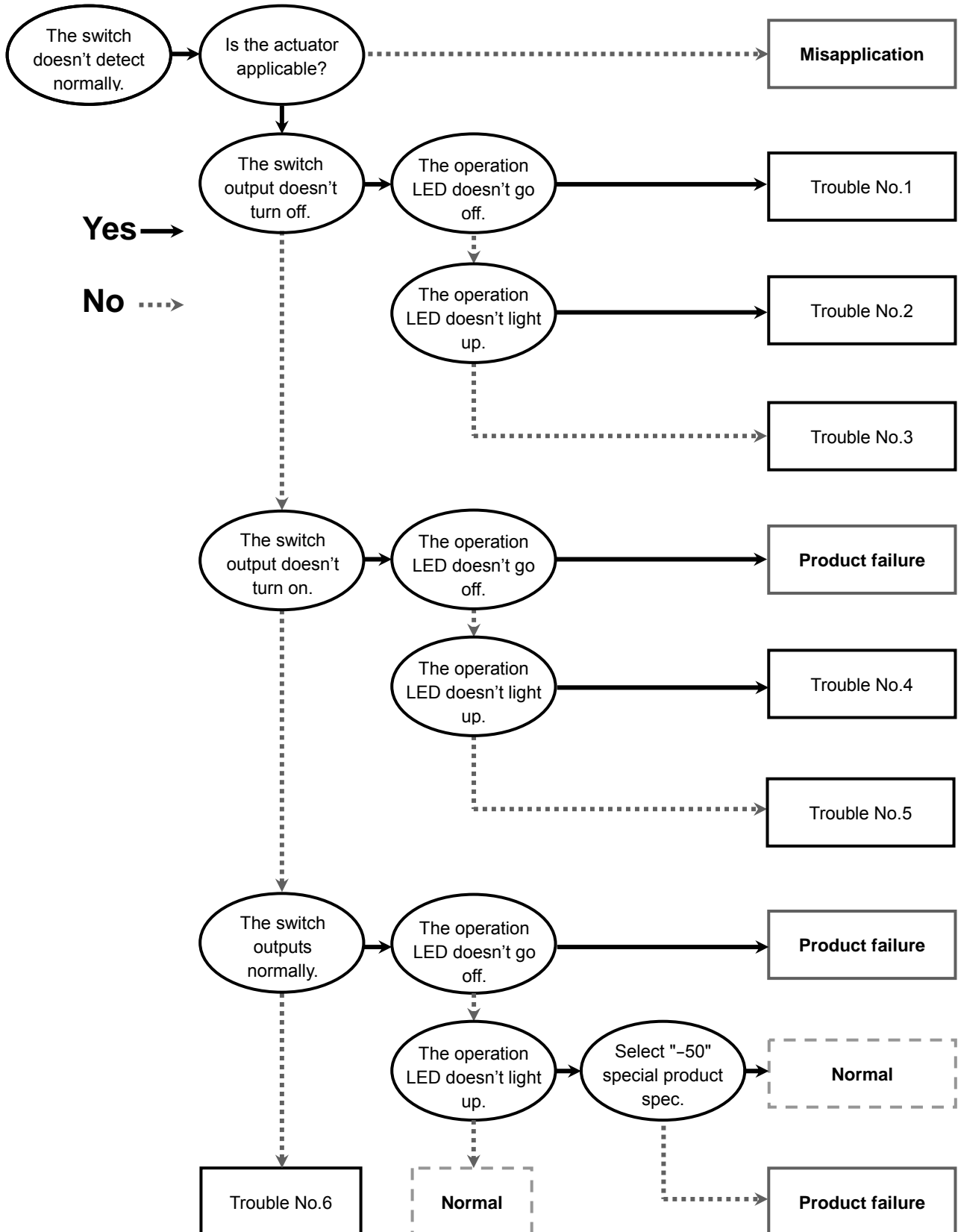

•Trouble list

Trouble No.	Trouble	Possible cause	Investigation to find possible cause	Countermeasure
1	The switch output doesn't turn off. The operation LED doesn't go off.	Malfunction due to disturbance magnetic field	The effect of magnetic field generated by adjacent actuator	Place a magnetic shield plate to the actuator.
		Improper setting (mounting) position *Narrow angle	The presence of the following conditions Switch operating range >Actuator operating stroke	Displace the Auto switch set position from the center of the actuator operating range.
2	The switch output doesn't turn off. The operation LED doesn't light up.	Incorrect wiring (2-wire)	Reverse connection of wiring (brown and blue)	Correct wiring. (Refer to "Internal circuit" on page 12.)
		Product failure (3-wire)		Replace the product.
3	The switch output doesn't turn off. The operation LED operates properly.	Mismatch the load current specification (2-wire)	Satisfaction of the following relations by the load current specification Load voltage is "ON" level > (Current leakage x n) x load resistance or Load current is "OFF" level > (Current leakage x n) n: The number of parallel connecting switches	Select 3-wire Auto switch or reed Auto switch. Reduce the number of switches.
		Incorrect wiring (3-wire)	Reverse connection of wiring (black and blue)	Correct wiring. (Refer to "Internal circuit" on page 12.)

Trouble No.	Trouble	Possible cause	Investigation to find possible cause	Countermeasure
4	The switch output doesn't turn on. The operation LED doesn't light up.	Power supply failure	Power supply voltage (zero or extremely low)	Adjust power supply voltage to a given value. (Refer to "Power supply voltage or Load voltage" in Specifications on page 17.)
		Incorrect wiring	Voltage (load) applied to the Auto switch	Correct wiring. (Refer to "Internal circuit" on page 12.)
		Improper setting (mounting) position	Detection close to the limit of operating range	Move the Auto switch to proper position (near the center of the switch operating angle).
		Displacement from set position	Looseness of the switch unit or switch mounting screw	Fix to proper position at appropriate torque. (Tightening torque: 0.05 to 0.15 Nm)
		Displacement of the actuator stopping angle	Deviation of the actuator stopping angle (position)	Stabilize stop position.
		Lowering of magnetic force for detection (demagnetization)	The presence of magnetic filed source near the actuator (electric welding machine conductor and strong magnet, etc.)	Place a magnetic shield plate between magnetic filed source and the actuator.
			The effect of magnetic field generated by adjacent actuator (placed within 20 mm)	Separate the actuator (by 40 mm or more). Place a magnetic shield plate.
			The presence of deposit of magnetic material (cutting chip) on the actuator	Remove the magnetic deposit.
Breakage of lead wire	The presence of repeated bending stress to a part of lead wire (bending radius, tensile force to the lead wire)	Correct wiring. (Adjust tensile force and enlarge bending radius.)		

Trouble No.	Trouble	Possible cause	Investigation to find possible cause	Countermeasure
5	The switch output doesn't turn on. The operation LED operates properly.	Mismatch the load current specification (2-wire)	Satisfaction of the following relations by the load current specification Load voltage is "ON" level > Load voltage - (Internal voltage drop x n) n: The number of series connecting switches	Select 3-wire Auto switch or reed Auto switch. Reduce the number of switches.
		Incorrect wiring (output line) (3-wire)	Condition of connected part (connector contact pin and crimping terminal)	Correct wiring. (Perform wiring of connected part again.)
		Breakage of lead wire (black) (3-wire)	The presence of repeated bending stress to a part of lead wire (bending radius, tensile force to the lead wire)	Correct wiring. (Adjust tensile force and enlarge bending radius.)
6	The operation is unstable. (chattering)	Improper setting (mounting) position	Detection close to the limit of switch operating angle	Move the switch to proper position (near the center of the switch operating angle).
		Displacement from set position	Looseness of the switch unit or switch mounting screw	Fix to proper position at appropriate torque. (Tightening torque: 0.05 to 0.15 Nm)
		Incorrect wiring	Condition of connected part (connector contact pin and crimping terminal)	Correct wiring. (Perform wiring of connected part again.)
		Breakage of lead wire	The presence of repeated bending stress to a part of lead wire (bending radius, tensile force to the lead wire)	Correct wiring. (Adjust tensile force and enlarge bending radius.)
		Malfunction due to disturbance magnetic field	The presence of magnetic field source near the actuator (cylinder, electric welding machine conductor, motor, magnet etc.)	Place a magnetic shield plate between magnetic field source and the actuator, or separate magnetic field source from the actuator.
	The switch operates at multiple points.	Malfunction due to disturbance magnetic field	The effect of magnetic field generated by adjacent actuator	Place a magnetic shield plate to the actuator.
The load doesn't work.	Operating angle range Detection at intermediate position	Satisfaction of the following relations by the actuator rotation speed Load operating time [s] < Auto switch operating range [mm] / Actuation operating speed [mm/s]	Decrease the actuating driving speed until specified relations can be satisfied.	

Specifications

■ Specification

Switch part no.	D-M9N	D-M9NV	D-M9P	D-M9PV	D-M9B	D-M9BV
Wiring	3-wire				2-wire	
Output	NPN		PNP		-	
Lead wire orientation	In line	Perpendicular	In line	Perpendicular	In line	Perpendicular
Applicable load	IC circuit/Relay/PLC				24 VDC Relay/PLC	
Power supply voltage	5/12/24 VDC (4.5 to 28 VDC)				-	
Current consumption	10 mA or less				-	
Load voltage	28 VDC or less		-		24 VDC (10 to 28 VDC)	
Load current	40 mA or less				2.5 to 40 mA	
Internal voltage drop	0.8 V or less at load current of 10 mA (2 V or less at load current of 40 mA)				4 V or less	
Current leakage	100 μ A or less at 24 VDC				0.8 mA or less	
Operating time	1 ms or less					
Indication light	Operating position: The Red LED lights up.					
Electrical entry	Grommet					
Lead wire	Vinyl sheath cable 2.7 x 3.2 oval, 0.15 mm ² , 2-wire (D-M9B(V)), 3-wire (D-M9N(V),D-M9P(V))					
Impact proof	1000 m/s ²					
Insulation resistance	50 M Ω or more under the test voltage 500 VDC (between case and cable)					
Withstand voltage	1000 VAC 1 min. (between case and cable)					
Ambient temperature	-10 to 60 °C					
Enclosure	IEC 60529 criteria IP67, JISC0920 watertight construction					

■ Dimensions
D-M9B/N/P

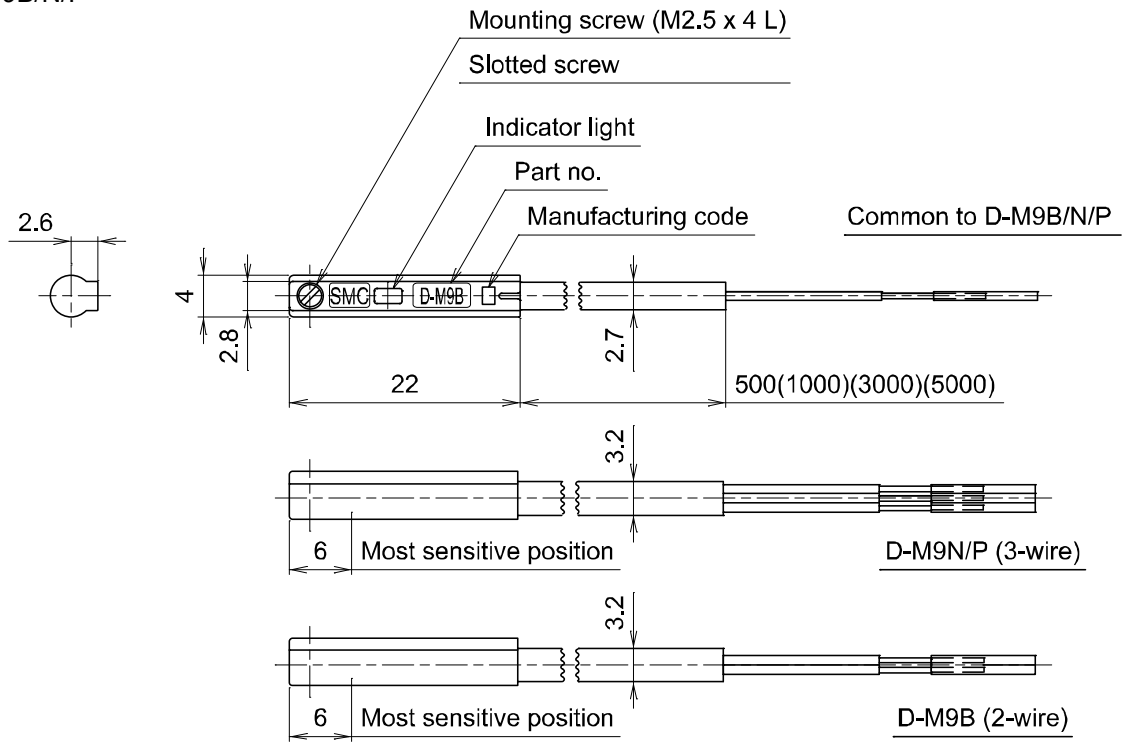

D-M9BV/NV/PV

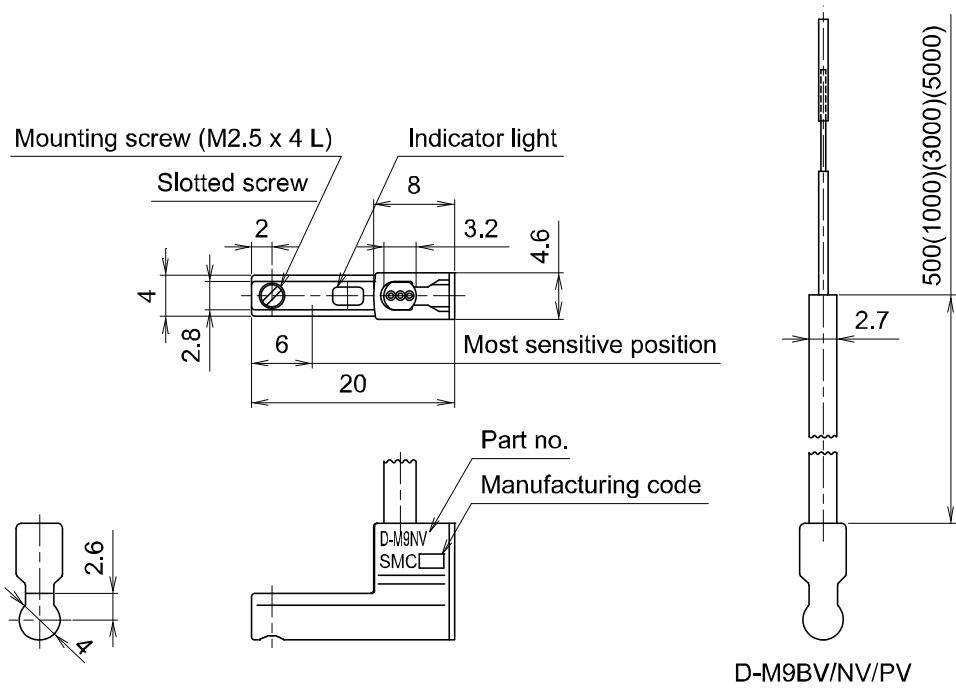

•Operating range

Air cylinder

*: The table below shows the operating range of the direct-mounted Auto switch on the round groove.

Please contact us if a mounting bracket is used.

Unit: [mm]

Bore size Series	4	6	8	10	12	15	16	20	25	32	40	50	63	80	100	125	160
CU	-	3	-	4	-	-	5.5	7	7	7.5	-	-	-	-	-	-	-
CQS	-	-	-	-	3	-	4	5.5	5.5	-	-	-	-	-	-	-	-
CQ2	-	-	-	-	-	-	-	-	-	6	6	7	7.5	8	8.5	-	-
RQ	-	-	-	-	-	-	-	5.5	6	6	6	7	9.5	10	11	-	-
MXH	-	3	-	3.5	-	-	5	6	-	-	-	-	-	-	-	-	-
MXU	-	3	-	3.5	-	-	4.5	-	-	-	-	-	-	-	-	-	-
MXS	-	3	3	-	3	-	4.5	5	5.5	-	-	-	-	-	-	-	-
MXQ	-	3	3	-	3.5	-	4.5	4.5	5.5	-	-	-	-	-	-	-	-
MXF	-	-	3	-	3	-	4.5	5	-	-	-	-	-	-	-	-	-
MXW	-	-	3.5	-	3.5	-	5	6	5.5	-	-	-	-	-	-	-	-
MXP	-	3	3	3.5	3	-	3	-	-	-	-	-	-	-	-	-	-
MY1B	-	-	-	4	-	-	4.5	5.5	-	-	-	-	-	-	-	-	-
MY1M	-	-	-	-	-	-	9	8.5	-	-	-	-	-	-	-	-	-
MY1C	-	-	-	-	-	-	7.5	7.5	-	-	-	-	-	-	-	-	-
MY1H	-	-	-	3.5	-	-	4.5	5.5	-	-	-	-	-	-	-	-	-
MY1*W	-	-	-	-	-	-	8	8	-	-	-	-	-	-	-	-	-
CXT	-	-	-	-	3	-	4	5.5	5.5	6	6	-	-	-	-	-	-
CLQ	-	-	-	-	3	-	4	4.5	4.5	5	5.5	6	6.5	7	7.5	-	-
REBR	-	-	-	-	-	4.5	-	-	-	-	-	-	-	-	-	-	-
MK	-	-	-	-	3	-	4	-	-	6.5	5.5	6.5	6.5	-	-	-	-
MK2	-	-	-	-	-	-	-	-	-	6.5	5.5	6.5	6.5	-	-	-	-
RSQ	-	-	-	-	3	-	-	-	-	6	6	7	-	-	-	-	-
CEP1	-	-	-	-	3	-	-	4	-	-	-	-	-	-	-	-	-
CE1	-	-	-	-	-	-	-	-	-	6	6	6	7	-	-	-	-

*1: It is not for guarantee but measure including hysteresis. (Dispersion is approx. ±30%)

It might be changed drastically depending on the ambient.

Air cylinder (continued)

Unit: [mm]

Bore size Series	4	6	8	10	12	15	16	20	25	32	40	50	63	80	100	200
MY2H	-	-	-	-	-	-	6	-	9	-	8.5	-	-	-	-	-
MY2HT	-	-	-	-	-	-	5	-	9.5	-	8	-	-	-	-	-
MY2C	-	-	-	-	-	-	4	-	4.5	-	5	-	-	-	-	-
CY3R	-	4.5	-	6.5	-	4.5	-	5	-	-	-	-	-	-	-	-
CXSJ	-	2.5	-	3	-	3.5	-	4.5	4.5	5	-	-	-	-	-	-
MIS	-	-	3	-	3.5	-	-	4.5	5.5	7	-	-	-	-	-	-
MIW	-	-	3	-	2.5	-	-	4	5.5	7	-	-	-	-	-	-
RZQ	-	-	-	-	-	-	-	-	-	6	5.5	6	6.5	-	-	-
MY3	-	-	-	-	-	-	4	-	6	-	8.5	-	8.5	-	-	-
MXY	-	3.5	3.5	-	3.5	-	-	-	-	-	-	-	-	-	-	-
MXJ	2.5	2.5	2.5	-	-	-	-	-	-	-	-	-	-	-	-	-
CY1R	-	5	-	6.5	-	4.5	-	5.5	-	-	-	-	-	-	-	-
CUJ	-	3	3.5	3.5	-	-	-	-	-	-	-	-	-	-	-	-
CY1F	-	-	-	5.5	-	6	-	-	6	-	-	-	-	-	-	-
ZCUK	-	-	-	4	-	-	5	7	7	7	-	-	-	-	-	-
RLQ	-	-	-	-	-	-	-	-	-	5.5	5	5.5	7	-	-	-
XL	-	-	-	-	-	-	4.5	-	4.5	-	5.5	6.5	7	8	9	9
XM	-	-	-	-	-	-	4.5	-	4.5	-	5.5	6.5	7	8	9	9
XY	-	-	-	-	-	-	4.5	-	4.5	-	5.5	6.5	7	8	9	9

*1: It is not for guarantee but measure including hysteresis. (Dispersion is approx. ±30%)

It might be changed drastically depending on the ambient.

Electric actuator

Unit: [mm]

Bore size Series	Operating range
LXF*	4
LXPB*B	3
LXPB*S	3.5
LXS*	3
LZB*3	2.5
LZB*5	4.5
LZC*3	3
LZC*5	3

*1: It is not for guarantee but measure including hysteresis. (Dispersion is approx. $\pm 30\%$)
It might be changed drastically depending on the ambient.

Air gripper

Unit: Hysteresis [mm]

Bore size Series	6	8	10	12	15	16	20	25	30	32	40	50	63	80
MHZ2	-	-	0.5	-	-	0.5	0.8	-	-	0.5	0.5	-	-	-
MHR2	-	-	0.5	-	0.5	-	0.5	-	0.5	-	-	-	-	-
MHR3	-	-	0.5	-	0.5	-	-	-	-	-	-	-	-	-
MHK2	-	-	-	0.3	-	0.5	0.5	0.5	-	-	-	-	-	-
MHS2	-	-	-	-	-	0.5	0.5	0.5	-	-	-	-	-	-
MHS*3	-	-	-	-	-	0.5	0.5	0.5	-	0.6	0.6	0.6	0.6	0.6
MHS4	-	-	-	-	-	0.5	0.5	0.5	-	-	-	-	-	-
MHT2	-	-	-	-	-	-	-	-	-	3	3	3	3	-
MHC2	-	-	0.5	-	-	-	-	-	-	-	-	-	-	-
MHF2	-	0.5	-	0.5	-	0.5	0.8	-	-	-	-	-	-	-

Unit: Angle [°]

Bore size Series	6	8	10	12	15	16	20	25	30	32	40	50	63	80
MHY2	-	-	2	-	-	2	2	2	-	-	-	-	-	-
	-	-	4	-	-	4	3	3	-	-	-	-	-	-

*1: It is not for guarantee but measure including hysteresis. (Dispersion is approx. $\pm 30\%$)
It might be changed drastically depending on the ambient.

Rotary actuator/Gripper

Unit: Angle [°]

Bore size Series	0.5	1	2	3	7	10	15	16	20	25	30	40	50	70	100	200
CRQ2	-	-	-	-	-	61	47	-	40	-	29	24	-	-	-	-
MSQ	-	49	50	47	31	42	-	-	35	-	30	-	24	22	19	14
CRJ	45	40	-	-	-	-	-	-	-	-	-	-	-	-	-	-

Unit: Hysteresis [mm]

Bore size Series	0.5	1	2	3	7	10	15	16	20	25	30	40	50	70	100	200
MRHQ	-	-	-	-	-	0.5	-	0.6	0.5	0.6	-	-	-	-	-	-

*1: It is not for guarantee but measure including hysteresis. (Dispersion is approx. ±30%)

It might be changed drastically depending on the ambient.

*2: Please contact SMC sales division regarding another models.

Revision history

- A: Add the D-M9*V series and the applicable Actuator.
- B: Add the applicable Actuator.
Change the torque range for mounting switch.
Change the product spec.
- C: Modify the contents.
- D: Modify the contents.
- E: Limited warranty and Disclaimer are added.

SMC Corporation

URL <http://www.smcworld.com>

4-14-1, Sotokanda, Chiyoda-ku, Tokyo 102-0021 Japan
Tel:+81 3 5207 8249 Fax:+81 3 5298 5362

Note: Specifications are subject to change without prior notice and any obligation on the part of the manufacturer.
© 2008-2013 SMC Corporation All Rights Reserved



No.D-※S-OMG0002-E